



# ExCos-D Transducer for ExPro sensors (probes) ExPro-... Temperature-/humidity sensors (°C, % rH)

Electrical, explosionproof transducer only connectable for **ExPro-...** temperature and humidity sensors.

24 VAC/DC supply, 0...10 V / (0) 4...20 mA output

PTB-certified in acc. with ATEX directive EC/94/9 for zone 1, 2, 21, 22.

Type of transducer:
<b>ExCos - D</b>
<b>ExCos - D - A</b>
Type of sensor (probe):
<b>ExPro - CT...</b>
<b>ExPro - CF...</b>
<b>ExPro - CTF...</b>

## Transducer

Type	supply	installation area	connectable sensors	function of sensors	sensor connection	wiring
<b>ExCos - D</b>	24 VAC/DC	zone 1, 2, 21, 22	ExPro -T ..., ExPro - F..., ExPro - TF...	°C, %rH, combination °C/%rH	via plug - and - socket connection	SB 2.0
<b>ExCos - D... - A</b>	as above, but with additional intrinsically safe analogue output to connect an external digital indicator(0) 4 .. 20 mA (Exi)					SB 3.0

## Connectable sensors (compulsory for ExCos-... transducer) – have a look onseparate data sheet

Type	function	measuring range	length of sensor	connectable to	installation sensor	installation transducer
<b>ExPro - CT...</b>	temperature	-40...+125 °C	50/100/150/200 mm	ExCos-D..., RedCos-D...	zone 1, 2, 21, 22	zone 1, 2, 21, 22 (ExCos...)
<b>ExPro - CF...</b>	humidity	0...100 % rH	50/100/150/200 mm	ExCos-D..., RedCos-D...	zone 1, 2, 21, 22	zone 1, 2, 21, 22 (ExCos...)
<b>ExPro - CTF...</b>	combination temp./humidity	-40...+125 °C/0...100 % rH	50/100/150/200 mm	ExCos-D..., RedCos-D...	zone 1, 2, 21, 22	zone 1, 2, 21, 22 (ExCos...)

## Application

### ExCos-D... transducer



### ExPro... sensor



### Example: room sensor



### Example: duct sensor



## Description

The new **ExCos-D...** transducer generation from together with direct coupled **ExPro sensors** are a revolution for measuring temperature and/or humidity in HVAC systems, in chemical, pharmaceutical, industrial and Offshore-/Onshore plants, for use in hazardous areas zone 1, 2 (gas) and zone 21, 22 (dust).

Highest protection class (ATEX) and IP 66 protection, small dimension, universal functions and technical data guarantee safe operation even under difficult environmental conditions.

The measuring ranges are scalable within the maximum ranges. The analogue output signal is either 0...10 VDC or 4...20 mA and can be selected on site. The integrated display is for actual value indication which can be switched off.

All sensors are programmable on site without any additional tools.

**ExCos-D-A** transducer are additionally equipped with a 4...20 mA IS (IS = intrinsically safe) output, e.g. for an external indicator.

## Highlights transducer

- ▶ For all type of gas, mixtures, vapours and dust for use in zone 1, 2, 21 and 22
- ▶ No additional Ex-i module required
- ▶ No intrinsically safe wiring/installation between panel and sensor required
- ▶ No intrinsically safe wiring/installation and no space in the panel required
- ▶ Integrated Ex-e junction box
- ▶ Power supply 24 VAC/DC
- ▶ Display with backlight, can be switched off
- ▶ Scalable analogue output, selectable 0...10 V / (0) 4...20 mA
- ▶ Compact design and small dimension (L x W x H = 177 x 107 x 66 mm)
- ▶ Robust aluminium housing in protection class IP 66
- ▶ Down to -20°C ambient temperature applicable
- ▶ Password locking
- ▶ Optional IS-output (4...20 mA) for external indicator in Ex-areas

## Highlights sensor

- ▶ For all type of gas, mixtures, vapours and dust for use in zone 1, 2, 21 and 22
- ▶ Plug-and-socket connection to ExCos-D... transducer, removable
- ▶ The ExPro probe appropriates the function (temperature, humidity or combination)
- ▶ Mounting of ExPro probe (front/back side) appropriates use for duct or room application



Technical data	ExCos-D...
Power supply	24 VAC/DC +/- 20% (19,2 ... 28,8 VAC/DC) 50...60 Hz
Current, power consumption	150 mA, ~ 4 W, internal fuse 500 mA, without bracket, not removable
Galvanic isolation	supply - analogue output 1,5 kV (Ex 60 V)
Electrical connection	terminals 0,14 ... 2,5 mm <sup>2</sup> at integrated Ex e junction box
Cable entry	M16x1,5 Ex e approved, cable diameter ~ Ø 5...10 mm
Protection class	Class I (grounded)
Display	2 x 16 digits, dot-matrix with backlight, display for configuration, user guidance, parameter and actual value indication
Control elements	3 buttons for configuration
Housing protection	IP66 in acc. to IEC 60529
Housing material	aluminium casting, coated
Dimension / weight	L x W x H = 177 x 107 x 66 mm / ca. 950 g
Ambient temperature/humidity	-20 ... + 50 °C / 0 ... 95 % rH, non condensed
Storage temperature	-40 ... + 70 °C
Sensor connection	<b>only for ExPro-... sensors!</b> via plug-and-socket connection at front or back side of the transducer, to appropriate the use for room or duct mounting. <b>Attention:</b> only one ExPro-probe can be connected to one transducer!
ExPro sensors	please have a look on the separate data sheet for ExPro-... sensors
Measuring range	measuring ranges are scalable within the maximum measuring range
Maintenance	maintenance free, nevertheless maintenance must be complied with regional standards, rules and regulations
Response time of sensor	T90 ~ 1 sec.
Accuracy temperature	± 0,2 % of end value + accuracy of ExPro-... sensor ± 0,3 °C at 25 °C ± 0,025 °C/°C
Accuracy humidity	± 0,2 % of end value + accuracy of ExPro-... sensor 10 ... 90 %rH ± 2% and < 10%rH and > 90%rH ± 4%
Non linearity and hysteresis	± 0,1 % (± 0,1 % of end value + accuracy of ExPro-... sensor)
Start delay	5 sec.
Stability	long term stability < 0,2 % / year, temperature influence < 0,02 %/K, supply voltage influence < 0,01 %
Output	voltage U(V) or current I(mA) selectable via menu on site (at combi sensors not separately adjustable)
Output protection	against short circuit and external voltage up to 24 V, protected against polarity reversal
Voltage output U	from 0...10 VDC adjustable, invertible, burden > 1 kΩ, influence < 0,05% / 100 Ω
Current output I	from 0...20 mA adjustable, invertible, burden < 500 Ω, influence < 0,1% / 100 Ω, open circuit voltage < 24 V
Output at alarm mode	increasing or decreasing output signal, selectable on site, down to 0 VDC/0 mA or up to 10 VDC/20 mA
Wiring diagram (SB)	SB 2.0
Delivery (changeable on site)	output 4 ... 20 mA, output with decreasing alarm situation to 0V/0mA
Included in delivery	ExCos-D... with 3 screws 4,2x13 self-tapping
Installation area transducer	in Ex-area zone 1, 2, 21, 22

**Additional information for ExCos-D-A:**

Analogue output	(0) 4...20 mA
Ex i	Intrinsically Safe (IS)
Burden	max. 400 Ω
Accuracy	± 0,5 %
Plug	cable diameter Ø 6...8 mm
Delivery version ...-D-A	incl. 2 x plug

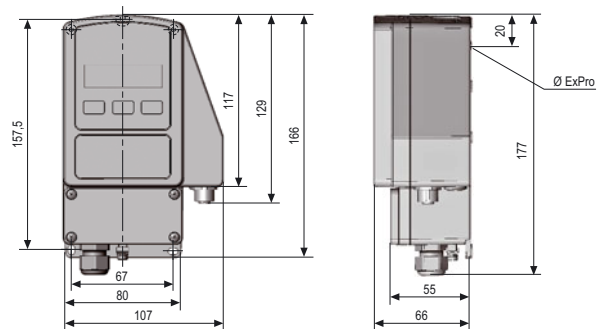
**Dimensions / Drillings**

Explosion proof	ExCos-D...
PTB-testet	PTB 07 ATEX 2061
acc. to ATEX directive	RL 94/9/EC (ATEX)
Approval for gas	II(2)G Ex e ma [ia] IIC T6 for zone 1, 2
Approval for dust	II(2)D Ex tD A21 [iaD] IP66 T80°C for zone 21, 22
Identification	CE Nr. 0158
EMC	89/336/EC EMC directive
Low voltage	73/23/EC low voltage directive
Protection type	IP 66 in acc. to EN 60529
Potential compensation	external PA-terminal, 4 mm <sup>2</sup>

Accessories	
<b>EXC-RIA-261</b>	LCD indicator (IS), installation in Ex-areas zones 1, 2, 21, 22, connectable direct to ExCos-... sensors with type ExCos-P...- A
<b>MKR</b>	Mounting bracket for round ducts up to Ø 600 mm
<b>MFK</b>	Mounting flange for probe positioning



**Electrical wiring**

ExCos-D... transducer required a 24 VAC/DC power supply. The supply has to be connected at terminal 1 (-/-) and 2 (+/+), the analogue output at terminal 3 (mA/V) and 4 (GND) for temperature, at terminal 5 (mA/V) and 4 (GND) for humidity. The electrical wiring must be realized via integrated Ex-e junction box in acc. to ATEX. Type of protection for the terminals is "Ex-e".

**Attention!** Before opening the junction box cover, the supply voltage must be shut off! The optional analogue output at ExCos-D-A is intrinsically safe. Note the maximum connection values of intrinsically safe parameters (see table below).

**Parameter**

Before starting parametrisation of ExCos-D... transducer an ExPro-... sensor must be connected. ExPro-... sensors are available as ExPro-CT...for single temperature measurement, as ExPro-CF... for single humidity measurement and as ExPro-CTF... for combined measurement of temperature and humidity. All types are connectable to an ExCos transducer but only one sensor to one transducer. In acc. with the sensor type you need to set parameter for one or two measuring ranges.

**Wiring diagram ExCos-D...**

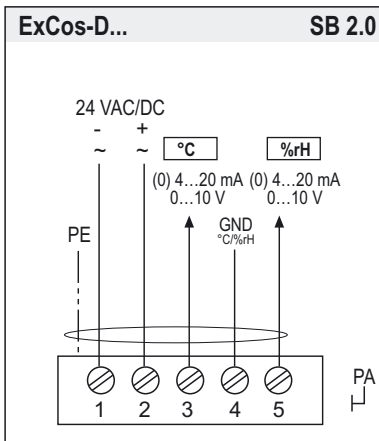

In acc. to the connected ExPro- sensor you get output signals at following terminal:

sensor	terminal	terminal
ExPro-CT...	3 - 4	
ExPro-CF...		4 - 5
ExPro-CTF...	3 - 4 und	4 - 5

It's either output mA or V adjustable.

**Display and Buttons**

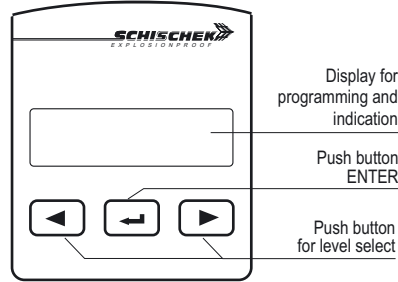

**Change operation- / parametrisation mode**

To change from operation to parametrisation mode and vice versa, push the enter button for minimum 3 seconds.

**Indication of data logging**

A blinking star in the display shows that datas received and the device is working.

**Wiring Ex i output (optional) at ExCos-D...A transducer**

**Terminals SB 3.0**

Male connector

The ExPro-... probe can be mounted to the front or the back side of the transducer. The protective cap must be removed. Unused connectors must be covered by a protective cap against mechanical damage and dirt

**Head side of ExCos-D-A sensor**

Connector 1 for output of sensor 1 (°C)  
Connector 2 for output of sensor 2 (%rH)

**Values IS (optional)**

U<sub>o</sub> = 15,8 V  
I<sub>o</sub> = 85 mA  
P<sub>o</sub> = 336 mW  
C<sub>i</sub> = 0  
L<sub>i</sub> = 0  
C<sub>o</sub>(IIC) = 0,33 nF  
L<sub>o</sub>(IIC) = 2 mH

**Password input**

The default / delievery setup is 0000. In this configuration the password input is not activated. To activate a password, go to menu point 20, change the 4 digits into your choosen numbers (e.g. 1234) and press Enter.

**Please keep your password in mind for next parameter change!**

Due to a new parameter setup the password is requested.

**Values intrinsically safe (IS) for ExPro sensors**

**Digital ExPro sensor**

U<sub>o</sub> = 7,9 V  
I<sub>o</sub> = 48 mA  
P<sub>o</sub> = 95 mW  
C<sub>i</sub> = 0  
L<sub>i</sub> = 0  
C<sub>o</sub>(IIC) = 1,3 nF  
L<sub>o</sub>(IIC) = 2 mH

**Important information for installation and operation**

**A. Installation, Commisioning, Maintenance**

The cable has to be drawn through the cable gland. After electrical connection the cable gland must be fixed tighten. IP66 must be fulfilled.

In acc. with operation ExCos sensors are maintenance free. Nevertheless maintenance must comply with regional standards, rules and regulations.

The sensors must not be opened by the customer. For outdoor installation a protective housing against rain, snow and sun should be applied. For electrical connection use the internal approved Ex-e junction box.

**Attention:** Note the explosion proof rules before opening the internal junction box. Cut off the power supply.

**B. ExPro sensors**

ExPro sensors are supplied with an intrinsic safe circuit from the ExCos-D.. transducer. Unused connectors must be covered by a protective cap.

**C. Long cabling**

For using long signal wires, shielded cables are recommended. The shield must be connected to the ExCos-D transducer inside the terminal box.

**D. Separate ground wires**

Use for supply and signal wires a separate ground.

**Parametrisation and commissioning of ExCos-D (-A) transducers after an ExPro sensor ist connected**

**Preparation of parametrisation/operation**





























































































































Operation ↔ Parametrisation, push  for 3 sec.

If password (PW) protection is active: put PW in, push 



**Change operation- / parametrisation mode**  
To change from operation to parametrisation mode push "enter button"  for minimum 3 seconds. Back over the menu save and exit.

**Example of parameters**  
Language english  
Range 0...+50 °C, 0...100%rH  
Output each 0...10 VDC, 0...20 mA  
Outputs Ex-i 4...20 mA

Menu	Function	Enter	Indication	Select	Enter	Next indication	Next selction	Enter	Next menu
Menu 1	DE, EN, FR select language: german, english, frensh		DE, EN, FR english	 					
Menu 2	no function - menu skip		deutsch, english, francais						
Menu 3	no function - menu skip								
Menu 4	unit sensor 1 select physical unit		unit sensor 1 °C	 					
Menu 5	range 1 adjust the measuring range		range 1 0..50 °C	 		range 1 0..50 °C	 		
Menu 6	no function - menu skip		↑ adjust lower limit			↑ adjust higher limit			
Menu 7	output V, mA select output signal as VDC or mA		output V/mA V	 					
Menu 8	output range 1 adjust the output range		output range 1 0..10V	 		output range 1 0..10V	 		
Menu 9	sensor error 1 select signal at sensor error		sensor error 1 10V / 20 mA	 					
Menu 10	output 1   select if signal output is increasing or decreasing		output 1   increasing	 					
Menu 11	unit sensor 2* select physical unit		unit sensor 2 %rH	 					
Menu 12	range 2* adjust the measuring range		range 2 0..100 %rH	 		range 2 0..100 %rH	 		
Menu 13	output range 2* adjust the output range		output range 2 0..10V	 		output range 2 0..10V	 		
Menu 14	sensor error 2* select signal at sensor error		sensor error 2 0V / 0 mA	 					
Menu 15	output 2*   select if signal output is increasing or decreasing		output 2   increasing	 					
Menu 16	output Ex-i 1 (option, only at ExCos-D-A) adjust 4...20 mA or 0...20 mA IS output signal		output Exi 1 4..20 mA	 		output Exi 1 4..20 mA	 		
Menu 17	output Ex-i 2 (option, only at ExCos-D-A)* adjust 4...20 mA or 0...20 mA IS output signal		output Exi 2 4..20 mA	 		output Exi 2 4..20 mA	 		
Menu 18	no function - menu skip		↑ adjust lower limit			↑ adjust higher limit			
Menu 19	display function select display on/off, illuminated or backlight off		display function on illuminated	 					
Menu 20	password select password protection		new password yes no	 		password 0000	 		
Menu 21	save and exit select save data / factory setting / discard or back to menu		save and exit save data	 					
Menu 22	Set offset 1 Add / subtract from measures value		set offset 1 0.00°C	 					
Menu 23	Set offset 2* Add / subtract from measures value		sett offset.2 0.00%rH	 					

# ExPro-... Digital Temperature-/Humidity Probe

Explosion proof digital probe exclusive connectable to ExCos-D / RedCos-D transducer for temperature and/or humidity measuring PTB-certified acc. to ATEX directive EC/94/9 for Zone 1, 2, 21, 22.

ExPro - CT...  
ExPro - CF...  
ExPro - CTF...

Subject to change!

Type	Function	Range	Sensor length	Applicable to transducer	Hazardous area
Fühler					
ExPro - CT...	Temperature Probe	-40...+125 °C	50/100/150/200 mm	ExCos-D, RedCos-D	Zone 1, 2, 21, 22
ExPro - CF...	Humidity Probe	0...100 %rF	50/100/150/200 mm	ExCos-D, RedCos-D	Zone 1, 2, 21, 22
ExPro - CTF...	Combi Probe	-40...+125 °C/0...100 %rF	50/100/150/200 mm	ExCos-D, RedCos-D	Zone 1, 2, 21, 22

Sensor length

## Application

### ExPro Sensors



### Application Room



### Application Duct

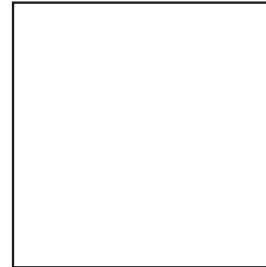

Technical data	ExPro-CT...	ExPro-CF...	ExPro-CTF...
Application for	Temperature Probe	Humidity Probe	Combi Probe Temperature and Humidity
Measuring Range	-40 °C...+ 125 °C	0...100 %rF	-40 °C...+ 125 °C / 0...100 %rF
Sensor type and length	ExPro-CT- 50 = 50 mm ExPro-CT-100 = 100 mm ExPro-CT-150 = 150 mm ExPro-CT-200 = 200 mm	ExPro-CF- 50 = 50 mm ExPro-CF-100 = 100 mm ExPro-CF-150 = 150 mm ExPro-CF-200 = 200 mm	ExPro-CTF- 50 = 50 mm ExPro-CTF-100 = 100 mm ExPro-CTF-150 = 150 mm ExPro-CTF-200 = 200 mm
Response time	T90 / 20 s	T90 / 4 s	T90 / 20 s, T90 / 4 s
Accuracy Temperature	+/- 0,3 °C @ 25 °C +/- 0,025 °C/°C + transducer		
Accuracy Humidity	+/- 2 % @ 10 ... 90 %rF, +/- 4% @ < 10%rF and > 90%rF + transducer		
Protection class	IP66 acc. to IEC 60529		
Material thermowell, protection tube	Stainless steel 1.4305, at length 50 mm in plastic max temperature 80°C (room temperature)		
Filter element	at humidity probe with plastic filter element pore size 100 µm		
Ambient temperature/humidity	- 40...+ 125 °C / 0...100 % rF		
Storage temperature	- 40...+ 125 °C		
Delivery	1 ExPro... probe with fast connection and gasket (EPDM) for duct installation		
Installation area probe	in Ex-area zone 1, 2, 21, 22		

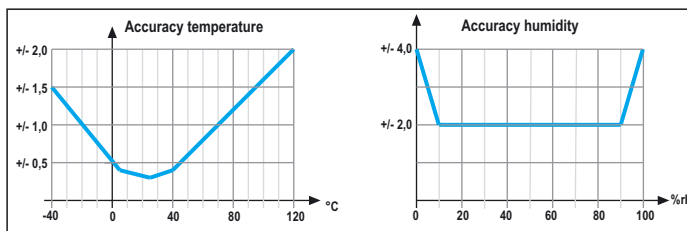

## Medium temperature

Temperature class	T6	T5	T4	T3	T2	T1
Medium temperature max [°C]	59	74	109	125	125	125

The correlation of max. medium temperatur and temperature class as well as the surface temperature is shown in table above.

## Values intrinsically safe

Ui = 7,9 V      Ci = 0  
Ii = 48 mA      Li = 0  
Pi = 95 mW

## Accessories

- MFK** Flange for duct mounting, for variable depth of immersion in ducts.
- TH-VA** Immersion sleeve stainless steel V4A 1.4571, length 120 mm. other length on request.
- FA-VA** Filter element stainless steel, pore size 10µm **not for high humidity!**
- MKR** Mounting bracket for duct Ø 600 mm.

**What is a ExPro-probe?**

A ExPro probe is a sensor head resp. measuring element which is in combination with a ExCos-D transducer for temperature-, humidity or combi temperature/humidity measuring. ExPro probes are only for use with ExCos-D... transducer. The connection should be done with a socket on the front resp. on the back side of the transducer but only 1 ExPro module can be used.

**Dimensions**

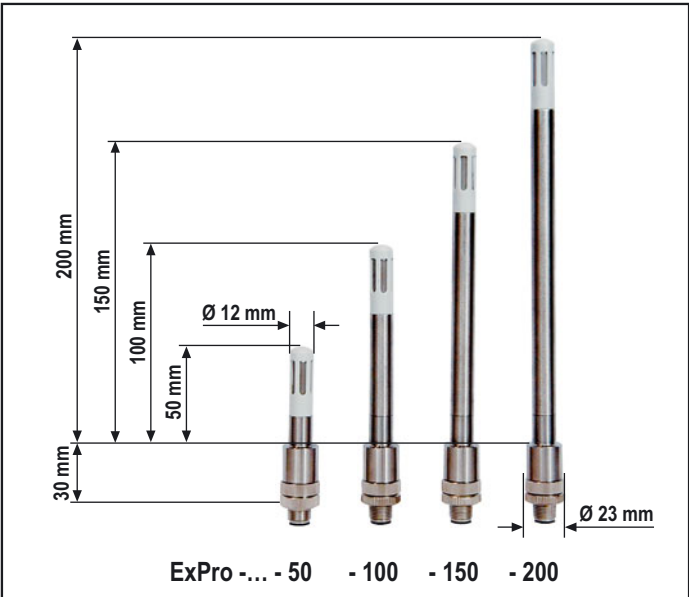

**Important informations for installation and use**

**A. ExPro Probe**  
The power of the ExPro probe is supplied via an intrinsically safe (IS) circuit from the ExCos-D. Unused probe-entries at the ExCos-D have to be closed with the black caps.

**B. Temperature-flow**  
In case of temperature measuring over the max. allowed environmental temperature of 50 °C of the transducer, it has to be watched, that no temperature flow over the probe takes place. The mounting of the probe has to make sure, that mistakes due to heat-dissipation are within the tolerance-limits and the max. allowed environment temperature is not exceeded.

**C. Mounting**  
The probe is being screwed into the socket of the ExCos-D. The probe cannot be opened, as parts of the element are moulded. A small distance tolerance between ExCos-D (transducer) and ExPro (probe) has to be accepted due to production conditions.

**Mounting duct probe (Back side ..Cos-D)**

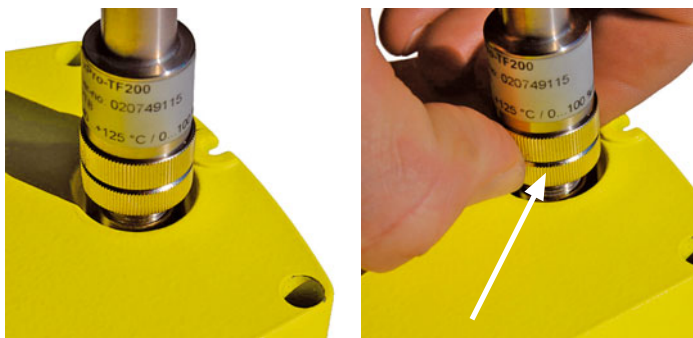

For mounting the probe plug the socket and screw on the sensor by turning the lower knurled thumb clock wise. Just screw hand tight. A small clearance between ExCos-D (transducer) and ExPro (probe) has to be accepted due to production conditions.

**Mounting flange (MFK) for duct installation**

The flange is moved over the probe and fix it with the side wise adjusting screw. The flange can be mounted with the 4 screws direct to the duct.

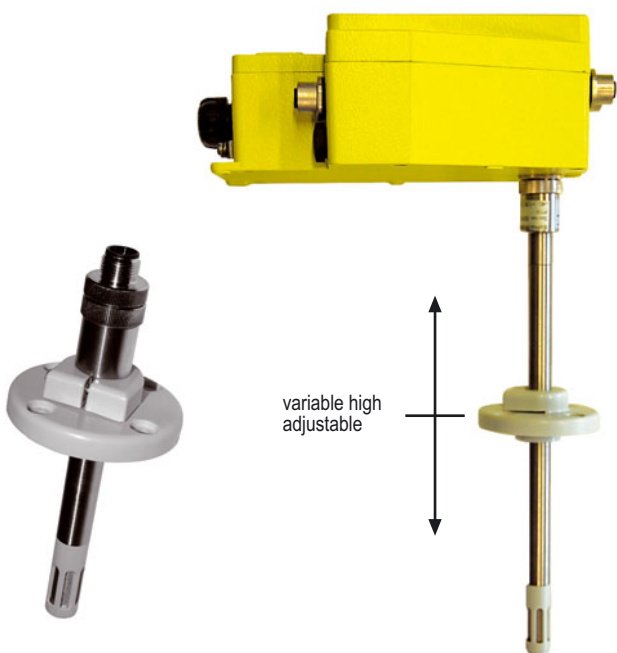

**Mounting room probe (terminal box side ..Cos-D)**



For mounting the probe plug the socket and screw on the sensor by turning the lower knurled thumb clock wise. Just screw hand tight. A small clearance between ExCos-D (transducer) and ExPro (probe) has to be accepted due to production conditions.