

**Transducer 24 VAC/DC, with intrinsically safe circuits for passive sensors in hazardous locations Zones 0, 1, 2, 20, 21, 22; with display**

**Serie EX-LINE**

**Type EXL-IMU-1**

### APPLICATION

The transducer is an associated intrinsically safe device for transmitting signals of passive sensors in hazardous areas into safe areas like Pt100, Ni1000, resistor sensors .... The sensor signals are transformed in signals (0...10 V- and 0...20 mA). The programming and adjustments of sensors are carried out on the device. Different sensor characteristics are integrated (see table 1).

Each module has a back light LCD display, which is used for programming, to indicate alarm signals and during operation. The display shows the actual value. A potential free contact is integrated for error recognition.

The measurement ranges of sensors and the output signals can be adjusted to any requirements of the system. For programming no tools are necessary. The menu prompt is indicated over the display.

### TECHNICAL DATAS

Supply/Frequency	24 VAC/DC +/- 20 %, 50...60 Hz
Nominal current, Power consumption	100 mA, ca. 3,6 W, internal fuse without socket
Sensor input	Intrinsically safe circuit for passive sensors
Suitable sensors	see table 1
Sensor selection	accomplished by the customer, with menu prompt
Programming	direct on device, without additional tools
Sensor connection	2-3-4 wire on light blue terminals
Wire compensation	2-wire push button, 3- and 4 -wire automatically
Acceptable wire resistor	< 100 Ohm
Stability	stability < 0,2 % / year, temperature influence < 0,02 %/K, supply voltage influence < 0,01 %, setting time 0,5 sec. < 0,3 % end value
Accuracy	Galvanic isolation
Galvanic isolation	between out-, input and supply voltage
A/D-converter	measure range 16 Bit, outputs 12 Bit
Outputs	Voltage U and current I parallel available with tie point (GND) against short circuit and separate source voltage < 30 V
Outputs are protected	0...10 V- adjustable, burden < 500 Ω, influence < 0,05%
Voltage output U	0...20 mA adjustable, burden < 750 Ω, influence < 0,1% open circuit voltage < 26 V
Current output I	increase or decrease selectable, 0 V-/0 mA or 10 V-/20 mA
Signals in alarm mode	4 1/2 digits LCD-Display + special signs, back light status indication and actual value display (blank)
Display	Push button for configuration/active mode, 5 buttons for setup, setup, menu prompt and parameter per display over 1 potential free contact + output + display
Buttons	setup, menu prompt and parameter per display over 1 potential free contact + output + display
Failure / alarm indication	Detection
Detection	Alarm indication 1 and 2
Alarm indication 1 and 2	Failure- / alarm contact
Failure- / alarm contact	work-/storage temperature
work-/storage temperature	Electrically connection
Electrically connection	Housing
Housing	Dimensions and weight
Dimensions and weight	Type of protection
Type of protection	Protection class
Protection class	CE 0158
CE 0158	Included in price
Included in price	Installation area
Installation area	

**II(1)GD [EEx ia] IIC  
Zone 0, 1, 2, 20, 21, 22  
PTB-approved acc. to  
ATEX**



### CONNECTABLE SENSORS - TABLE 1

Sensor table	Range	Characteristics	unit
Pt 100 DIN	-200...+850°C	temp.-linear	°C
Pt 500/1000 DIN	-200...+850°C	temp.-linear	°C
Ni100/200/500/1000 DIN	-60...+180°C	temp.-linear	°C
LS-Ni 1000 (Siemens)	-30...+130°C	temp.-linear	°C
KP 250 (Kieback&Peter)	-50...+150°C	temp.-linear	°C
LF 20 (Honeywell Special 1)	-20...+100°C	temp.-linear	°C
Resistor without slider	0... 1 kΩ	resistor-linear	variable
in display figure 2	0... 10 kΩ		
Resistor with slider	0... 10 kΩ	resistor-linear	variable
in display figure 3	0... 1 kΩ		
DFK... (Special 2)	x...y Pa	angle linear	Pa
VFK... für VAV (Special 3)	x...y m/s	angle SQRT	m/s

### EEx-i circuits - TABLE 2

Nominal value	Maximal value on the terminal	
	II(1)GD [EEx ia] IIC	II(1)GD [EEx ia] IIB
<b>Terminals</b>	<b>22-23-24-25</b>	<b>22-23-24-25</b>
Voltage U <sub>0</sub>	7,5 V	7,5 V
Current I <sub>0</sub>	5 mA	5 mA
Power P <sub>0</sub>	10 mW	10 mW
Capacity C <sub>0</sub>	1,2 µF	4,9 µF
Inductivity L <sub>0</sub>	10 mH	50 mH

**The maximum values must not be exceeded!**  
Please check your external capacities and inductivities in acc. to the length of the cable and the method of installation.

### ATTENTION!

- For installation or maintenance official standards and rules must be adhered to!
- The energy of intrinsically safe circuits are below the level to start an explosion in the event of a spark.
- Intrinsic safe circuits must be installed with light blue coloured cables and separate installed from non intrinsic safe circuits. Distance between terminals of intrinsic safe circuits and non intrinsic safe circuits must be a minimum of 50mm.
- The EXL-IMU-1 modules must be installed in the safe area. Sensors must be passive and potential free for use in hazardous locations in zone 0, 1, 2 and 20, 21, 22.
- For applications in zone 20 and 21 you may use only sensors which apply the category 1D or 2D. In zone 0 only sensors which apply the category 1G
- Pay attention to the max values for sensors and wiring, listed in table 2.

### ELECTRICAL CONNECTION

#### Temperature-/Humidity sensors Resistors linear, Potentiometer

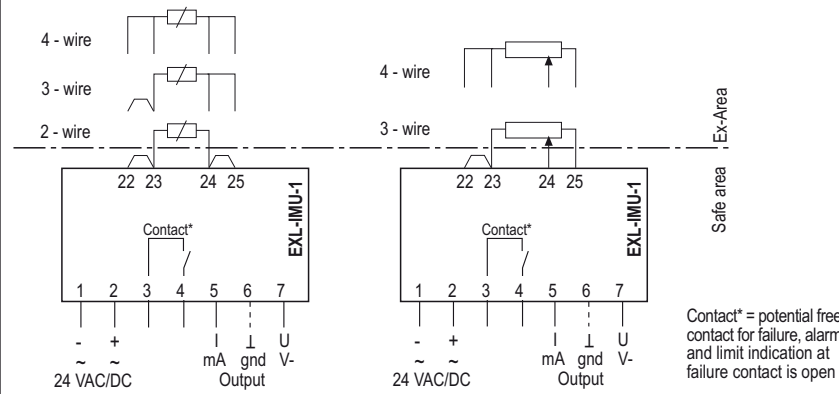

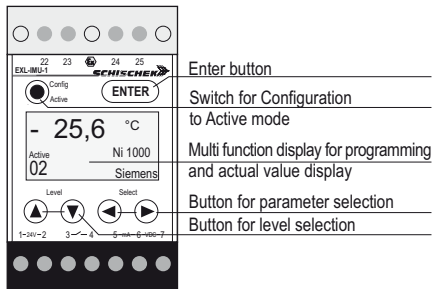

### Switching Configuration - Active

With the switching between "Active" = Operating modus and Config" = Configuration mode, changes from the working function into the programming function. The switching from Active to Config is made by pushing one time the Config button (ConF in display) and then push the ENTER and Level up buttons at the same time.  
After setup, start the active mode by pushing the config button.

Active → Config      Config → Active  
1.      1. 1x  
2. +      2. +

### Failure- and Alarm Indication

Different failure or alarm signals are indicated by contact and by display warnings. The following pictures show the most common errors and there cause.

Display	Failure
	Actual display value is flashing at low measuring range Sensor error, actual value is lower than adjusted range or there is a short circuit fault at wiring, Contact is active - display shows Error Sensor Range
	Display actual value is blinking at high measuring range Sensor error, actual value is higher than adjusted range or the wiring is open. Contact is active - display shows Error Sensor Range
	value over or under measurement range Value is over or under adjusted range Display shows Error Range, Contact isn't active
	Error status at wire compensation Wire resistors more than 100 Ohm aren't accepted.

### Notes to Sensors

For the following sensors there are separate datasheets for programming and setup available:  
Sensor type      Ring balance, Potentiometer  
Resistors with and without slider are different in the setup Level 01. Without slider is figure 2 + resistor value and with slider is figure 3 + resistor value.  
Ring balance linear and root extraction (m/s) are different in Level 01 Sensor selection. Special 2 is linear for Δp and Special 3 for m/s

## Programming and Setup "Step by Step"

TEMPERATURE SENSORS				HUMIDITY SENSORS			
Connection		Example: Pt100 DIN 2-wire		Connection		Example: 1kOhm 4 wire	
Range		-20...100 °C		Range		0...100 %	
Output		2-10 V, 4-20 mA		Output		0-10 V, 0-20 mA	
Limit low		0°C		Output in alarm situation		decrease to 0 V / 0 mA	
Limit high		80°C		Limits		not applied	
Active → Config		1.  1x      2.  +		Active → Config		1.  1x      2.  +	
Level	Function	Display	Select	Level	Function	Display	Select
01	Select sensor type	Pt 100 DIN		01	Select sensor type	0-1kOhm (2)	
02	Select 2-3-4 wire	2-wire		02	Select 2-3-4 wire	4-wire	
03	wire compensation	ENTER Sensor short circuit, ENTER		03	wire compensation		This Level is automatically Passed
04	Select start of measuring range	-20.0 °C      -20 °C		04	Select start of measuring range	0.0 Ω      0 Ohm	
05	Select end of measuring range	100 °C      100 °C		05	Select end of measuring range	1000.0 Ω      1000 Ohm	
06	Select unit	The functions in Level 06 .. 09 are at temperature sensors preseted. Unit is °C, Decimal point is 0.1°C Begin and end measuring values depends on sensor type		06	Select unit	%rF      %rF	
07	Select decimal point			07	Select decimal point	-.-.-      -.-.-	
08	Select start of display value			08	Select start of display value	0.00 %rF      0.00 %rF	
09	Select end of display value			09	Select end of display value	100.00 %rF      100.00 %rF	
10	Output V/mA in fault conditions high or low	low		10	Output V/mA in fault conditions high or low	low	
11	Analogue output V start value	2.0 V      2.0 V		11	Analogue output V start value	0.0 V      0.0 V	
12	Analogue output V end value	10.0 V      10.0 V		12	Analogue output V end value	10.0 V      10.0 V	
13	Analogue output mA start value	4.0 mA      4.0 mA		13	Analogue output mA start value	0.0 mA      0.0 mA	
14	Analogue output mA end value	20.0 mA      20.0 mA		14	Analogue output mA end value	20.0 mA      20.0 mA	
15	Contact low limit value	0.0 °C      0.0°C		15	Contact low limit value	0.00 %rF      0.00 %rF	
16	Contact low limit On/Off	On		16	Contact low limit On/Off	Off	
17	Contact high limit value	80.0°C      80.0°C		17	Contact high limit value	100.0 %rF      100.0 %rF	
18	Contact high limit On/Off	On		18	Contact high limit On/Off	Off	
19	Actual value On/Off	Pt 100 DIN		19	Actual value On/Off	0-1kΩ	
Config → Active 1.  1x				Config → Active 1.  1x			

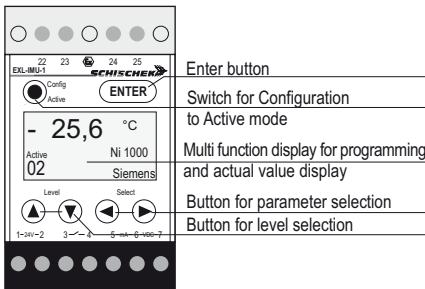

### Switching Configuration - Active

With the switching between "Active" = Operating mode and "Config" = Configuration mode, changes from the working function into the programming function. The switching from Active to Config is made by pushing the Config button (ConF in display) and then push the ENTER and Level up button at the same time. After setup, start the active mode by pushing the config button.

- Active → Config      Config → Active
1. +
  2. +

### Failure- and Alarm Signalisation

Different failure or alarm signal are indicated by contact and by display warnings. Following pictures shows the most indicated errors and there cause.

Display	Failure
	Actual display value is flashing at low measuring range Sensor error actual value is lower than adjusted range or there is a short circuit fault at wiring. Contact is active - display shows Error Sensor Range
	Display actual value is blinking at high measuring range Sensor error actual value is higher than adjusted range or the wiring is open. Contact is active - display shows Error Sensor Range
	value over or unter measurement range Value is over or unter adjusted range Display shows Error Range, Contact isn't active
	No value in display Select in Level 19 configuration mode Display On.
	Error status at wire compensation Wire resistors more than 100 Ohm aren't accepted.

### Notes to Sensors

For the following sensors there are separate datasheets for programming and setup available:  
Sensor type    Temperatur sensor, Humidity sensor

Resistors with and without slider are different in the setup Level 01. Without slider is figure 2 + resistor value and with slider is figure 3 + resistor value.

Ring balance linear and root extraction (m/s) are different in Level 01 Sensor selection. Special 2 is linear for  $\Delta p$  and Special 3 for m/s

## Programming and Setup "Step by Step"

RING BALANCE ( $\Delta p$ , m/s)				POTENTIOMETER			
Range		Example: 0 ... 40 Pa		Connection		Example: 0-10 kOhm with slider	
Output		U/I 0...10 VDC/0...20 mA		Range		0...10 kOhm	
Output in alarm situation		increase to 10 V / 20 mA		Output		0-10 V, /0-20 mA	
Limits		not applied		Output in alarm situation		increase to 10 V / 20 mA	
Limits				Limits		1.000 kOhm, 9.000 kOhm	
Active → Config		1.  1x    2.  +		Active → Config		1.  1x    2.  +	
Level	Function	Display	Select	Level	Function	Display	Select
01	Select sensor type	Sensor 01    Special 2	Special 2 (linear)	01	Select sensor type	Sensor 01    0-10k $\Omega$ 3	0-10 kOhm (3) 3 means slider connection
02			preselect no function	02	Select 2-3-4 wire	Wire 02    0-10 k $\Omega$ 3	3
03	Calibration modus	CAL 03 Start    Special 2	ENTER (Start) draw the needle to 0Pa ENTER	03	Wire compensation	Start Wire Compensation 03    0-10k $\Omega$ 3	push ENTER potentiometer turn left (low limit) push ENTER
		CAL 03 End    Special 2	End value needle per hand to 40Pa ENTER	04	Select begin of measuring range	Range 04 Start    0.000 k $\Omega$ 3	0.000 kOhm
04			preselect no function	05	Select end of measuring range	Range 05 End    10.000 k $\Omega$ 3	10.000 kOhm
05			preselect no function	06	Select unit	Range 06 Display    k $\Omega$ 3	kOhm
06	Select unit	Range 06 Display    Pa    Special 2	Pa	07	Select decimal point	Range 07 Display    k $\Omega$ 3	--
07	Select decimal point	Range 07 Display    Pa    Special 2	--	08	Select start of display value	Range 08 Start Display    0.000 k $\Omega$ 3	0.000kOhm
08	Select start of display value	Range 08 Start Display    Pa    Special 2	0.00	09	Select end of display value	Range 09 End Display    10.000 k $\Omega$ 3	10.000 kOhm
09	Select end of display value	Range 09 End Display    Pa    Special 2	40.00	10	Output V/mA in fault conditions high or low	Output 10 Error    high	high
10	Output V/mA in fault conditions high or low	Output 10 Error    Special 2	high	11	Analogue output V start value	Output 11 Start    0.00 V    Special 2	0.0 V
11	Analogue output V start value	Output 11 Start    Range V    Special 2	0.00 V	12	Analogue output V end value	Output 12 End    10.0 V    Special 2	10.0 V
12	Analogue output V end value	Output 12 End    Range V    Special 2	10.0 V	13	Analogue output mA start value	Output 13 Start    0.0 mA    Special 2	0.0 mA
13	Analogue output mA start value	Output 13 Start    Range mA    Special 2	0.0 mA	14	Analogue output mA end value	Output 14 End    20.0 mA    Special 2	20.0 mA
14	Analogue output mA end value	Output 14 End    Range mA    Special 2	20.0 mA	15	Contact low limit value	Limit 15    0.00 Pa    Special 2	0.0
15	Contact low limit value	Limit 15    Range Pa    Special 2	0.0	16	Contact low limit On/Off	Limit 16 On    Off    Special 2	Off
16	Contact low limit On/Off	Limit 16 On    Range Pa    Special 2	Off	17	Contact high limit value	Limit 17    40.00 Pa    Special 2	40.0
17	Contact high limit value	Limit 17    Range Pa    Special 2	40.0	18	Contact high limit On/Off	Limit 18 On    Off    Special 2	Off
18	Contact high limit On/Off	Limit 18 On    Range Pa    Special 2	Off	19	Actual value On/Off	Display On 19    Special 2	
19	Actual value On/Off	Display On 19    Special 2					
Config → Active 1.  1x				Config → Active 1.  1x			

# Erklärung der EG-Konformität

# Declaration of EC-Conformity

# Attestation de conformité CE

Wir, die  
(Name des Herstellers)  
(Anschrift)

We, the  
(manufacturer name)  
(address)

Nous, la  
(nom de fournisseur)  
(adresse)

**Schischek GmbH  
Mühlsteig 45 Gewerbegebiet Süd 5  
90579 Langenzenn / Germany**

erklären in alleiniger Verantwortung gemäß den Bestimmungen der Richtlinien :

declare under our sole responsibility, following the provisions of directives :

déclarons sous notre seule responsabilité conformément aux dispositions de directives :

**2004/108/EG  
94/9/EG**

**2004/108/EC  
94/9/EC**

**2004/108/CEE  
94/9/CE**

dass das Produkt :

that the product :

que le produit :

## EXL-IMU-1

auf das sich diese Erklärung bezieht, mit den folgenden Normen oder den normativen Dokumenten übereinstimmt :

to which this declaration refers, conforms with the following standards or normative documents:

auquel se réfère cette déclaration, est conforme aux normes ou autres documents normatifs :

**EN 50081-1,  
EN 61000-4-2  
EN 61000-4-4  
EN 61000-4-5**

**EN 50014  
EN 50020**

Kennzeichnung :

Marking :

Marquage :



**II (1)GD [EEEx ia] IIC PTB 03 ATEX 2092**

Geschäftsführer :  
(Ort und Datum)  
(Name und Unterschrift)

Manager :  
(Place and date of issue)  
(Name and signature)

Directeur gérant :  
(Lieu et date)  
(Nom et signature)

**Langenzenn, 29.08.2011**

**Roland Graf**

Die Erklärung bescheinigt die Übereinstimmung mit den genannten Richtlinien, sie beinhaltet jedoch keine Zusicherung von Eigenschaften im Sinne des Produkthaftungs-Gesetzes. Die Sicherheitshinweise der mitgelieferten Produktdokumentation sind zu beachten. Bei einer mit dem Hersteller nicht abgestimmten Änderung des Gerätes und/ oder bei Nichtbeachtung der Sicherheitshinweise verliert diese Erklärung ihre Gültigkeit.

The declaration certifies the conformity with the directives mentioned, it does not, however contain any warranty of qualities as defined in the act on product liability. The safety instructions contained in the product documentation accompanying the product have to be observed. If apparatus is modified without having obtained the manufacturer's prior consent and/or if instructions are not followed, this declaration will become void.

La déclaration certifie la conformité avec les dispositions nommées, elle ne comporte cependant aucune garantie de caractéristiques dans le sens de la loi sur la responsabilité du producteur pour vice de la marchandise. Les instructions en matière de sécurité dans la documentation du produit, livrées avec le produit, sont à observer. En cas de modification de l'appareil n'ayant pas eu l'accord du fabricant et/ou cas de non-respect des instructions de sécurité, cette déclaration perd sa vigueur.

Importeur :

Importer :

Importateur :