

**Electrical, explosionproof valve actuators
for hazardous areas zones 1, 2, 21, 22 – force 2000 N - tested acc. to ATEX**

Type EXV-20...

**List 3.1
EX-VENT**

APPLICATION

EXV-20... Valve actuators for control valve bodies or on-off function. Explosionproofed in acc. with "flameproof enclosure" and dust ignition proof, PTB-tested. Installation in hazardous areas zone 1, 2, 21, 22. The actuators are 100% overload protected and can be stopped in any position. The controller must be stable and should not pulse.
Application: For industrial plants. For **Offshore** applications we recommend the special types **EXV-20.../CT and EXV-20.../VA**.

TECHNICAL DATA

Type	EXV-20230	EXV-20230-P	EXV-20230-Y	EXV-20230-Y/I
Supply voltage ± 10%	230 V/50 Hz	230 V/50 Hz	230 V/50 Hz	230 V/50 Hz
Type	EXV- 2024	EXV- 2024-P	EXV- 2024-Y	EXV- 2024-Y/I
Supply voltage ± 10%	24 VAC/DC	24 VAC/DC	24 VAC/DC	24 VAC/DC
Power consump. motor	~15 VA	~15 VA	~15 VA	~15 VA
capacitive load	capacitive load	capacitive load	capacitive load	capacitive load
	$I_{START} \gg I_{TYP}$	$I_{START} \gg I_{TYP}$	$I_{START} \gg I_{TYP}$	$I_{START} \gg I_{TYP}$
Force	2000 N	2000 N	2000 N	2000 N
Running time	~6 sec/mm	~6 sec/mm	~6 sec/mm	~6 sec/mm
Stroke, in dep. of type	10 - 40 mm	10 - 40 mm	10 - 40 mm	10 - 40 mm
Control mode	on-off	on-off	2... 10 V	4... 20 mA
	3 pos	3 pos		
Input resistance			80 KΩ (~0,2 mA)	500 Ω
Feedback signal	-	1000 Ω	2... 10 V	2... 10 V
Endswitches	no endswitches, actuators are overload protected			
Ambient temperature	0... 40 °C, non-condensing			
Housing material	Aluminium baked varnish			
Rod material	1.4034			
Weight	~6 kg			
Indication	CE Nr. 0158			
Permission	PTB-tested acc. to directive 94/9/EC (ATEX)			
Certificate	PTB 99 ATEX 1103			
Explosionproof	Ⓜ II2G EEx d IIC T6, CENELEC EN 50014/ EN 50018 Ⓜ II2D IP65 T95°C, CENELEC EN50281-1-1			
External PE-connector	Connectable lines: 4 mm ² multiple-wire, 6 mm ² single-wire			
Prot. in acc. with EN 60529	IP54, IP56/IP67 on request			
Operating mode	S3 80%ED EN60034-1, minimum run time of the actuator >1 sec.			
Included	Actuator with 0.3m cable and protection tube, II2G/D EEx e terminal box with mounting bracket			
Installation area	hazardous areas zone 1, 2, 21, 22			



ACCESSORIES

- /K** Heater for outdoor application and/or at high humidity for reducing water condensation. Power consumption of the heater ~16 W.
- /CT** All housing parts aluminium with **Amercoat** varnish for **Offshore** applications.
- /VA** All housing parts in **stainless steel AISI 316** for **Offshore** application.
- /2EE** 2 integral, potential free aux. switches, switching in end-positions.
- /HV** Emergency manual operation.
- Adaptors** different types for different valve bodies.
- EXC-HSV** 2 external aux. switches, potential free contacts, each adjustable.
- EXC-K/HSV** EEX-Terminal box for EXC-HSV.
- MOL-NG 24** Battery power pack, standby unit, 24V.
- MOL-EH1** Electronic aux. switch, connectable to actuators type EXV-...-Y, panel mounting.
- /L16** Special Type with running time ~16 sec/mm.

DIMENSIONS

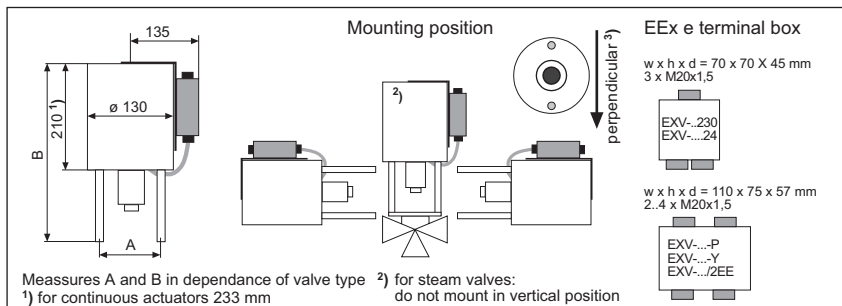

ATTENTION

- The cable of the actuator must be installed in a fixed position and protected against mechanical damage.
- For installation, use and maintenance the official standards and rules must be applied.
- 3) **With horizontal installation position of the actuator, the two spacer rods must form a vertical level.**
- Temperature class T6 is only for the actuator, you have to guarantee max. temperature of valves and tubes on site.
- **The EEX actuators may only be opened by the manufacturer to guarantee explosionproof and for warranty.**
- For outdoor installation a heater and a weather protective housing against rain, snow and sun is required.
- After installation all componetes must fulfil the protection class IP65 acc. EN60529.

ELECTRICAL CONNECTION

Attention: • Voltage at terminal 2: rod is extending.
• For continuous actuators see reverse.

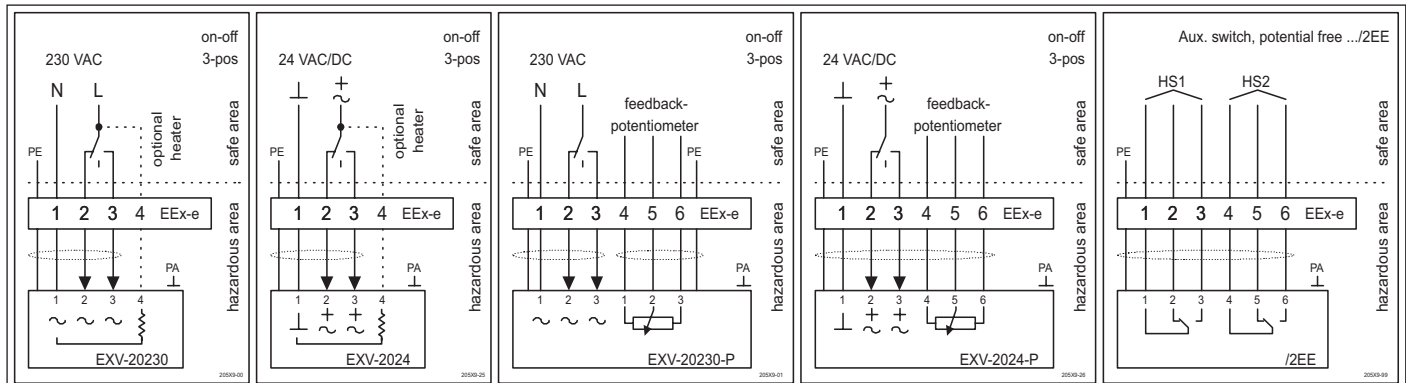

subject to change

Ventilstantriebe Valve actuators



EXV-8/2024-Y
EXV-8/2024-Y/I
EXV-8/20230-Y
EXV-8/20230-Y/I

Elektrischer Anschluß "Y" oder "Y/I" Electrical connection "Y" or "Y/I"

Elektrischer Anschluß Electrical connection

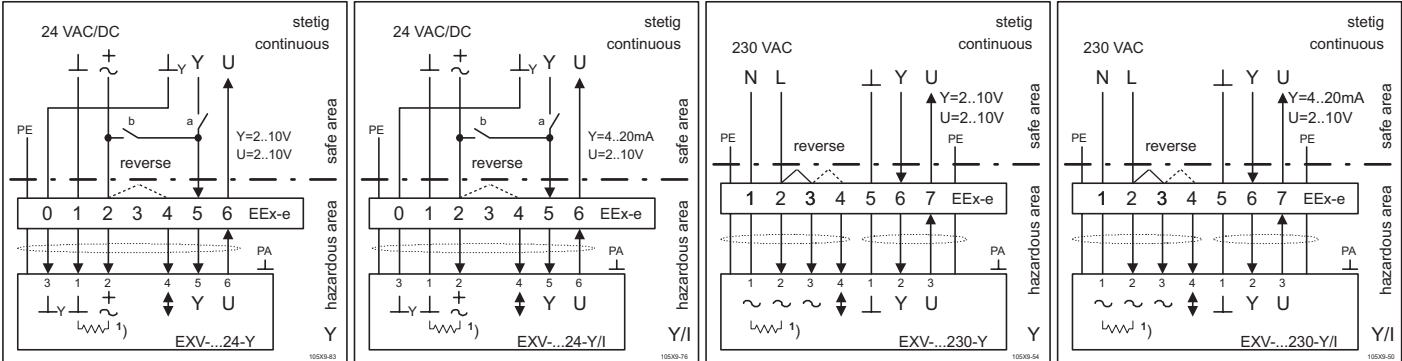

Achtung/Attention: 24 V, "Y" & "Y/I"

Für Inversbetrieb, Brücke 2 - 4 erforderlich.
Connection 2 - 4 for reverse function.

Y- \downarrow Y = Stellgröße
manipulated variable

U- \downarrow Y = Stellungsanzeige
feedback signal

Masse/Ground

Die beiden Masseleitungen 0 und 1 müssen eine galvanische Verbindung haben. Diese Verbindung sollte sich an der Stromversorgung oder am Reglerausgang befinden.

The two ground lines 0 and 1 must have an electrical connection. This connection should be made at the power supply or the controller output.

¹⁾ optionale Heizung / optional heating

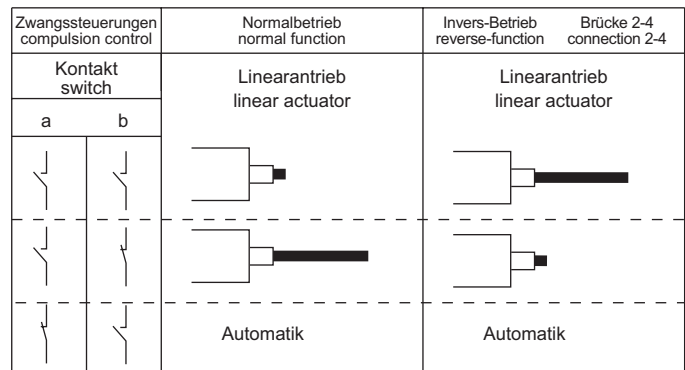

Montage Ventilkörper an Antrieb EXV...

- Der Antrieb wird werkseitig mit eingefahrener Hubstange ausgeliefert!
- Den Antrieb auf den Ventilkörper stecken und mittels der mitgelieferten Muttern (1) befestigen.
- Überwurfmutter (2) lösen und Verbindungsteile mittels der Verbindungsmutter (3) locker auf die Ventilspindel schrauben. Ventilspindel dabei ganz hineindrücken!
- Zwischen dem Schraubenkopf von Schraube (4) und der Hubstange des Antriebes entsprechend dem Ventilhub Platz lassen, **Ventilhub vorher messen und notieren**. Justage erfolgt über Schraube (4) bzw. Verbindungsmutter (3).
- Die beiden Kontermuttern (5) handfest anziehen. Die Ventilspindel mit den Verbindungsteilen herausziehen und mit Hilfe der Überwurfmutter (2) auf der Hubstange befestigen. **Nicht zu fest anziehen (max. 4 Nm - Zerstörung der internen Verdrehsicherung!)**
- Antrieb elektrisch nach dem Antrieb beiliegenden Anschlussschema anschließen.
- Antrieb elektrisch ausfahren lassen. Bei Stetig-Antrieben mit Signal 20 mA bzw. 10 VDC oder durch Auflegen der Betriebsspannung auf Klemme 4 falls noch kein Stellsignal vorhanden ist. Funktion überprüfen - schließt Ventil? Eine Nachjustage ist mittels Schraube (4) möglich.
- Alle Verbindungen fest anziehen, dabei darauf achten, daß nicht gegen die Hubstange gekontert wird - Zerstörung der internen Verdrehsicherung.
- Der Antrieb ist betriebsbereit.

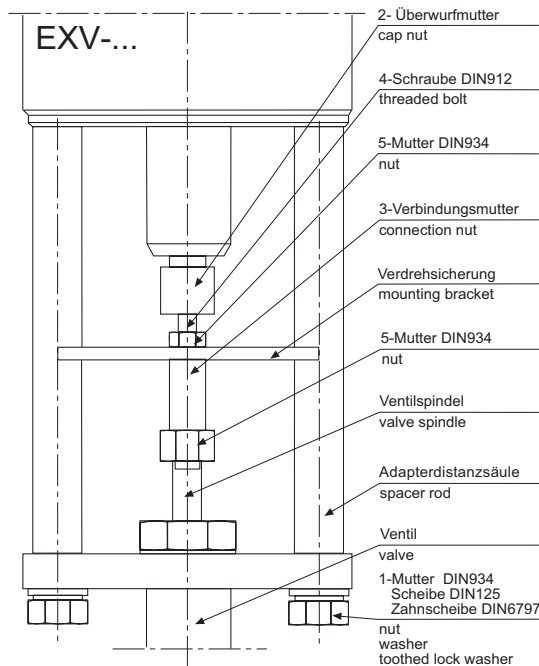

Mounting instructions for the valve body to the actuator EXV...

- The actuator will be delivered with retracted stroke.
- Place the actuator on the valve body and attach with the nuts and washers (1) provided.
- Remove the cap nut (2) and screw the connecting parts with the connecting nut (3), taking care not to damage the valve spindle. The spindle should be retracted as far as possible into the valve body.
- Allow enough distance between the threaded bolt head (4) and the rod of the actuator, **noting the travel of the valve spindle**. Any adjustment can be done by screwing the bolt (4) into the connection nut(3). Tighten both counter nuts firmly.
- Draw out the valve spindle with the connecting parts until contact is made to the threaded actuator rod and join with the cap nut (2). **Do not overtighten (max. 4 Nm) otherwise damage will be cause to the mounting bracket.**
- Connect the actuator to the supply in accordance with the enclosed wiring diagram.
- Operate the actuator electrically to fully extend the actuators rod. For modulated controlled actuator with a 20 mA or 10 VDC positioning signal or by connecting to load via terminal 4 (if no positioning signal available). Visual check that the valve is closed. Minor adjustment to the travel can be achieved by turning the threaded bolt (4).
- Secure all connections, take care not to operate the actuator against the stroke otherwise damage to mounting bracket may occur.
- The actuator is ready to operate.

DRAWING

