

InBin-A... transducer for switching sensors

Electrical transducer for switching sensors

24 VAC/DC supply voltage, output potential free switching contact

InBin - A1

InBin - A2

InBin - A5

Subject to change!

Compact . Easy installation . Universal . Cost effective . Safe

Type	Channel	Supply	Output switch	Max. ratings	Wiring
InBin - A1	1 ×	24 VAC/DC	pot. free contact	250 V, 0.1A / 30 V, 0.5 A	SB 1.0 / SB 4.0
InBin - A2	2 ×	24 VAC/DC	pot. free contact	250 V, 0.1A / 30 V, 0.5 A	SB 2.0 / SB 4.0
InBin - A5	5 ×	24 VAC/DC	pot. free contact	250 V, 0.1A / 30 V, 0.5 A	SB 3.0 / SB 4.0

Product views / Application

InBin-A1



InBin-A2



InBin-A5

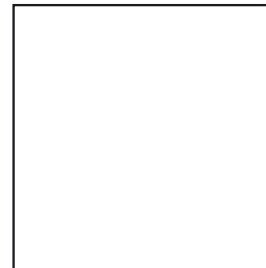

Description

The new InBin-A... transducer generation (available in 1-,2- and 5-channel version) is a revolution for switching sensors in HVAC systems, in chemical, pharmaceutical, industrial and Offshore-/Onshore plant. IP 66 protection, small dimension, universal functions and technical data guarantee safe operation even under difficult environmental conditions.

Highlights

- ▶ Industrial sensor
- ▶ Integrated junction box
- ▶ Power supply 24 VAC/DC
- ▶ Output potential free switching contact
- ▶ Display for switching state indication
- ▶ Fix starting bypass time for two channels
- ▶ Compact design and small dimension (L × B × H = 177 × 107 × 66 mm)
- ▶ Robust aluminium housing in protection class IP 66
- ▶ Down to -20°C ambient temperature applicable

Technical data	InBin - A...
Power supply	24 VAC/DC \pm 20% (19,2...28,8 VAC/DC) 50...60 Hz
Current, power consumption	150 mA, ~ 4 W, internal fuse 500 mA, without bracket, not removable
Galvanic isolation	supply – output 1,5 kV
Electrical connection	terminals 0,14...2,5 mm ² at integrated junction box
Cable entry	2 \times M16 \times 1,5, cable diameter ~ \varnothing 5...10 mm
Protection class	Class I (grounded)
Display	Actual value indication via LEDs
Housing protection	IP66 in acc. to IEC 60529
Housing material	aluminium casting, coated
Dimension / weight	L \times W \times H = 177 \times 107 \times 66 mm / ~ 950 g
Ambient temperature/-humidity	- 20...+ 50 $^{\circ}$ C / 0...95 % rH, non condensed
Maintenance	maintenance free, nevertheless maintenance must be complied with regional standards, rules and regulations
Sensor circuit	circuit (data see tables)
Start delay	5 sec.
Starting bypass time (AUB)	120 sec. (fix)
Output switch	potential free switching contact
Ratings load max.	0,5 A @ 30 VAC/DC / 0,1 A @ 250 VAC / 0,1 A @ 220 VDC
Ratings load min.	10 mW / 0,1 V / 1 mA
Mechanical life	10 \times 10 ⁶
Electrical life (rated load)	100 \times 10 ³
Wiring diagram (SB)	SB 1.0, SB 2.0, SB 3.0, SB 4.0
Installation sensor / tubing	in safe area

Technical data	plug
Electrical connection	Terminal max. 0,75 mm ² , wiring acc. to diagram (terminal 2, 3)
Cable gland	PG7, diameter ~ \varnothing 6...8 mm

Explosion proof	InBin-A...
CE-Mark	CE
EMC directive	RL 89/336/EC
Low voltage directive	RL 73/23/EC
Protection type	IP 66 in acc. to EN 60529
Elect. safety	Protection class I (grounded), Over voltage category II acc. to. EN 61010-1

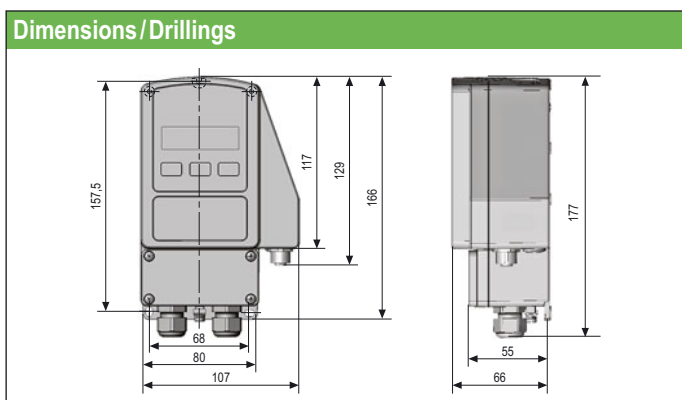

Accessories	
MKR	Mounting bracket for round ducts up to \varnothing 600 mm

Electrical connection

InBin-A... transducers are equipped with a 24 VAC/DC power supply. The supply has to be connected at terminal 1 (-/-) and 2 (+/+). The electrical wiring must be realized via integrated junction box. The starting bypass delay can be activated by a short circuit of terminal 2 and terminal 3 (AUB1) or terminal 2 and terminal 4 (AUB2). An active bypass delay is indicated with green blinking LEDs.

Attention: Do not open covers when circuits alive!

Connect the wires max. 0,75 mm² acc. to wiring diagram. After than close thread tighten The cable diameter has to be between 6-8 mm.

Connectable sensors are:

TBR-2... / TBK... / TBT... thermostats, FBR-2G / FBK-2G humiditytstats DBK... differential pressure switches, WFBK-2G airflow switch TBK-FR-2G frost protection thermostats

Wiring probe output at InBin-A transducer

Terminals

SB 4.0

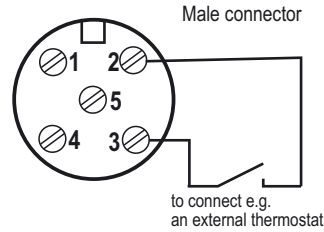

Values intrinsically safe (IS) for passive sensors

- U < 10 V
- I < 10 mA
- P < 20 mW

Open the plug, connect the wires. Use terminal acc. to diagram, close tighten. Unused connectors must be covered by a protective cap against damage and dirt

Wiring Diagram InBin-A (terminal box)

InBin-A1	SB 1.0	Head/Button side of InBin-A1
<p>24 VAC/DC - + ~ ~ PE</p> <p>Relay output 250VAC 0,1A / 220VDC 0,1A 30 VAC/DC, 0,5 A</p> <p>If supply voltage 24 VAC/DC different from the relay voltage must be used different cables or double isolated.</p> <p>function like connected sensor</p>	<p>Head/Button side of InBin-A1</p> <p>Connector 1 for output of sensor 1</p>	
<p>24 VAC/DC - + ~ ~ PE</p> <p>Relay output 250VAC 0,1A / 220VDC 0,1A 30 VAC/DC, 0,5 A</p> <p>If supply voltage 24 VAC/DC different from the relay voltage must be used different cables or double isolated.</p> <p>function like connected sensor</p>	<p>Head/Button side of InBin-A2</p> <p>Connector 1 for output of sensor 1</p>	
<p>24 VAC/DC - + ~ ~ PE</p> <p>Relay output 250VAC 0,1A / 220VDC 0,1A 30 VAC/DC, 0,5 A</p> <p>If supply voltage 24 VAC/DC different from the relay voltage must be used different cables or double isolated.</p> <p>function like connected sensor</p>	<p>Head/Button side of InBin-A5</p> <p>Connector 1 for output of sensor 1</p>	

Display

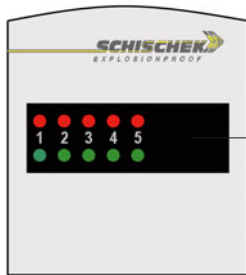

Display for state indication

Important information for installation and operation

Installation, Commissioning, Maintenance

The cable has to be drawn through the cable gland. After electrical connection the cable gland must be fixed tight. IP66 must be fulfilled. In acc. with operation InBin switches are maintenance free. Nevertheless maintenance must comply with regional standards, rules and regulations. The sensors must not be opened by the customer. For outdoor installation a protective housing against rain, snow and sun should be applied. For electrical connection use the internal junction box.

Attention: Note the national rules before opening the internal junction box. Cut off the power supply.

A. Supply and Contact

Wires from safety extra low voltage must be separated from others. Only at 24 VAC/DC is supply and signal wires in one cable permitted. All others use separate or double isolated cables. Install overload protection fuse < 10 A.

B. Long cabling

For using long signal wires, shielded cables are recommended. The shield must be connected to the InBin-... switch inside the terminal box.

C. Separate ground wires

Use for supply and signal wires a separate ground.

Installation

