



RedBin-A... transducer for switching sensors

Electrical, explosion proof transducer for switching sensors
24 VAC/DC supply voltage, output potential free switching contact
PTB-certified in acc. with ATEX directive 94/9/EC for zone 2, 22

RedBin - A1
RedBin - A2
RedBin - A5

Subject to change!

Compact . Easy installation . Universal . Cost effective . Safe

Type	Channel	Supply	Output switch	Max. ratings	Wiring
RedBin - A1	1 ×	24 VAC/DC	pot. free contact	250 V, 0.1A / 30 V, 0.5 A	SB 1.0 / SB 4.0
RedBin - A2	2 ×	24 VAC/DC	pot. free contact	250 V, 0.1A / 30 V, 0.5 A	SB 2.0 / SB 4.0
RedBin - A5	5 ×	24 VAC/DC	pot. free contact	250 V, 0.1A / 30 V, 0.5 A	SB 3.0 / SB 4.0

Product views / Application

RedBin-A1



RedBin-A2



RedBin-A5

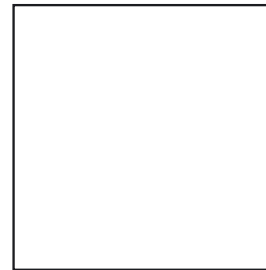

Description

The new **RedBin-A...** transducer generation (available in 1-,2- and 5-channel version) is a revolution for switching sensors in HVAC systems, in chemical, pharmaceutical, industrial and Offshore-/Onshore plants, for use in hazardous areas zone 2 (gas) and zone 22 (dust). Highest protection class (ATEX) and IP 66 protection, small dimension, universal functions and technical data guarantee safe operation even under difficult environmental conditions.

Highlights

- ▶ For all type of gas, mixtures, vapours and dust for use in zone 2 and 22
- ▶ No additionally Ex-i module required
- ▶ Only intrinsically safe wiring/installation between transducer and sensor required
- ▶ No intrinsically safe wiring/installation and no space in the panel required
- ▶ Integrated junction box
- ▶ Power supply 24 VAC/DC
- ▶ Output potential free switching contact
- ▶ Display for switching state indication
- ▶ Fix starting bypass time for two channels
- ▶ Compact design and small dimension (L × B × H = 177 × 107 × 66 mm)
- ▶ Robust aluminium housing in protection class IP 66
- ▶ Down to -20°C ambient temperature applicable



Technical data	RedBin - A...
Power supply	24 VAC/DC \pm 20% (19,2...28,8 VAC/DC) 50...60 Hz
Current, power consumption	150 mA, ~ 4 W, internal fuse 500 mA, without bracket, not removable
Galvanic isolation	supply – output 1,5 kV
Electrical connection	terminals 0,14...2,5 mm ² at integrated junction box
Cable entry	2 x M16 x 1,5 Ex e approved, cable diameter ~ \varnothing 5...10 mm
Protection class	Class I (grounded)
Display	Actual value indication via LEDs
Housing protection	IP66 in acc. to IEC 60529
Housing material	aluminium casting, coated
Dimension / weight	L x W x H = 177 x 107 x 66 mm / ~ 950 g
Ambient temperature/-humidity	- 20...+ 50 °C / 0...95 % rH, non condensed
Maintenance	maintenance free, nevertheless maintenance must be complied with regional standards, rules and regulations
Sensor circuit	IS circuit (data see tables)
Start delay	5 sec.
Starting bypass time (AUB)	120 sec. (fix)
Output switch	potential free switching contact
Ratings load max.	0,5 A @ 30 VAC/DC / 0,1 A @ 250 VAC / 0,1 A @ 220 VDC
Ratings load min.	10 mW / 0,1 V / 1 mA
Mechanical life	10 x 10 ⁶
Electrical life (rated load)	100 x 10 ³
Wiring diagram (SB)	SB 1.0, SB 2.0, SB 3.0, SB 4.0
Installation sensor / tubing	in Ex-area zone 2, 22

Explosion proof	RedBin-A...	
Acc. to ATEX directive	PTB 09 ATEX 2018	94/9/EC (ATEX)
Approval for gas	II3(1)G Ex nC[ia] IIC T6	for zone 2
Approval for dust	II3(1)D Ex tD [iaD] A22 IP66 T80°C	for zone 22
CE-Mark	CE No. 0158	
EMC directive	RL 89/336/EC	
Low voltage directive	RL 73/23/EC	
Protection type	IP 66 in acc. to EN 60529	
Potential compensation	external PA-terminal, 4 mm ²	
Protection Class	I (grounded)	
	over voltage categorie II acc. to EN 61010-1	

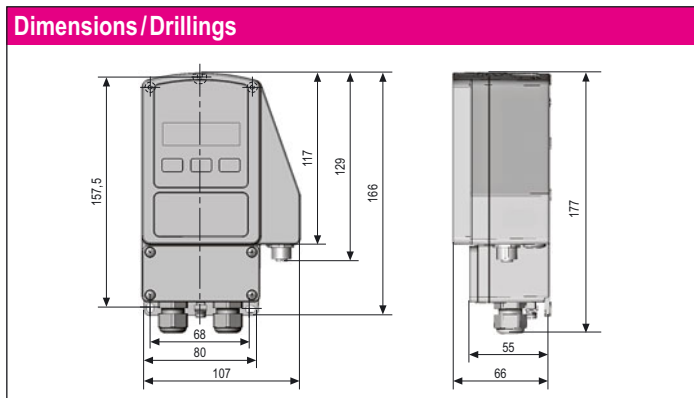

Accessories
MKR Mounting bracket for round ducts up to \varnothing 600 mm



Electrical connection

RedBin-A... transducers are equipped with a 24 VAC/DC power supply. The supply has to be connected at terminal 1 (-/~) and 2 (+/~). The electrical wiring must be realized via integrated junction box. The starting bypass delay can be activated by a short circuit of terminal 2 and terminal 3 (AUB1) or terminal 2 and terminal 4 (AUB2). An active bypass delay is indicated with green blinking LEDs.

Attention: Do not open covers when circuits alive!

Connect the wires max. 0,75 mm² are acc. to diagram. After than close threat tighten The cable diameter has to be between 6-8 mm.

Connectable sensors are:

TBR-2... / TBK... / TBT... thermostats, FBR-2G / FBK-2G humiditytstats DBK... differential pressure switches, WFBK-2G airflow switch TBK-FR-2G frost protection thermostats

Wiring Ex i output at RedBin-A transducer

Terminals

SB 4.0

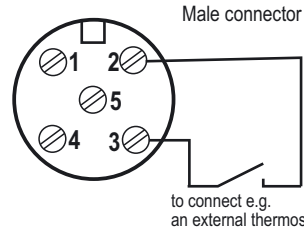

Values intrinsically safe (IS) for passive sensors

U_o = 7,14 V
I_o = 8 mA
P_o = 15 mW
C_i = 0
L_i = 0
C_o (IIC) = 5 mH
L_o (IIC) = 1,5 µF

Open the plug, connect the wires. Use terminal acc. to diagram, close tighten. Unused connectors must be covered by a protective cap against damage and dirt

Wiring Diagram RedBin-A (terminal box)

RedBin-A1

SB 1.0

Head/Button side of RedBin-A1

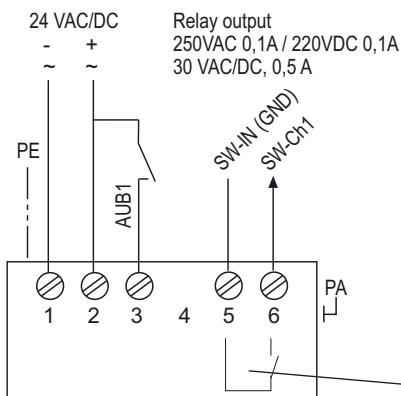

Relay output
250VAC 0,1A / 220VDC 0,1A
30 VAC/DC, 0,5 A

If supply voltage 24 VAC/DC different from the relay voltage must be used different cables or double isolated.

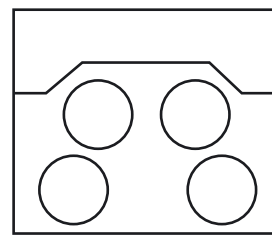

Connector 1 for output of sensor 1



RedBin-A2

SB 2.0

Head/Button side of RedBin-A2

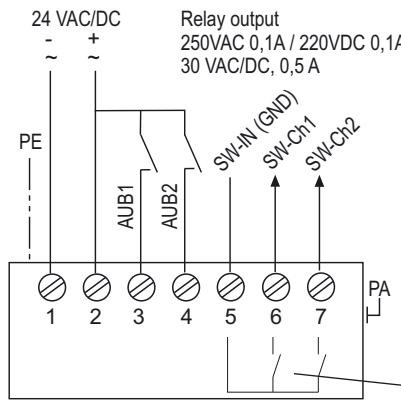

Relay output
250VAC 0,1A / 220VDC 0,1A
30 VAC/DC, 0,5 A

If supply voltage 24 VAC/DC different from the relay voltage must be used different cables or double isolated.

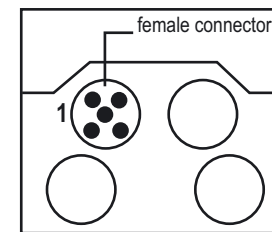

Connector 1 for output of sensor 1



RedBin-A5

SB 3.0

Head/Button side of RedBin-A5

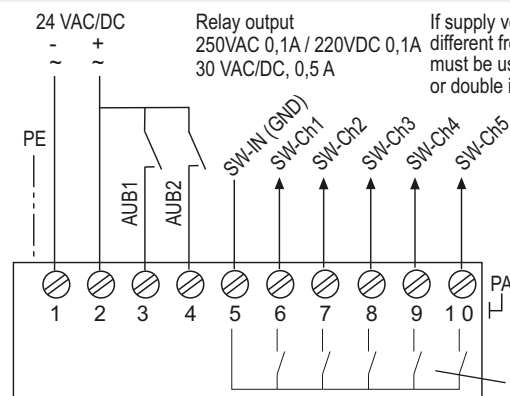

Relay output
250VAC 0,1A / 220VDC 0,1A
30 VAC/DC, 0,5 A

If supply voltage 24 VAC/DC different from the relay voltage must be used different cables or double isolated.

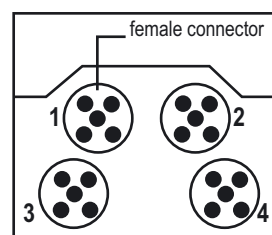

Connector 1 for output of sensor 1





Display

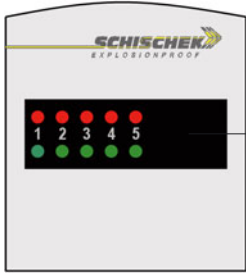

Display for state indication

Important information for installation and operation

Installation, Commissioning, Maintenance

The cable has to be drawn through the cable gland. After electrical connection the cable gland must be fixed tight. IP66 must be fulfilled. In acc. with operation RedBin switches are maintenance free. Nevertheless maintenance must comply with regional standards, rules and regulations. The sensors must not be opened by the customer. For outdoor installation a protective housing against rain, snow and sun should be applied. For electrical connection use the internal approved Ex-e junction box.

Attention: Note the explosion proof rules before opening the internal junction box. Cut off the power supply.

A. Supply and Contact

Wires from safety extra low voltage must be separated from others. Only at 24 VAC/DC is supply and signal wires in one cable permitted. All others use separate or double isolated cables. Install overload protection fuse < 10 A.

B. Long cabling

For using long signal wires, shielded cables are recommended. The shield must be connected to the RedBin-... switch inside the terminal box.

C. Separate ground wires

Use for supply and signal wires a separate ground.

Installation

Ex area
Zone 2, 22



safe area



Relay output	250VAC 0,1A 220VDC 0,1A 30 VAC/DC / 0,5 A
--------------	---

Supply	24 V AC/DC ± 20%
--------	------------------

- Do not open covers when circuits alive
- The cable must be installed in a fixed position and protected against mechanical and thermal damage.
- Connect protection earth
- Avoid thermal transfer from sensor to transducer (ensure max ambient temperature !)
- Ambient temperature -20...+50 °C @ T6
- Close all covers, entries with min IP66
- All transducers are maintenance free.
- Nevertheless maintenance must comply with regional standards, rules and regulations.
- Close after settings all covers and cable entries tight min. IP66.
- For outdoor installation a protective housing against rain, snow and sun should be applied
- For electrical connection use the integrated junction box.