



# RedBin-N... Fan belt monitoring via speed control switch up to 10.000 min<sup>-1</sup>

RedBin - N  
RedBin - N - 2

Subject to change!

Electrical, explosion proof fan belt switch  
24 VAC/DC supply voltage, output potential free switching contact  
PTB-certified in acc. with ATEX directive 94/9/EC for zone 2, 22

## Compact . Easy installation . Universal . Cost effective . Safe

Type	Sensor	Supply	Range	Min. setting	Output switch	Max. ratings	Wiring
RedBin - N	Namur DIN19234	24 VAC/DC	0..10,000 min <sup>-1</sup>	50 min <sup>-1</sup>	pot. free contact	250 VAC, 0.1A / 30 V, 0.5 A	SB 1.0 / SB 2.0
RedBin - N - 2	as above, but with second switching output				2 pot. free contacts	250 VAC, 0.1A / 30 V, 0.5 A	SB 1.0 / SB 2.0

### Application

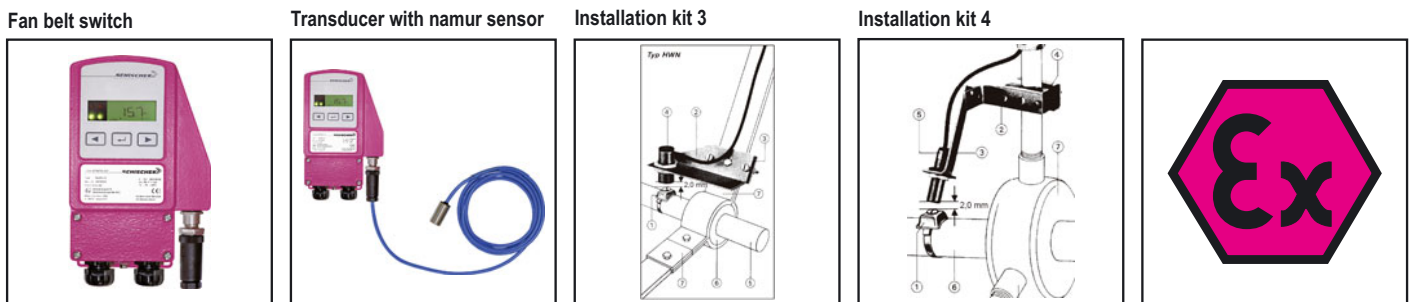

### Description

The new **RedBin-N** speed control switch generation up to 10,000 min<sup>-1</sup> is a revolution for fan belt monitor transducers in HVAC systems, in chemical, pharmaceutical, industrial and Offshore-/Onshore plants, for use in hazardous areas zone 2 (gas) and zone 22 (dust). Highest protection class (ATEX) and IP 66 protection, small dimension, universal functions and technical data guarantee safe operation even under difficult environmental conditions.

The switching points are scalable within the maximum ranges. The integrated display is for actual value indication which can be switched off. All sensors are programmable on site without any additional tools. **RedBin-N-2** sensors are additionally equipped with a secondary switching output, which can be parameterized independently.

### Highlights

- ▶ For all type of gas, mixtures, vapours and dust for use in zone 2 and 22
- ▶ No additionally Ex-i module required
- ▶ No intrinsically safe wiring/installation between panel and sensor required
- ▶ No intrinsically safe wiring/installation and no space in the panel required
- ▶ Integrated junction box
- ▶ Power supply 24 VAC/DC
- ▶ Output potential free switching contact
- ▶ Display with backlight, can be switched off
- ▶ Scalable switching characteristics
- ▶ Scalable starting bypass time
- ▶ Compact design and small dimension (L × B × H = 177 × 107 × 66 mm)
- ▶ Robust aluminium housing in protection class IP 66
- ▶ Down to -20°C ambient temperature applicable
- ▶ Password locking
- ▶ Optional second switching output



Technical data	RedBin - N...
Power supply	24 VAC/DC $\pm$ 20% (19,2...28,8 VAC/DC) 50...60 Hz
Current, power consumption	150 mA, ~ 4 W, internal fuse 500 mA, without bracket, not removable
Galvanic isolation	supply – output 1,5 kV
Electrical connection	terminals 0,14...2,5 mm <sup>2</sup> at integrated junction box
Cable entry	2 x M16 x 1,5 Ex-e approved, cable diameter ~ $\varnothing$ 5...10 mm
Protection class	Class I (grounded)
Display	LCD with backlight, display for configuration, user guidance, parameter and actual value indication via LEDs
Control elements	3 buttons for configuration
Housing protection	IP66 in acc. to IEC 60529
Housing material	aluminium casting, coated
Dimension / weight	L x W x H = 177 x 107 x 66 mm / ~ 950 g
Ambient temperature/-humidity	- 20...+ 50 °C / 0...95 % rH, non condensed
Storage temperature	- 20...+ 70 °C
Measuring range	0...10.000 min <sup>-1</sup>
Range scalable on site	50 min <sup>-1</sup> ...10.000 min <sup>-1</sup>
Maintenance	maintenance free, nevertheless maintenance must be complied with regional standards, rules and regulations
Sensor circuit	internal IS circuit
Sensor	Namur, DIN 19234
Response time of sensor	T90 / 5 sec.
Accuracy of rotary speed	$\pm$ 0,5 % of end value
Setting range hysteresis	25 min <sup>-1</sup> ...1000 min <sup>-1</sup> (factory setting 50 min <sup>-1</sup> )
Start delay	5 sec.
Starting bypass time	3...240 sec. (via menu adjustable; preset 120 sec.)
Output switch	potential free switching contact
Ratings load max.	0,5 A @ 24 VAC/DC / 0,1 A @ 250 VAC / 0,1 A @ 220 VDC
Ratings load min.	10 mW / 0,1 V / 1 mA
Mechanical life	10 x 10 <sup>6</sup>
Electrical life (rated load)	100 x 10 <sup>3</sup>
Wiring diagram (SB)	SB 1.0 / SB 2.0
Installation sensor / tubing	in Ex-area zone 2, 22

Explosion proof	RedBin-N...	
acc. to ATEX directive	PTB 2009 ATEX 2018	94/9/EC (ATEX)
Approval for gas	II3(1)G Ex nC[ia] IIC T6	for zone 2
Approval for dust	II3(1)D Ex tD A22 [iaD] IP66 T80°C	for zone 22
CE-Mark	CE No. 0158	
EMC directive	RL 89/336/EC	
Low voltage directive	RL 73/23/EC	
Protection type	IP 66 in acc. to EN 60529	
Potential compensation	external PA-terminal, 4 mm <sup>2</sup>	
Protection Class	I (grounded)	
	over voltage categorie II acc. to EN 61010-1	

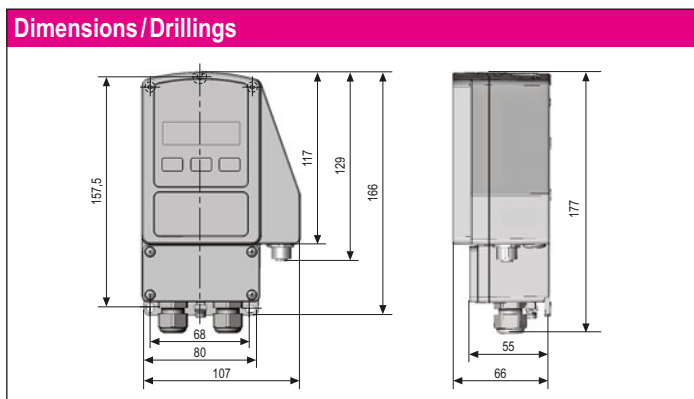

Accessories	
Installation kit 3	Mounting set for Namur sensor onto ventilators up to 20.000 m <sup>3</sup> /h
Installation kit 4	Mounting set for Namur sensor onto ventilators over 20.000 m <sup>3</sup> /h
MKR	Mounting bracket for round ducts up to $\varnothing$ 600 mm



Electrical connection

RedBin-N... switches are equipped with a 24 VAC/DC power supply. The supply has to be connected at terminal 1 (-/-) and 2 (+/-). The electrical wiring must be realized via integrated junction box.

If supply voltage 24 VAC/DC different from the relay voltage must be used different or double isolated cables. The starting bypass delay can be activated by a short circuit of terminal 2 and terminal 3 (AUB). An active bypass delay is indicated with green blinking LEDs.

Attention: Do not open covers when circuits alive!

Wiring Diagram RedBin-N / RedBin-N-S2

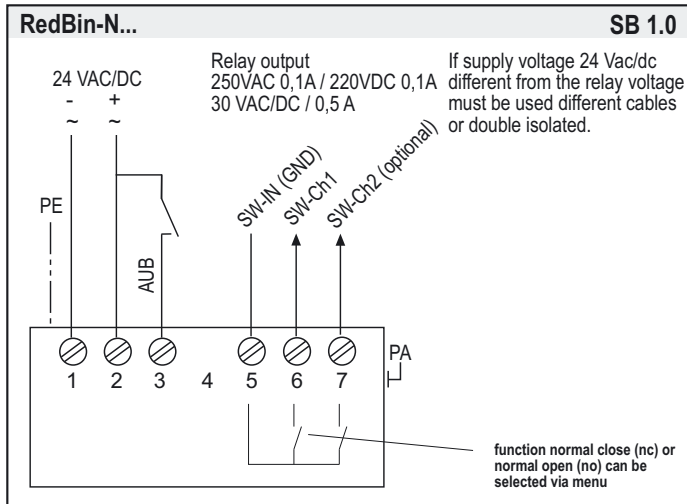

Installation

Ex area Zone 2, 22



safe area

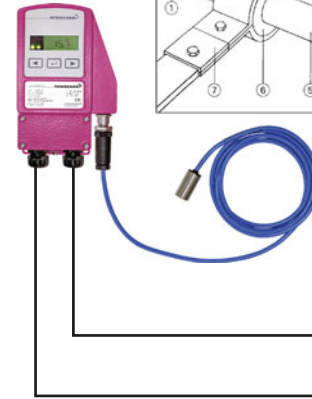
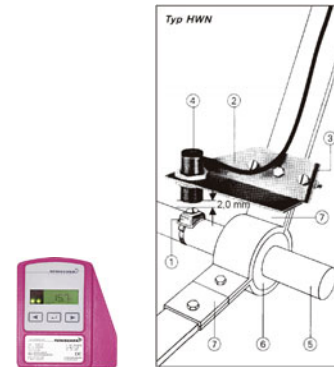

Relay output 250V 0,1A / 30 V / 0,5 A
Supply 24 V AC/DC +/- 20%

- Do not open covers when circuits alive
- The cable must be installed in a fixed position and protected against mechanical and thermal damage.
- Connect protection earth
- Avoid thermal transfer from sensor to transducer (ensure max ambient temperature !)
- Ambient temperature -20...+50 °C @ T6
- Close all covers, entries with min IP66
- All transducers are maintenance free.
- Nevertheless maintenance must comply with regional standards, rules and regulations.
- Close after settings all covers and cable entries tight min. IP66.
- For outdoor installation a protective housing against rain, snow and sun should be applied
- For electrical connection use the integrated junction box.

Namur sensor connector

SB 2.0

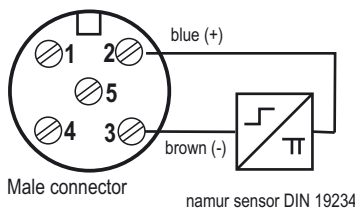

Values intrinsically safe (IS) for passive sensors

Uo = 9,6 V
Io = 9,7 mA
Po = 24 mW
Ci = 0 Li = 0
Co (IIC) = 840 nF
Lo (IIC) = 5 mH

Display and Buttons

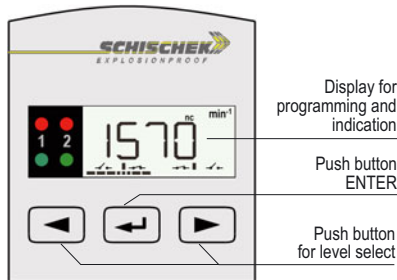

Change operation-/parametrisation mode

To change from operation to parametrisation mode push the enter button for minimum 3 seconds. Back over the menu save.

Indication of data logging

The blinking unit in the display shows that datas received and the device is working.

Password input

The default / delivery setup is 0000. In this configuration the password input is not activated. To activate a password change the 4 digits into your chosen numbers (e.g. 1234) and press Enter.

Please keep your password in mind for next parameter change!

Due to a new parameter setup the password is requested.

Important information for installation and operation

Installation, Commissioning, Maintenance

The cable has to be drawn through the cable gland. After electrical connection the cable gland must be fixed tighten. IP66 must be fulfilled. In acc. with operation RedBin switches are maintenance free. Nevertheless maintenance must comply with regional standards, rules and regulations. The sensors must not be opened by the customer. For outdoor installation a protective housing against rain, snow and sun should be applied. For electrical connection use the internal junction box.

Attention: Note the explosion proof rules before opening the internal junction box. Cut off the power supply.

A. Supply and Contact

Wires from safety extra low voltage must be separated from others. Only at 24 VAC/DC is supply and signal wires in one cable permitted. All others use separate or double isolated cables. Install overload protection fuse < 10 A.

B. Long cabling

For using long signal wires, shielded cables are recommended. The shield must be connected to the RedBin-P switch inside the terminal box.

C. Separate ground wires

Use for supply and signal wires a separate ground.



Parametrisation and commissioning of RedBin-N transducers

Preparation of parametrisation/operation

Operation ↔ Parametrisation, push for 3 sec.

If password (PW) protection is active: put PW in, push



Change operation- / parametrisation mode

To change from operation to parametrisation mode push „enter button“ for minimum 3 seconds. Back over the menu save.

Menu	Function	Enter	Indication	Select	Enter	Next indication	Next selction	Enter	Next menu
Menu 1	no function - menu skip								
Menu 2	no function - menu skip								
Menu 3	set 1 select switching point 1		Menu 3 700 min <sup>-1</sup>			SEt 1	adjust set 1		
Menu 4	set 2* select switching point 2		Menu 4 1500 min <sup>-1</sup>			SEt 2	adjust set 2		
Menu 5	hysteresis** select hysteresis		Menu 5 100 min <sup>-1</sup>			HYSt	adjust hysteresis		
Menu 6	mode** select switching characteristic		Menu 6 UP <sub>nc</sub>		Menu 6 nc	ModE	norm. open (no), norm. closed (nc) select normal sensor interval		
Menu 7	no function - menu skip								
Menu 8	no function - menu skip								
Menu 9	no function - menu skip								
Menu 10	no function - menu skip								
Menu 11	no function - menu skip								
Menu 12	time select time for starting bypass (AUB)		Menu 12 100 s			TIME	adjust bypass time in sec.		
Menu 13	lamp select backlight		Menu 13 ON			LAMP	on, off		
Menu 14	no function - menu skip								
Menu 15	security select password		Menu 15 0000			SECU	enter password		
Menu 16	save select save data		Menu 16 YES			SAVE	no, yes, return, default setting		

\* available for 2-stage version only (RedBin-N-2)

\*\* useable in professional mode only (see following section)

**Using the menu**

To beware complexity during the parametrisation process, the RedBin-N has a predefined setup for the hysteresis (menu 5) and the operation mode (menu 6):

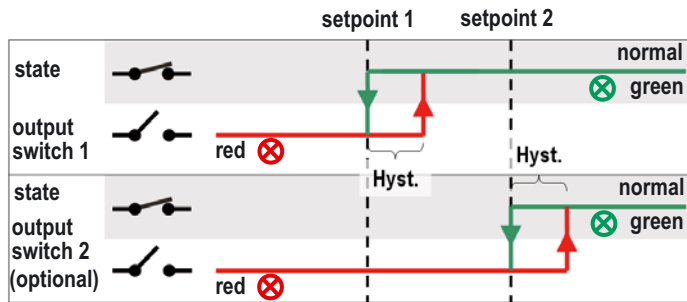

Menu 5 and Menu 6 will normally skipped during the parametrisation process.

**Professional mode**

If the user wants to change the factory setting for hysteresis and the operation mode, press the „right“-button for more than 3 seconds. (Make sure that the main-menu is selected - the arrows next to the „MENU“-icon must be visible) Now „Professional“-mode will be active and two further menus were added: menu 5 „hysteresis“ and menu 6 „mode“.

**Using the menu 6 „mode“**

First of all the user has to define the device normal range. For example:

- The device should indicate (green LED) if the fan speed is under the setpoints, mode „down-range“ has to be selected. With other words: the measure value is normally under the setpoints.
- The device should indicate (green LED) if the fan speed is over the setpoints, mode „up-range“ has to be selected. (The measure value is normally over the setpoints.)
- The device should indicate (green LED) if the fan speed is between the setpoints, mode „mid-range“ has to be selected. (The measure value is normally between the setpoints.) This mode is only for 2-stage devices available (RedBin-N-2).

In the second step the switching characteristic of the output relay has to be selected:

- „normally closed“ (nc): if the measure value is in the normal range (see above), the corresponding relays were closed.
- „normally open“ (no): if the measure value is in the normal range (see above), the corresponding relays were open.

You'll find a detailed description of all possible settings in the following section.

**Switching characteristic „up-range“ – „normally closed“**

„Up-range“: the normal range is above setpoint 1 and setpoint 2

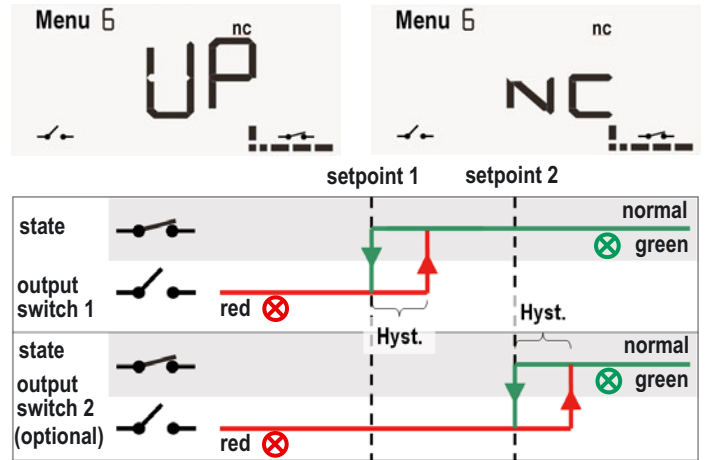

**Switching characteristic „up-range“ – „normally open“**

„Up-range“: the normal range is above setpoint 1 and setpoint 2

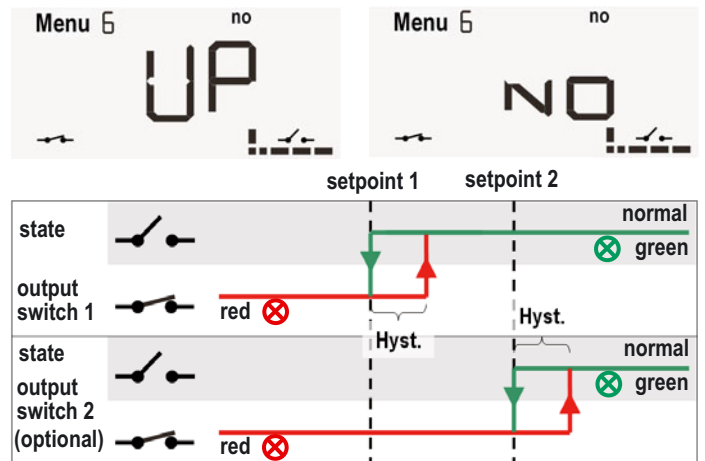

**Switching characteristic „mid-range“ – „normally closed“**

„Mid-range“: the normal range is between setpoint 1 and setpoint 2 (for 2-stage devices only)

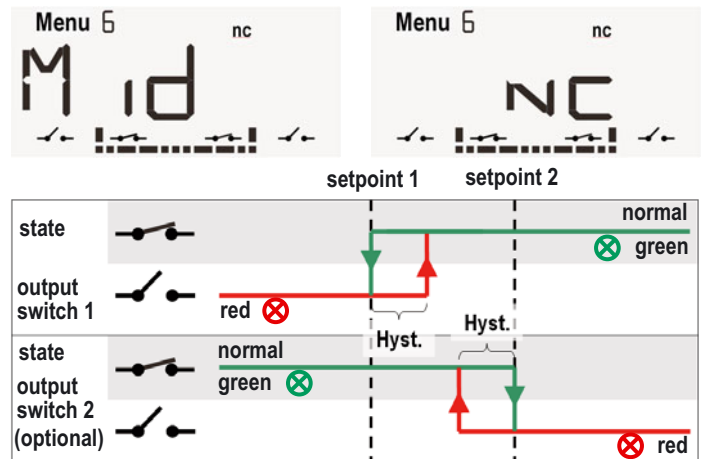



Switching characteristic „mid-range“ – „normally open“

„Mid-range“: the normal range is between setpoint 1 and setpoint 2 (for 2-stage devices only)

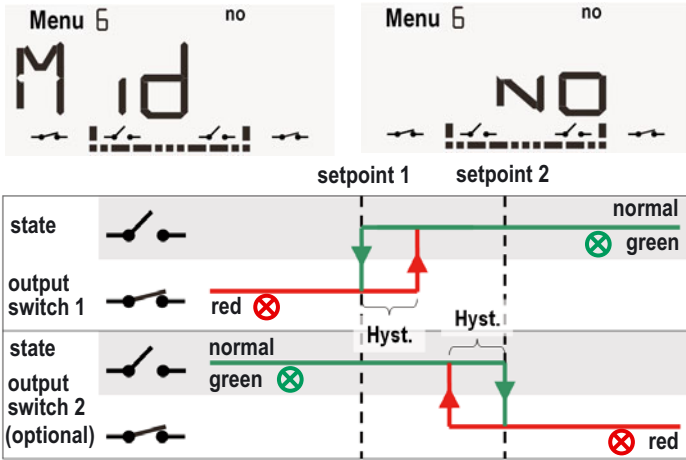

Switching characteristic „down-range“ – „normally closed“

„Mid-range“: the normal range is under setpoint 1 and setpoint 2

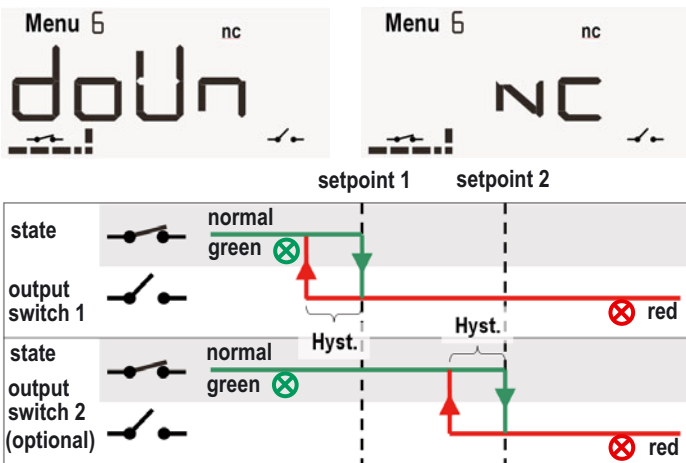

Switching characteristic „down-range“ – „normally closed“

„Mid-range“: the normal range is under setpoint 1 and setpoint 2

