

# **SCHISCHEK**

A **rotork** Brand



## Rotary drives

Translation of the original installation guide

Version 5 · 2023-04-13

Schischek GmbH  
Mühlsteig 45, Gewerbegebiet Süd 5  
90579 Langenzenn  
Germany  
Tel: +49 9101 9081-0  
Fax: +49 9101 9081-77  
Email: [info-de@schischek.com](mailto:info-de@schischek.com)

## Contents

1	About these instructions .....	8
2	Safety .....	9
2.1	Warnings .....	9
2.1.1	Structure of the warnings .....	9
2.1.2	Meaning of the signal words and symbols .....	10
2.2	Applicable directives .....	11
3	Device description .....	12
3.1	Intended use .....	12
3.2	Foreseeable misuse .....	14
3.3	Type name .....	15
3.4	Housing options .....	16
3.5	Special versions .....	17
3.6	Function / performance characteristics .....	19
3.7	Electrical connections .....	19
3.7.1	3-point no spring return .....	20
3.7.2	3-point with spring return with configurable spring return period ....	20
3.7.3	1-wire with spring return with configurable spring return period .....	21
3.7.4	3-point with spring return constant spring return period .....	21
3.7.5	1-wire with spring return constant spring return period .....	22
3.7.6	2-wire with spring return constant spring return period .....	22
3.7.7	1-wire with spring return constant spring return period .....	23
3.7.8	Integrated limit switch .....	23
3.7.9	Integrated limit switch .....	24
3.7.10	3-point with spring return constant spring return period continuous	24
3.7.11	1-wire with spring return with constant spring return period continuous .....	25
3.7.12	3-point with spring return with configurable spring return period continuous .....	25
3.7.13	1-wire with spring return with configurable spring return period continuous .....	26
3.7.14	1-wire with spring return continuous without feedback signal .....	26

---

3.7.15	3-point with spring return with configurable spring return period continuous feedback signal .....	27
3.7.16	Without spring return continuous activation .....	27
3.7.17	1-wire with spring return continuous activation .....	28
3.7.18	1-wire with spring return with configurable spring return period BF ..	28
3.7.19	3-point with spring return with configurable spring return period BF	29
3.7.20	1-wire with spring return with constant spring return period BF .....	29
3.7.21	3-point with spring return with constant spring return period BF .....	30
3.7.22	1-wire with spring return constant spring return period BF1/BF3 .....	30
3.8	Power consumption as a function of supply voltage .....	31
3.9	Wire cross-sections for the supply .....	32
3.10	Technical data .....	33
3.10.1	Note on nominal values .....	33
3.10.2	Max-5.10, Max-5.10-CTS, Max-5.10-VAS .....	34
3.10.3	Max-5.10-Y, Max-5.10-Y-CTS, Max-5.10-Y-VAS .....	36
3.10.4	Max-5.10-S, Max-5.10-S-CTS, Max-5.10-S-VAS .....	39
3.10.5	Max-5.10-F, Max-5.10-F-CTS, Max-5.10-F-VAS .....	42
3.10.6	Max-5.10-SF, Max-5.10-SF-CTS, Max-5.10-SF-VAS .....	44
3.10.7	Max-5.10-YF, Max-5.10-YF-CTS, Max-5.10-YF-VAS .....	47
3.10.8	Max-5.10-BF, Max-5.10-BF-CTS, Max-5.10-BF-VAS .....	50
3.10.9	Max-5.10-R, Max-5.10-R-CTS, Max-5.10-R-VAS .....	53
3.10.10	Max-5.10-CY, Max-5.10-CY-CTS, Max-5.10-CY-VAS .....	55
3.10.11	Max-5.10-CYF, Max-5.10-CYF-VAS .....	58
3.10.12	Max-15-F1, Max-15-F1-CTS, Max-15-F1-VAS .....	60
3.10.13	Max-15-F, Max-15-F-CTS, Max-15-F-VAS .....	62
3.10.14	Max-15-SF, Max-15-SF-CTS, Max-15-SF-VAS .....	64
3.10.15	Max-15-SF1, Max-15-SF1-CTS, Max-15-SF1-VAS .....	67
3.10.16	Max-15-YF, Max-15-YF-CTS, Max-15-YF-VAS .....	70
3.10.17	Max-15-BF1, Max-15-BF1-CTS, Max-15-BF1-VAS .....	73
3.10.18	Max-15-BF, Max-15-BF-CTS, Max-15-BF-VAS .....	76
3.10.19	Max-15-BF-TR .....	79
3.10.20	Max-15-CYF, Max-15-CYF-VAS .....	82



---

3.10.21	Max-15.30, Max-15.30-CTS, Max-15.30-VAS .....	84
3.10.22	Max-15.30-Y, Max-15.30-Y-CTS, Max-15.30-Y-VAS .....	86
3.10.23	Max-15.30-S, Max-15.30-S-CTS, Max-15.30-S-VAS .....	89
3.10.24	Max-15.30-R, Max-15.30-R-CTS, Max-15.30-R-VAS .....	92
3.10.25	Max-15.30-CY .....	94
3.10.26	Max-8-F1, Max-8-F1-CTS, Max-8-F1-VAS .....	96
3.10.27	Max-8-SF1, Max-8-SF1-CTS, Max-8-SF1-VAS .....	98
3.10.28	Max-8-BF1, Max-8-BF1-CTS, Max-8-BF1-VAS .....	101
3.10.29	Max-30-BF, Max-30-BF-CTM .....	104
3.10.30	Max-30-BF3, Max-30-BF3-CTM .....	107
3.10.31	Max-30-F, Max-30-F-CTM .....	110
3.10.32	Max-30-F3, Max-30-F3-CTM, Max-30-F3-VAM .....	112
3.10.33	Max-30-SF, Max-30-SF-CTM, Max-30-SF-VAM .....	114
3.10.34	Max-30-SF3, Max-30-SF3-CTM, Max-30-SF3-VAM .....	117
3.10.35	Max-30-YF, Max-30-YF-CTM, Max-30-YF-VAM .....	120
3.10.36	Max-50-BF, Max-50-BF-CTM .....	123
3.10.37	Max-50-BF3, Max-50-BF3-CTM .....	126
3.10.38	Max-50-F, Max-50-F-CTM .....	129
3.10.39	Max-50-F3, Max-50-F3-CTM .....	131
3.10.40	Max-50-SF, Max-50-SF-CTM, Max-50-SF-VAM .....	133
3.10.41	Max-50-SF3, Max-50-SF3-CTM, Max-50-SF3-VAM .....	136
3.10.42	Max-50-YF, Max-50-YF-CTM .....	139
3.10.43	Max-60-BF .....	142
3.10.44	Max-60-F, Max-60-F-CTM .....	144
3.10.45	Max-60-SF, Max-60-SF-CTM .....	146
3.10.46	Max-50.75, Max-50.75-CTM, Max-50.75-VAM .....	149
3.10.47	Max-50.75-S, Max-50.75-S-CTM .....	151
3.10.48	Max-50.75-Y, Max-50.75-Y-CTM .....	154
3.10.49	Max-100, Max-100-CTM .....	157
3.10.50	Max-100-S, Max-100-S-CTM .....	159
3.10.51	Max-100-Y, Max-100-Y-CTM .....	162
3.10.52	Max-150, Max-150-CTM, Max-150-VAM .....	165

---

3.10.53	Max-150-S, Max-150-S-CTM, Max-150-S-VAM .....	167
3.11	Accessories .....	170
<b>4</b>	<b>Transportation and storage .....</b>	<b>171</b>
4.1	Transportation .....	171
4.2	Packaging .....	171
4.3	Storage .....	171
<b>5</b>	<b>Installation and commissioning .....</b>	<b>172</b>
5.1	Axle connection .....	177
5.2	Preparing for installation .....	178
5.3	Parameter setting .....	179
5.4	Installation on air dampers (interlocking axle connection) .....	182
5.5	Installation on air dampers (friction-locked axle connection) .....	184
5.6	Installation on fire dampers .....	185
5.7	Installation on ball cocks and throttle valves .....	186
5.8	Installation of terminal boxes ... box on drive by means of installation bracket MKK-S (accessory) .....	186
5.9	Installation of auxiliary switch ... switch on the drive unit .....	188
5.10	Installation outside .....	188

---

<b>6</b>	<b>Operation</b>	<b>189</b>
6.1	Operating modes	193
6.1.1	Manual operation	193
6.1.2	Operation with 3-second motor run time	193
6.1.3	3-point standard operation	194
6.1.4	Spring-return function	194
6.1.5	Use at ambient temperatures below -20 °C	195
6.1.6	Excessive temperatures	195
6.1.7	Synchronous operation	195
6.1.8	Mechanical protection (only F1/F3 types)	195
6.1.9	Power outage	195
<b>7</b>	<b>Maintenance</b>	<b>196</b>
<b>8</b>	<b>Troubleshooting</b>	<b>198</b>
<b>9</b>	<b>Uninstalling, decommissioning, disposal</b>	<b>205</b>
<b>10</b>	<b>EU declaration of incorporation as set out in the EC Machinery Directive 2006/42/EC, Annex II B Rotary Drives ExMax, RedMax, InMax</b>	<b>207</b>
<b>11</b>	<b>EU Declaration of Conformity ExMax-..., ExMax...CT...</b>	<b>209</b>
<b>12</b>	<b>EU Declaration of Conformity RedMax-...; RedMax...-CT</b>	<b>211</b>
<b>13</b>	<b>EU Declaration of Conformity InMax-...</b>	<b>213</b>

# 1 About these instructions

This installation guide describes sizes S and M of the rotary drive for different applications:

- **InMax** model: normal industrial applications
- **RedMax** model: for Zones 2 and 22 (according to ATEX)
- **ExMax** model: for Zones 1, 2, 21 and 22 (according to ATEX)

These installation instructions describe the installation and ensure safe operation. Personnel must be familiar with the installation instructions because insufficient knowledge of its contents can have profound consequences.

Disregard or insufficient knowledge of the installation instructions can result in serious injury, irreparable damage to property, or impaired performance.

No liability is accepted for damage caused by insufficient knowledge of the installation instructions.

The original version of these installation instructions is in German. The installation instructions in other languages are translations of the original.

## 2 Safety

### 2.1 Warnings

#### 2.1.1 Structure of the warnings

All warnings in this document are structured as follows:

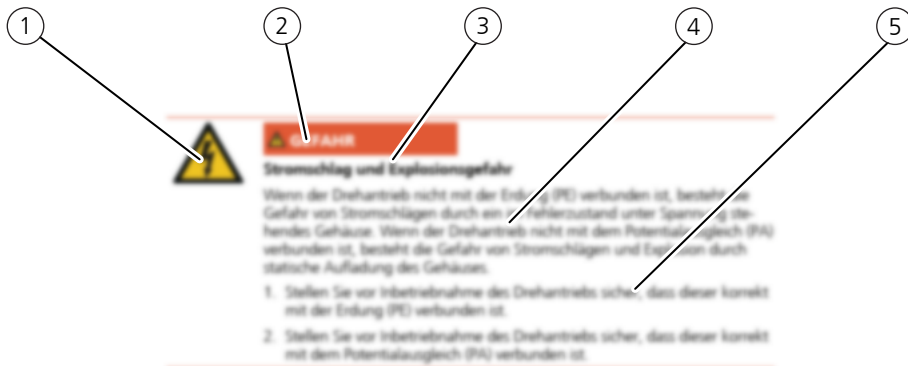

1	Hazard-specific symbol
2	Signal word
3	Type and source of the danger
4	Possible consequences of failure to observe
5	Approach to avoid danger

## 2.1.2 Meaning of the signal words and symbols

The following signal words are used in this document:

Signal word	Meaning, consequences if not avoided
DANGER	Indicates a dangerous situation, resulting in death or serious injury.
WARNING	Indicates a potentially dangerous situation, which could result in death or serious injury.
CAUTION	Indicates a potentially dangerous situation, which could result in minor injury.
NOTE	Indicates a potentially dangerous situation, which could result in damage to property or the environment.

The following hazard symbols are used in this document:

Symbol	Meaning
	General warning of a hazard
	Warning: electricity
	Warning: explosive material
	Warning: floor level obstacle
	Warning: overhead obstacles
	Warning: crushing of hands
	Warning: entanglement hazard

## 2.2 Applicable directives

### InMax model

Directive	
CE marking	CE
EMC directive	2014/30/EU
Low-voltage directive	2014/35/EU
RoHS	2011/65/EU

### RedMax model

Directive	
CE marking	CE
EMC directive	2014/30/EU
ATEX directive	2014/34/EU
Low-voltage directive	2014/35/EU
RoHS	2011/65/EU
EU type examination	EPS 18 ATEX 1 216 X
IECEx conformity	IECEx EPS 20.0027 X
Gas markings	II 3 (3) G Ex db [ic Gc] IIC T6, T5 Gc
Labelling of gases (...-CTS/CTM)	II 3 (3) G Ex db [ic Gc] IIB T6, T5 Gc
Dust markings	II 3 (3) D Ex tc [ic Dc] IIIC T80°C, T95°C Dc
Mechanical ex-protection	Ex h IIC T6/T5/T4 Gc Ex h IIIC T80°C/T95°C/T130°C Dc

### ExMax model

Directive	
CE marking	CE 0158
EMC directive	2014/30/EU
ATEX directive	2014/34/EU
Low-voltage directive	2014/35/EU
RoHS	2011/65/EU
EU type examination	EPS 17 ATEX 1 132 X
IECEx conformity	IECEx EPS 20.0027 X

Directive	
Gas markings	II 2 (2) G Ex db [ib Gb] IIC T6, T5 Gb
Labelling of gases (...CTS/CTM)	II 2 (2) G Ex db [ib Gb] IIB T6, T5 Gb
Dust markings	II 2 (2) D Ex tb [ib Db] IIIC T80°C, T95°C Db
Mechanical ex-protection	Ex h IIC T6/T5/T4 Gb Ex h IIIC T80°C/T95°C/T130°C Db

## 3 Device description

### 3.1 Intended use

The **InMax** models of the rotary drive are suitable as 90° rotary drives for installation in a secure area (industrial applications with no explosion protection). The **RedMax** models of the rotary drive are suitable as electric 90° rotary drives for industrial applications with explosion protection (gas, mist, steam, dust) in areas with explosion protection (Zones 2 and 22). The **ExMax** models of the rotary drive are suitable as electric 90° rotary drives for industrial applications with explosion protection (gas, mist, steam, dust) for installation in areas with explosion protection (Zones 1, 2, 21 and 22).

Any other use is not intended and thus not permitted. Non-compliance will invalidate the warranty and any warranty claims.

Different torque ranges, models and equipment options enable different application areas:

- blind dampers
- control dampers and shut-off valves
- fire dampers
- smoke extraction flaps
- volume flow controls
- ball valves
- throttle valves

The following figure shows a typical installation situation.





Fig. 1: Example application for a rotary drive

## 3.2 Foreseeable misuse

The following list shows examples of incorrect rotary drive use:

- operating multiple drives on one shaft
- using the wrong type, insufficient power, no spring-return mechanism (despite being required), no ATEX (despite being required)
- adjusting drive even though it is live
- Allen key left in place
- sticking finger in hollow shaft
- selecting inadequate conductor cross-section for connection
- incorrect integration in the control system
- incorrect parameter setting – valve does not move into correct position, motor has insufficient torque
- working in explosive atmosphere at the drive unit
- operating with incorrect load
- runtime for the drive too high

## 3.3 Type name

The rotary drive's type name has information about its most important technical properties and application areas. The figure below shows the structure of the type name based on an example and explains the abbreviations used.

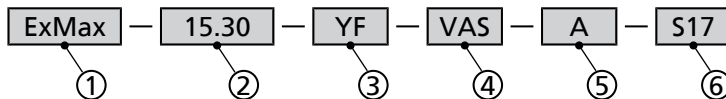

Fig. 2: Type name

1	Product name, composed of the application area (Ex, Red or In) and the name "Max" for the rotary drives
2	Torque or torque range in Nm
3	Special equipment options: <ul style="list-style-type: none"> <li>• Y: continuous version</li> <li>• S: integrated limit switch</li> <li>• F: spring return</li> <li>• BF: fire prevention design: spring return can also be triggered via the temperature sensor ..Pro-TT</li> <li>• F1: spring return within ~1 s (size S)</li> <li>• F3: spring return within ~3 s (size M)</li> </ul>
4	Housing options <ul style="list-style-type: none"> <li>• Not specified: aluminium</li> <li>• VAS: stainless steel (size S)</li> <li>• CTS: aluminium housing with salt-water resistant paintwork (size S)</li> <li>• VAM: stainless steel (size M)</li> <li>• CTM: aluminium housing with salt-water resistant paintwork (size M)</li> </ul>
5	A: US model (not described in this document)
6	Label for special versions (► <i>Special versions [p. 17]</i> )

### 3.4 Housing options

The rotary drive housing is normally painted (**InMax** model: green RAL6018, **RedMax** model: telemagenta RAL4010, **ExMax** model: yellow RAL1016). There are two special versions that are the exception to this:

- VAS/VAM: Corrosion-resistant housing material 1.4581 in stainless steel similar to AISI 316, some parts nickel plated, screws in stainless steel



- CTS/CTM: Aluminium housing with a saltwater-resistant offshore/marine coating in blue, resistant to corrosive and maritime atmosphere, some parts nickel plated, screws in stainless steel



### 3.5 Special versions

Label.	Properties
S1	<ul style="list-style-type: none"><li>• Drive unit without anti-backdrive mechanism (drive can be turned back by external load when the power is switched off).</li><li>• Cable length 1.5 m</li></ul>
S2	<ul style="list-style-type: none"><li>• No thermal cutoff (only available as <b>InMax</b>)</li></ul>
S3	<ul style="list-style-type: none"><li>• To +60 °C</li></ul> Restrictions <ul style="list-style-type: none"><li>– for <b>ExMax</b> and <b>RedMax</b>: Temperature class T4</li><li>– only suitable for <b>110 V ... 240 V</b></li><li>– maximum <b>25 % duty cycle</b></li><li>– cannot be supplied for Y drives</li></ul>
S7	<ul style="list-style-type: none"><li>• Only for <b>InMax</b></li><li>• Drive unit without anti-backdrive mechanism (drive can be turned back by external load when the power is switched off).</li><li>• Max-S with aluminium housing with additional damping elements, maximum load 500 g</li></ul>
S9	<ul style="list-style-type: none"><li>• No thermal cutoff (only available as <b>InMax</b>)</li><li>• Limit switch configured to 0/80° instead of 5/85°</li></ul>
S12	<ul style="list-style-type: none"><li>• Drive unit without anti-backdrive mechanism (drive can be turned back by external load when the power is switched off).</li></ul>
S14	<ul style="list-style-type: none"><li>• To +60 °C</li></ul> Restrictions <ul style="list-style-type: none"><li>– for <b>ExMax</b> and <b>RedMax</b>: Temperature class T4</li><li>– only suitable for <b>110 V ... 240 V</b></li><li>– cannot be supplied for Y drives</li></ul>
S17	<ul style="list-style-type: none"><li>• Cable length 3.0 m</li></ul>
S18	<ul style="list-style-type: none"><li>• Drive unit without anti-backdrive mechanism (drive can be turned back by external load when the power is switched off).</li><li>• Angle of rotation limited to 90 ° by the drive itself</li></ul>
S27	<ul style="list-style-type: none"><li>• To +60 °C</li></ul> Restrictions <ul style="list-style-type: none"><li>– for <b>ExMax</b> and <b>RedMax</b>: Temperature class T4</li><li>– only suitable for <b>110 V ... 240 V</b></li><li>– maximum <b>25 % duty cycle</b></li></ul>

## 3 | Device description

Label.	Properties
	<ul style="list-style-type: none"><li>– cannot be supplied for Y drives</li><li>• No regulation, just positioning<ul style="list-style-type: none"><li>– only for <b>InMax</b></li><li>– can only be supplied for Y drives</li></ul></li></ul>
S30	<ul style="list-style-type: none"><li>• Cable length 1.5 m</li><li>• Includes KIT protective hose VA</li></ul>
S31	<ul style="list-style-type: none"><li>• To +60 °C 24 VAC/DC</li></ul> Restrictions <ul style="list-style-type: none"><li>– for <b>ExMax</b> and <b>RedMax</b>: Temperature class T4</li><li>– maximum <b>15 % duty cycle</b></li><li>– cannot be supplied for Y drives</li></ul>
S32	<ul style="list-style-type: none"><li>• Drive unit without anti-backdrive mechanism (drive can be turned back by external load when the power is switched off).</li><li>• Max-S with aluminium housing with additional damping elements, maximum load 500 g</li><li>• Cable length 3.0 m</li><li>• To +60 °C</li></ul> Restrictions <ul style="list-style-type: none"><li>– for <b>ExMax</b> and <b>RedMax</b>: Temperature class T4</li><li>– only suitable for <b>110 V ... 240 V</b></li><li>– maximum <b>25 % duty cycle</b></li><li>– cannot be supplied for Y drives</li></ul>
S33	<ul style="list-style-type: none"><li>• Cable length 3.0 m</li><li>• To +60 °C</li></ul> Restrictions <ul style="list-style-type: none"><li>– for <b>ExMax</b> and <b>RedMax</b>: Temperature class T4</li><li>– only suitable for <b>110 V ... 240 V</b></li><li>– maximum <b>25 % duty cycle</b></li><li>– cannot be supplied for Y drives</li></ul>
S36	<ul style="list-style-type: none"><li>• Drive unit without anti-backdrive mechanism (drive can be turned back by external load when the power is switched off).</li><li>• Max-S with aluminium housing with additional damping elements, maximum load 500 g</li><li>• Cable length 3.0 m</li></ul>
S38	<ul style="list-style-type: none"><li>• Cable length 3.0 m</li></ul>

Label.	Properties
	<ul style="list-style-type: none"><li>• To +60 °C</li></ul> <p>Restrictions</p> <ul style="list-style-type: none"><li>– for <b>ExMax</b> and <b>RedMax</b>: Temperature class T4</li><li>– only suitable for 110 V ... 240 V</li><li>– maximum 25 % duty cycle</li><li>– cannot be supplied for Y drives</li></ul>

### 3.6 Function / performance characteristics

The rotary drives are used in technical building services, chemistry, pharmaceuticals, industry and offshore systems.

All rotary drives can be parameterised and adjusted locally without the use of additional electronic equipment. The motor run time and potentially the spring return periods can be selected locally.

The modular design enables upgrades with adjustable auxiliary switches and other accessories.

All rotary drives are distinguished by the following performance characteristics:

- 100 % blocking resistance
- Drives made from stainless steel and sintered steel
- Integrated heating to –40 °C ambient temperature
- Integrated safety temperature limiter
- Concealed controls for parameter setting (button, LED, switch)
- Preparation for upgrades and adjustable external auxiliary switches
- Comprehensive accessories concept

Special versions (label -F) are equipped with integrated spring-return function to implement safety settings.

### 3.7 Electrical connections

The following must be considered for the electrical connections:

- The drive units have automatic voltage detection for 24...240 VAC/DC and do not need to be adapted.
- The safety function for spring-return drives works by interrupting the supply voltage or, depending on the version, by opening cable 3.
- The electrical connection within the Ex-area must be done via an Ex e terminal box that is ATEX certified (e.g. ExBox) ▶ *Accessories [p. 170]*.

## 3 | Device description

- A device to protect against excess current < 10 A must be provided at the installation location.
- The start-up current is approx. 2 A for approx.1 second.
- Depending on the version, integrated limit switches signal the rotation angle setting.

In this section, the nominal values of the cable diameters are specified without the tolerances required in production.

### 3.7.1 3-point no spring return

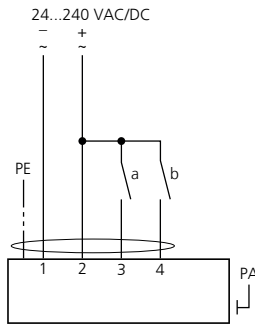

Fig. 3: SB1.0 - cable type 4+PE, cable diameter 7.2 mm

For explanation of the function of switches "a" and "b" see: ▶ *3-point standard operation* [p.194].

### 3.7.2 3-point with spring return with configurable spring return period

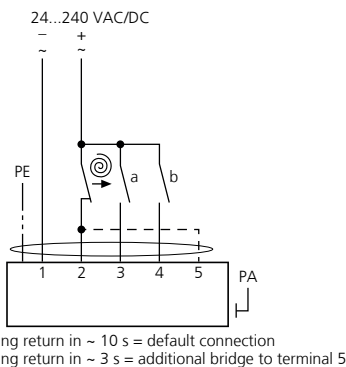

Fig. 4: SB2.0 - cable type 5+PE, cable diameter 7.5 mm



For explanation of the function of switches "a" and "b" see: ▶ *3-point standard operation* [p. 194].

### 3.7.3 1-wire with spring return with configurable spring return period

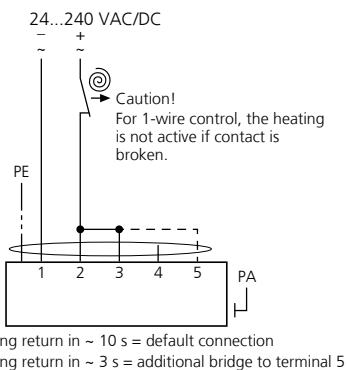

Fig. 5: SB2.1 - cable type 5+PE, cable diameter 7.5 mm

### 3.7.4 3-point with spring return constant spring return period

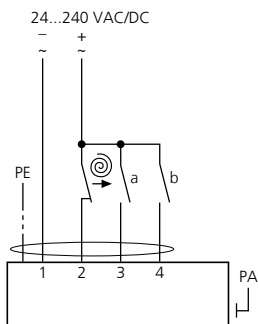

Fig. 6: SB2.2 - cable type 4+PE, cable diameter 7.2 mm

For explanation of the function of switches "a" and "b" see: ▶ *3-point standard operation* [p. 194].

### 3.7.5 1-wire with spring return constant spring return period

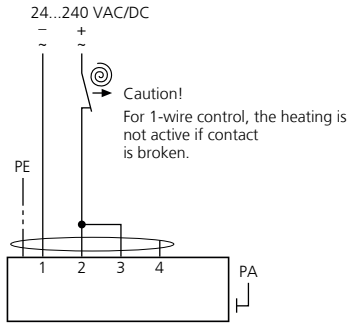

Fig. 7: SB2.3 - cable type 4+PE, cable diameter 7.2 mm

### 3.7.6 2-wire with spring return constant spring return period

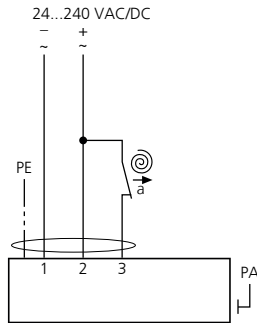

Fig. 8: SB2.4 - cable type 3+PE, cable diameter 6 mm

## 3.7.7 1-wire with spring return constant spring return period

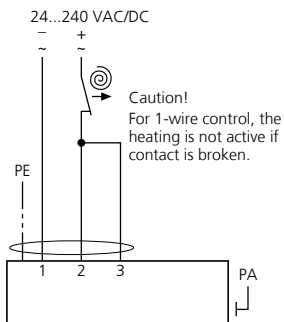

Fig. 9: SB2.5 - cable type 3+PE, cable diameter 6 mm

## 3.7.8 Integrated limit switch

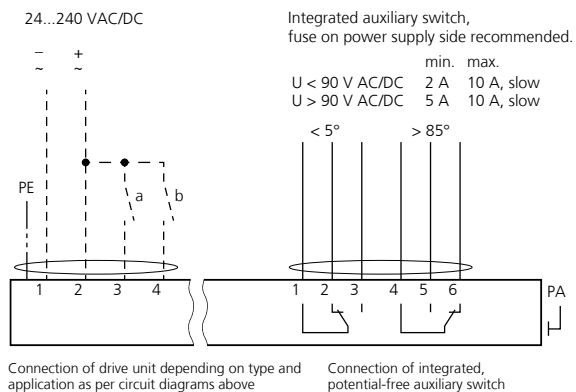

Fig. 10: SB3.0 - cable type 5+PE, cable diameter 7.5 mm / cable type 6, cable diameter 7.4 mm

## 3.7.9 Integrated limit switch

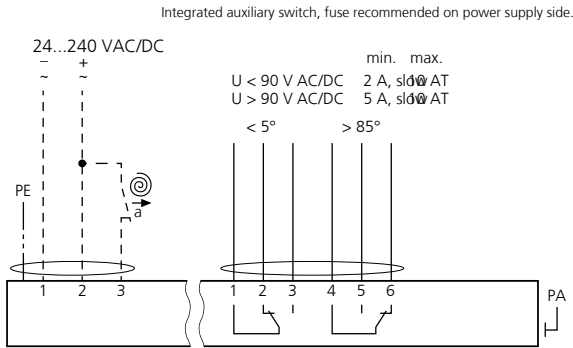

Fig. 11: SB3.2 - Connection of the integrated potential-free auxiliary switch

## 3.7.10 3-point with spring return constant spring return period continuous

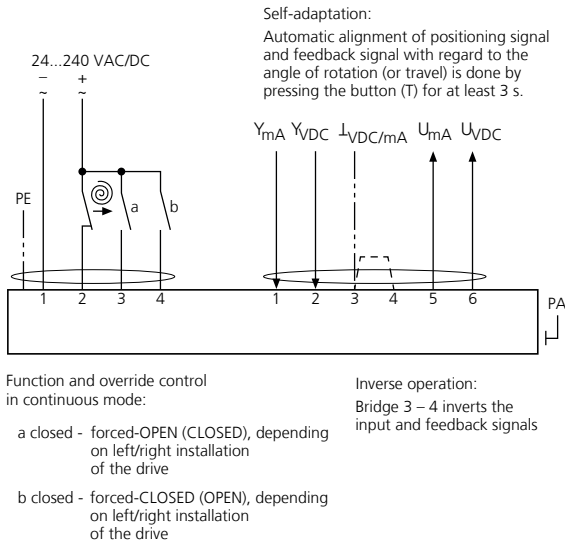

Fig. 12: SB4.0 - cable type 5+PE, cable diameter 7.5 mm / cable type 6, cable diameter 7.4 mm

For explanation of the function of switches "a" and "b" see: ▶ *3-point standard operation [p. 194]*.

### 3.7.11 1-wire with spring return with constant spring return period continuous

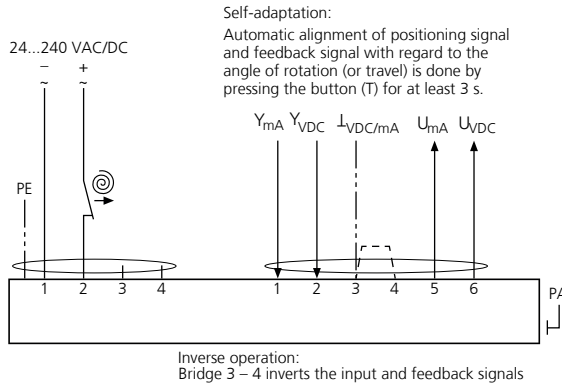

Fig. 13: SB4.1 - cable type 4+PE, cable diameter 7.2 mm / cable type 6, cable diameter 7.4 mm

### 3.7.12 3-point with spring return with configurable spring return period continuous

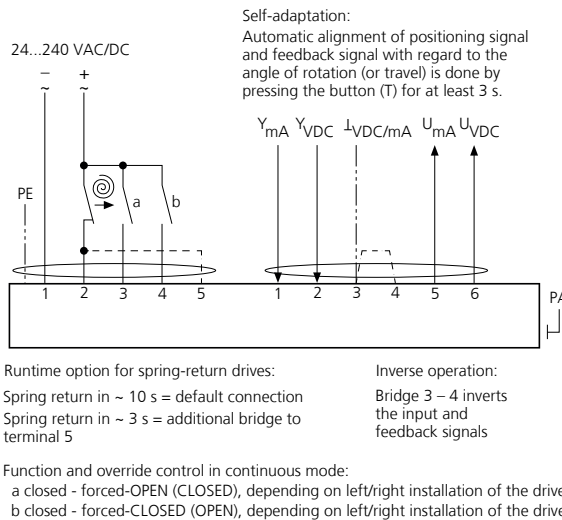

Fig. 14: SB5.0 - cable type 5+PE, cable diameter 7.5 mm / cable type 6, cable diameter 7.4 mm

## 3 | Device description

For explanation of the function of switches "a" and "b" see: ▶ *3-point standard operation* [p. 194].

### 3.7.13 1-wire with spring return with configurable spring return period continuous

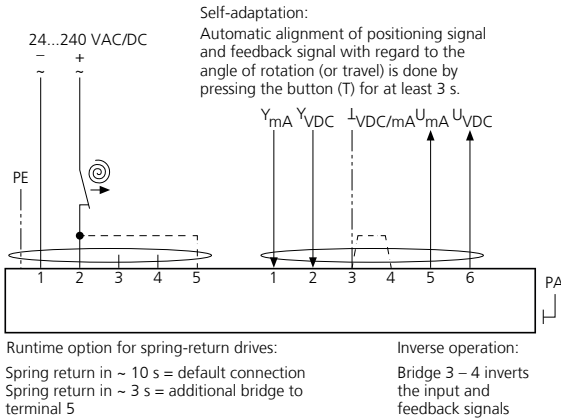

Fig. 15: SB5.1 - cable type 5+PE, cable diameter 7.5 mm / cable type 6, cable diameter 7.4 mm

### 3.7.14 1-wire with spring return continuous without feedback signal

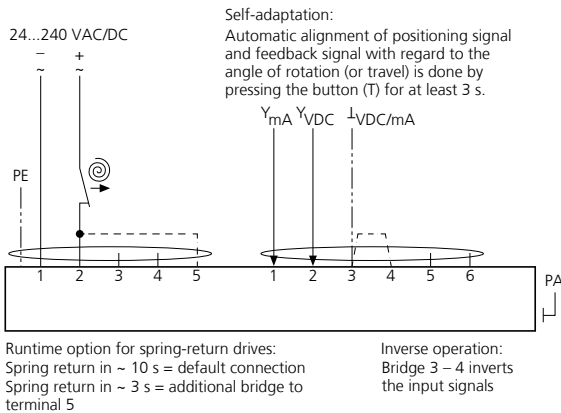

Fig. 16: SB5.2 - cable type 5+PE, cable diameter 7.5 mm / cable type 6, cable diameter 7.4 mm

## 3.7.15 3-point with spring return with configurable spring return period continuous feedback signal

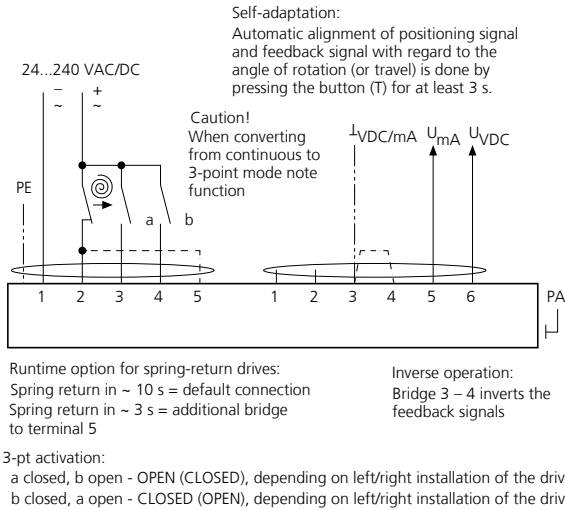

Fig. 17: SB5.3 - cable type 5+PE, cable diameter 7.5 mm / cable type 6, cable diameter 7.4 mm

For explanation of the function of switches "a" and "b" see: ▶ *3-point standard operation* [p.194].

## 3.7.16 Without spring return continuous activation

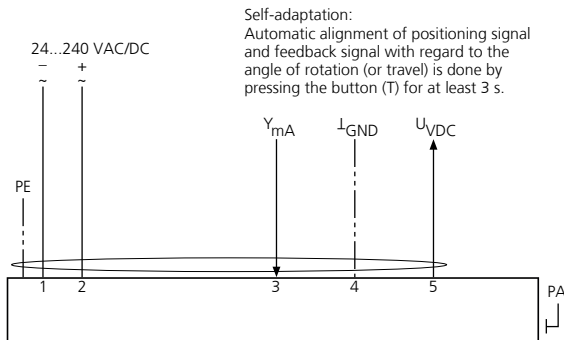

Fig. 18: SB6.0 - cable type 5+PE, cable diameter 7.5 mm

## 3 | Device description

### 3.7.17 1-wire with spring return continuous activation

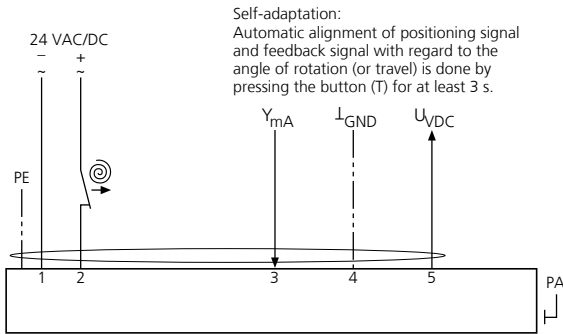

Fig. 19: SB6.1 - cable type 5+PE, cable diameter 7.5 mm

### 3.7.18 1-wire with spring return with configurable spring return period BF

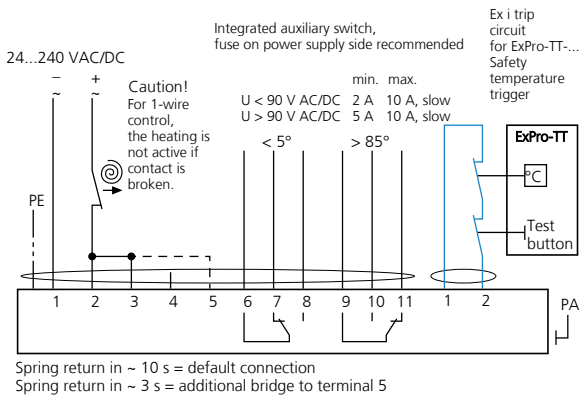

Fig. 20: SB7.0 - cable type 11+PE, cable diameter 9.9 mm



## 3.7.19 3-point with spring return with configurable spring return period BF

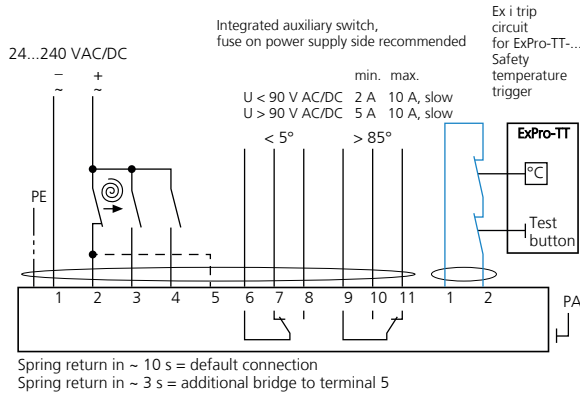

Fig. 21: SB7.1 - cable type 11+PE, cable diameter 9.9 mm

For explanation of the function of switches "a" and "b" see: ▶ [3-point standard operation \[p. 194\]](#).

## 3.7.20 1-wire with spring return with constant spring return period BF

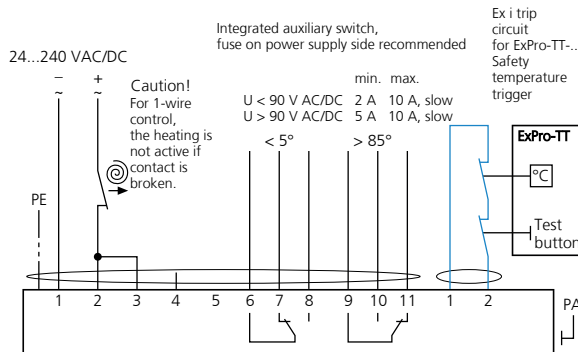

Fig. 22: SB7.2 - cable type 10+PE, cable diameter 9.4 mm

## 3 | Device description

### 3.7.21 3-point with spring return with constant spring return period BF

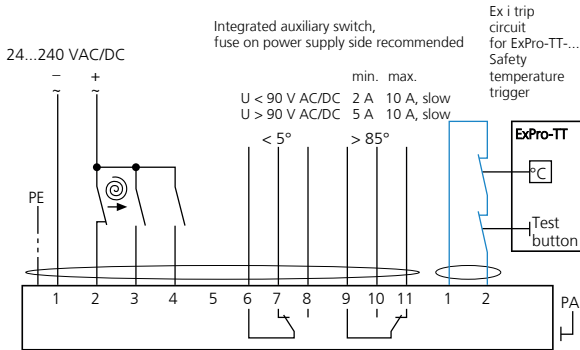

Fig. 23: SB7.3 - cable type 10+PE, cable diameter 9.4 mm

For explanation of the function of switches "a" and "b" see: ▶ *3-point standard operation [p.194]*.

### 3.7.22 1-wire with spring return constant spring return period BF1/BF3

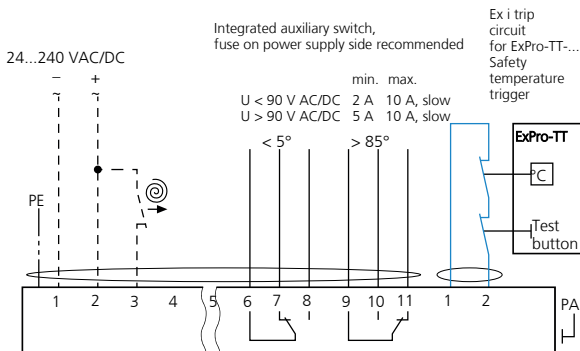

Fig. 24: SB7.4 - cable type 9+PE, cable diameter 8.8 mm

## 3.8 Power consumption as a function of supply voltage

Sizing of the on-site supply depends on the motor run time and supply voltage selected.

The values in the diagram are approximate, as there may be component variation within the electronics.

### Nominal currents for size S

		Nominal current as a function of motor run time				
Motor run time		3 / 7.5 s	15 s	30 s	60 s	120 s
Voltage	24 V DC	4.70 A	1.30 A	0.70 A	0.60 A	0.50 A
	120 V AC	0.75 A	0.30 A	0.25 A	0.20 A	0.17 A
	240 V AC	0.37 A	0.15 A	0.12 A	0.10 A	0.08 A

### Nominal currents for size M

		Nominal current as a function of motor run time				
Motor run time		40 s	60 s	90 s	120 s	150 s
Voltage	24 V DC	1.5 A	1.0 A	0.8 A	0.7 A	0.7 A
	120 V AC	0.26 A	0.18 A	0.14 A	0.12 A	0.12 A
	240 V AC	0.13 A	0.09 A	0.07 A	0.06 A	0.06 A

The holding power, irrespective of the run period, is typically 5 W. The heat output is ~ 16 W. **In heating mode, the motor is not running.**

When the supply voltage is switched on, the switching power supply for the drive needs ~ 2.0 A to start up. The switch-on pulse lasts approx. 1 second. This must be taken into account when sizing the wire cross-section.

Depending on the motor run time, the power factor is between 0.8 and 0.5. There should be a fuse on the power supply side with min. 2 AT.

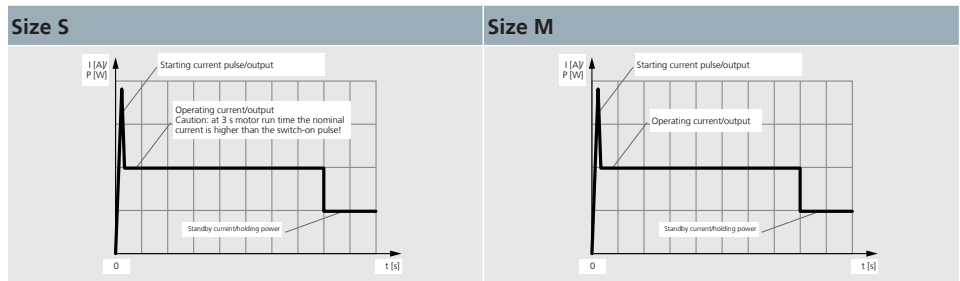

## 3.9 Wire cross-sections for the supply

If the power supply and drive unit are far apart, wire resistance can result in drops in voltage. For 24 VAC/DC this can result in the drive receiving insufficient power and thus no longer starting up. To prevent this, it is important to correctly size the wire cross-section for the power supply.

The following formulae allow you to calculate the necessary cross-section of the wire or the maximum wire length for the cross-section being used. Alternatively, a transformer can be used to increase the secondary voltage.

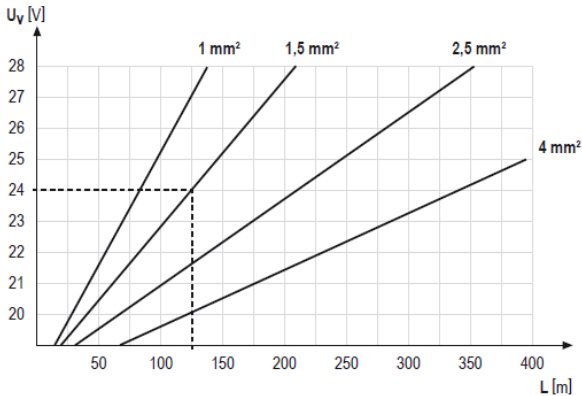

$$A = 0.0714 \times L : (U_v - 18 \text{ V})$$

$$L = A \times (U_v - 21.6 \text{ V}) : 0.0714$$

A = wire cross-section [mm<sup>2</sup>]

L = wire length [m]

U<sub>v</sub> = supply voltage [V]

Factor 0.0714 =  
drive-specific factor [Vmm<sup>2</sup>/m]

## 3.10 Technical data

### 3.10.1 Note on nominal values

For some of the characteristics listed in this section, no tolerance range ("min." / "max.") is specified but instead just a nominal value ("typ."). There are too many interdependent influences on the tolerance range to give generally applicable technically meaningful values.

Please get in touch if you need detailed information on this. Contact details can be found on page 2.

## 3.10.2 Max-5.10, Max-5.10-CTS, Max-5.10-VAS

Mechanical properties	min.	typ.	max.	unit
Motor torque (can be configured with rotary switch)*		5 / 10		Nm
Motor runtime for 90° (can be configured with rotary switch)*		3 15 30 60 120		s
Minimum angle of rotation*		-5		°
Maximum angle of rotation*		90		°
Weight* <ul style="list-style-type: none"> <li>• Max-5.10</li> <li>• Max-5.10-CTS</li> <li>• Max-5.10-VAS</li> </ul>		3.5 3.5 5.3		kg kg kg

Dimensions	min.	typ.	max.	unit
Max-5.10				
L	-1	210	+1	mm
W	-1	96	+1	mm
H	-1	80	+1	mm
Max-5.10-CTS				
L	-1	210	+1	mm
W	-1	96	+1	mm
H	-1	80	+1	mm
Max-5.10-VAS				
L	-1	211	+1	mm
W	-1	96	+1	mm
H	-1	81	+1	mm
Hollow shaft double square	12 × 12			mm
Allen key provided for manual adjustment in accordance with these instructions*		3		mm

Electrical characteristics	min.	typ.	max.	unit
Minimum nominal voltage (at room temperature)	-10 %	24	+10 %	VAC/DC
Maximum nominal voltage (at room temperature)	-10 %	240	+10 %	VAC/DC
Minimum mains frequency	-20 %	50	+20 %	Hz
Maximum mains frequency	-20 %	60	+20 %	Hz

Electrical characteristics	min.	typ.	max.	unit
Nominal current (at room temperature)	▶ <i>Power consumption as a function of supply voltage [p.31]</i>			
Power consumption standby*		5		W
Power consumption heating mode*		16		W
Power consumption in operation	▶ <i>Power consumption as a function of supply voltage [p.31]</i>			
Switch-on peak				
<ul style="list-style-type: none"> <li>at 24 VDC (for approx. 2 seconds)*</li> <li>at 240 VDC (for approx. 2 seconds)*</li> </ul>		2		A
		2		A
Maximum duty cycle for motor run time*	60 s enforced pause after 3 s motor operation			
3 s				
15 s, 30 s, 60 s, 120 s	100			%

### Electrical connection options

▶ <i>3-point no spring return [p.20]</i>	Cable type 4+PE, cable diameter 7.2 mm
--	--

Environmental conditions	min.	typ.	max.	unit
Humidity (not condensing)			90	% rH
Protection class as per DIN EN 60529	IP66			
Operation				
<ul style="list-style-type: none"> <li>Ambient temperature (T6)</li> </ul>	-40		+40	°C
<ul style="list-style-type: none"> <li>Ambient temperature (T5)</li> </ul>	-40		+50	°C
Storage				
<ul style="list-style-type: none"> <li>Ambient temperature</li> </ul>	-40		+70	°C

\*: Nominal value: please note that nominal values are also subject to tolerances. For more detailed information, see: ▶ *Note on nominal values [p.33]*

### 3.10.3 Max-5.10-Y, Max-5.10-Y-CTS, Max-5.10-Y-VAS

Mechanical properties	min.	typ.	max.	unit
Motor torque (can be configured with rotary switch)*		5 / 10		Nm
Motor runtime for 90° (can be configured with rotary switch)*		7.5 15 30 60 120		s
Minimum angle of rotation*		-5		°
Maximum angle of rotation*		90		°
Weight* <ul style="list-style-type: none"> <li>• Max-5.10-Y</li> <li>• Max-5.10-Y-CTS</li> <li>• Max-5.10-Y-VAS</li> </ul>		3.5 3.5 5.3		kg kg kg

Dimensions	min.	typ.	max.	unit
Max-5.10-Y				
L	-1	210	+1	mm
W	-1	96	+1	mm
H	-1	80	+1	mm
Max-5.10-Y-CTS				
L	-1	210	+1	mm
W	-1	96	+1	mm
H	-1	80	+1	mm
Max-5.10-Y-VAS				
L	-1	211	+1	mm
W	-1	96	+1	mm
H	-1	81	+1	mm
Hollow shaft double square	12 × 12			mm
Allen key provided for manual adjustment in accordance with these instructions*		3		mm

Electrical characteristics	min.	typ.	max.	unit
Minimum nominal voltage (at room temperature)	-10 %	24	+10 %	VAC/DC
Maximum nominal voltage (at room temperature)	-10 %	240	+10 %	VAC/DC
Minimum mains frequency	-20 %	50	+20 %	Hz
Maximum mains frequency	-20 %	60	+20 %	Hz



Electrical characteristics	min.	typ.	max.	unit
Nominal current (at room temperature)	▶ <i>Power consumption as a function of supply voltage [p.31]</i>			
Power consumption standby*		5		W
Power consumption heating mode*		16		W
Power consumption in operation	▶ <i>Power consumption as a function of supply voltage [p.31]</i>			
Switch-on peak				
<ul style="list-style-type: none"> <li>at 24 VDC (for approx. 2 seconds)*</li> <li>at 240 VDC (for approx. 2 seconds)*</li> </ul>		2		A
		2		A
Maximum duty cycle for motor run time	7.5 s, 15 s, 30 s, 60 s, 120 s			
		100		%

Electrical connection options	
▶ <i>3-point with spring return with configurable spring return period continuous [p.25]</i>	Cable type 5+PE, cable diameter 7.5 mm / cable type 6, cable diameter 7.4 mm
▶ <i>1-wire with spring return with configurable spring return period continuous [p.26]</i>	Cable type 5+PE, cable diameter 7.5 mm / cable type 6, cable diameter 7.4 mm
▶ <i>1-wire with spring return continuous without feedback signal [p.26]</i>	Cable type 5+PE, cable diameter 7.5 mm / cable type 6, cable diameter 7.4 mm
▶ <i>3-point with spring return with configurable spring return period continuous feedback signal [p.27]</i>	Cable type 5+PE, cable diameter 7.5 mm / cable type 6, cable diameter 7.4 mm

Activation CONTROL	min.	typ.	max.	unit
Angle of rotation and position indicator		95		°
Precision electrical*		~100		Step
Activation Y	0		10	VDC
	4		20	mA
Performance data Y and U				
<ul style="list-style-type: none"> <li>Activation <math>Y_U</math> (for 10 k<math>\Omega</math> output impedance)</li> <li>Activation <math>Y_I</math> (for 100 <math>\Omega</math> load / output impedance)</li> <li>Feedback <math>U_U</math> (for 10 k<math>\Omega</math>...<math>\infty</math> <math>\Omega</math> input impedance)</li> <li>Feedback <math>U_I</math> (for 0...800 <math>\Omega</math> load / input impedance)</li> </ul>	0		10	VDC
	4		20	mA
	0		10	VDC
	4		20	mA

## 3 | Device description

<b>Activation CONTROL</b>	<b>min.</b>	<b>typ.</b>	<b>max.</b>	<b>unit</b>
Inverting	Setting up wire bridges between terminals 3 and 4			
<b>Environmental conditions</b>	<b>min.</b>	<b>typ.</b>	<b>max.</b>	<b>unit</b>
Humidity (not condensing)			90	% rH
Protection class as per DIN EN 60529	IP66			
Operation				
• Ambient temperature (T6)	-40		+40	°C
• Ambient temperature (T5)	-40		+50	°C
Storage				
• Ambient temperature	-40		+70	°C

\*: Nominal value: please note that nominal values are also subject to tolerances. For more detailed information, see: ▶ *Note on nominal values [p.33]*

## 3.10.4 Max-5.10-S, Max-5.10-S-CTS, Max-5.10-S-VAS

Mechanical properties	min.	typ.	max.	unit
Motor torque (can be configured with rotary switch)*		5 / 10		Nm
Motor runtime for 90° (can be configured with rotary switch)*		3 15 30 60 120		s
Minimum angle of rotation*		-5		°
Maximum angle of rotation*		90		°
Weight* <ul style="list-style-type: none"> <li>• Max-5.10-S</li> <li>• Max-5.10-S-CTS</li> <li>• Max-5.10-S-VAS</li> </ul>		3.5 3.5 5.3		kg kg kg

Dimensions	min.	typ.	max.	unit
Max-5.10-S				
L	-1	210	+1	mm
W	-1	96	+1	mm
H	-1	80	+1	mm
Max-5.10-S-CTS				
L	-1	210	+1	mm
W	-1	96	+1	mm
H	-1	80	+1	mm
Max-5.10-S-VAS				
L	-1	211	+1	mm
W	-1	96	+1	mm
H	-1	81	+1	mm
Hollow shaft double square	12 × 12			mm
Allen key provided for manual adjustment in accordance with these instructions*		3		mm

Electrical characteristics	min.	typ.	max.	unit
Minimum nominal voltage (at room temperature)	-10 %	24	+10 %	VAC/DC
Maximum nominal voltage (at room temperature)	-10 %	240	+10 %	VAC/DC
Minimum mains frequency	-20 %	50	+20 %	Hz
Maximum mains frequency	-20 %	60	+20 %	Hz

## 3 | Device description

Electrical characteristics	min.	typ.	max.	unit
Nominal current (at room temperature)	▶ Power consumption as a function of supply voltage [p.31]			
Power consumption standby*		5		W
Power consumption heating mode*		16		W
Power consumption in operation	▶ Power consumption as a function of supply voltage [p.31]			
Switch-on peak				
<ul style="list-style-type: none"> <li>at 24 VDC (for approx. 2 seconds)*</li> </ul>		2		A
<ul style="list-style-type: none"> <li>at 240 VDC (for approx. 2 seconds)*</li> </ul>		2		A
Maximum duty cycle for motor run time*	60 s enforced pause after 3 s motor operation			
3 s				
15 s, 30 s, 60 s, 120 s	100			%

### Electrical connection options

▶ 3-point no spring return [p.20]	Cable type 4+PE, cable diameter 7.2 mm
▶ Integrated limit switch [p.23]	Cable type 6, cable diameter 7.4 mm

Electrical characteristics limit switch	min.	typ.	max.	unit
Switch point CLOSED	-2	5	+2	°
Switch point OPEN	-2	85	+2	°
Signal operation				
<ul style="list-style-type: none"> <li><math>U_{max}</math> DC*</li> </ul>		48		V
<ul style="list-style-type: none"> <li><math>I_{max}</math> DC*</li> </ul>		1		A
<ul style="list-style-type: none"> <li><math>I_{min}</math> AC/DC*</li> </ul>		5		mA
Power operation				
<ul style="list-style-type: none"> <li><math>U_{max}</math> AC*</li> </ul>		250		V
<ul style="list-style-type: none"> <li><math>U_{min}</math> AC/DC*</li> </ul>		5		V
<ul style="list-style-type: none"> <li><math>I_{max}</math> AC*</li> </ul>		5		A
After one-off operation with $U > 24$ VAC/DC or $I > 100$ mA:				
<ul style="list-style-type: none"> <li><math>U_{min}</math> AC/DC*</li> </ul>		12		V
<ul style="list-style-type: none"> <li><math>I_{min}</math> AC/DC*</li> </ul>		100		mA

<b>Environmental conditions</b>	<b>min.</b>	<b>typ.</b>	<b>max.</b>	<b>unit</b>
Humidity (not condensing)			90	% rH
Protection class as per DIN EN 60529	IP66			
Operation				
• Ambient temperature (T6)	-40		+40	°C
• Ambient temperature (T5)	-40		+50	°C
Storage				
• Ambient temperature	-40		+70	°C

\*: Nominal value: please note that nominal values are also subject to tolerances. For more detailed information, see: ▶ *Note on nominal values [p.33]*

## 3 | Device description

### 3.10.5 Max-5.10-F, Max-5.10-F-CTS, Max-5.10-F-VAS

Mechanical properties	min.	typ.	max.	unit
Motor torque (can be configured with rotary switch)*		5 / 10		Nm
Motor runtime for 90° (can be configured with rotary switch)*		3 15 30 60 120		s
Spring torque*		10		Nm
Spring return time for 90° (can be configured with wire bridge on connection)*		3 / 10		s
Minimum angle of rotation*		-5		°
Maximum angle of rotation*		90		°
Weight*				
<ul style="list-style-type: none"> <li>Max-5.10-F</li> </ul>		3.8		kg
<ul style="list-style-type: none"> <li>Max-5.10-F-CTS</li> </ul>		3.8		kg
<ul style="list-style-type: none"> <li>Max-5.10-F-VAS</li> </ul>		5.6		kg

Dimensions	min.	typ.	max.	unit
Max-5.10-F				
L	-1	210	+1	mm
W	-1	96	+1	mm
H	-1	80	+1	mm
Max-5.10-F-CTS				
L	-1	210	+1	mm
W	-1	96	+1	mm
H	-1	80	+1	mm
Max-5.10-F-VAS				
L	-1	211	+1	mm
W	-1	96	+1	mm
H	-1	81	+1	mm
Hollow shaft double square	12 × 12			mm
Allen key provided for manual adjustment in accordance with these instructions*		3		mm

Electrical characteristics	min.	typ.	max.	unit
Minimum nominal voltage (at room temperature)	-10 %	24	+10 %	VAC/DC
Maximum nominal voltage (at room temperature)	-10 %	240	+10 %	VAC/DC

Electrical characteristics	min.	typ.	max.	unit
Minimum mains frequency	-20 %	50	+20 %	Hz
Maximum mains frequency	-20 %	60	+20 %	Hz
Nominal current (at room temperature)	▶ <i>Power consumption as a function of supply voltage [p.31]</i>			
Power consumption standby*		5		W
Power consumption heating mode*		16		W
Power consumption in operation	▶ <i>Power consumption as a function of supply voltage [p.31]</i>			
Switch-on peak				
<ul style="list-style-type: none"> <li>at 24 VDC (for approx. 2 seconds)*</li> <li>at 240 VDC (for approx. 2 seconds)*</li> </ul>		2		A
		2		A
Maximum duty cycle for motor run time*	60 s enforced pause after 3 s motor operation			
3 s				
15 s, 30 s, 60 s, 120 s	100			%

## Electrical connection options

▶ <i>3-point with spring return with configurable spring return period [p.20]</i>	Cable type 5+PE, cable diameter 7.5 mm
▶ <i>1-wire with spring return with configurable spring return period [p.21]</i>	Cable type 5+PE, cable diameter 7.5 mm

Environmental conditions	min.	typ.	max.	unit
Humidity (not condensing)			90	% rH
Protection class as per DIN EN 60529	IP66			
Operation				
<ul style="list-style-type: none"> <li>Ambient temperature (T6)</li> <li>Ambient temperature (T5)</li> </ul>	-40		+40	°C
	-40		+50	°C
Storage				
<ul style="list-style-type: none"> <li>Ambient temperature</li> </ul>	-40		+70	°C

\*: Nominal value: please note that nominal values are also subject to tolerances. For more detailed information, see: ▶ *Note on nominal values [p.33]*

## 3 | Device description

### 3.10.6 Max-5.10-SF, Max-5.10-SF-CTS, Max-5.10-SF-VAS

Mechanical properties	min.	typ.	max.	unit
Motor torque (can be configured with rotary switch)*		5 / 10		Nm
Motor runtime for 90° (can be configured with rotary switch)*		3 15 30 60 120		s
Spring torque*		10		Nm
Spring return time for 90° (can be configured with wire bridge on connection)*		3 / 10		s
Minimum angle of rotation*		-5		°
Maximum angle of rotation*		90		°
Weight*				
<ul style="list-style-type: none"> <li>Max-5.10-SF</li> </ul>		3.8		kg
<ul style="list-style-type: none"> <li>Max-5.10-SF-CTS</li> </ul>		3.8		kg
<ul style="list-style-type: none"> <li>Max-5.10-SF-VAS</li> </ul>		5.6		kg

Dimensions	min.	typ.	max.	unit
Max-5.10-SF				
L	-1	210	+1	mm
W	-1	96	+1	mm
H	-1	80	+1	mm
Max-5.10-SF-CTS				
L	-1	210	+1	mm
W	-1	96	+1	mm
H	-1	80	+1	mm
Max-5.10-SF-VAS				
L	-1	211	+1	mm
W	-1	96	+1	mm
H	-1	81	+1	mm
Hollow shaft double square	12 × 12			mm
Allen key provided for manual adjustment in accordance with these instructions*		3		mm

Electrical characteristics	min.	typ.	max.	unit
Minimum nominal voltage (at room temperature)	-10 %	24	+10 %	VAC/DC
Maximum nominal voltage (at room temperature)	-10 %	240	+10 %	VAC/DC



Electrical characteristics	min.	typ.	max.	unit
Minimum mains frequency	-20 %	50	+20 %	Hz
Maximum mains frequency	-20 %	60	+20 %	Hz
Nominal current (at room temperature)	▶ <i>Power consumption as a function of supply voltage [p.31]</i>			
Power consumption standby*		5		W
Power consumption heating mode*		16		W
Power consumption in operation	▶ <i>Power consumption as a function of supply voltage [p.31]</i>			
Switch-on peak				
<ul style="list-style-type: none"> <li>at 24 VDC (for approx. 2 seconds)*</li> <li>at 240 VDC (for approx. 2 seconds)*</li> </ul>		2		A
		2		A
Maximum duty cycle for motor run time*	60 s enforced pause after 3 s motor operation			
3 s				
15 s, 30 s, 60 s, 120 s	100			%

## Electrical connection options

▶ <i>3-point with spring return with configurable spring return period [p.20]</i>	Cable type 5+PE, cable diameter 7.5 mm
▶ <i>1-wire with spring return with configurable spring return period [p.21]</i>	Cable type 5+PE, cable diameter 7.5 mm
▶ <i>Integrated limit switch [p.23]</i>	Cable type 6, cable diameter 7.4 mm

Electrical characteristics limit switch	min.	typ.	max.	unit
Switch point CLOSED	-2	5	+2	°
Switch point OPEN	-2	85	+2	°
Signal operation				
<ul style="list-style-type: none"> <li><math>U_{max}</math> DC*</li> <li><math>I_{max}</math> DC*</li> <li><math>I_{min}</math> AC/DC*</li> </ul>		48		V
		1		A
		5		mA
Power operation				
<ul style="list-style-type: none"> <li><math>U_{max}</math> AC*</li> <li><math>U_{min}</math> AC/DC*</li> <li><math>I_{max}</math> AC*</li> </ul>		250		V
		5		V
		5		A

## 3 | Device description

Electrical characteristics limit switch	min.	typ.	max.	unit
After one-off operation with $U > 24$ VAC/DC or $I > 100$ mA:				
• $U_{\min}$ AC/DC*		12		V
• $I_{\min}$ AC/DC*		100		mA
Environmental conditions	min.	typ.	max.	unit
Humidity (not condensing)			90	% rH
Protection class as per DIN EN 60529	IP66			
Operation				
• Ambient temperature (T6)	-40		+40	°C
• Ambient temperature (T5)	-40		+50	°C
Storage				
• Ambient temperature	-40		+70	°C

\*: Nominal value: please note that nominal values are also subject to tolerances. For more detailed information, see: ▶ *Note on nominal values [p.33]*

## 3.10.7 Max-5.10-YF, Max-5.10-YF-CTS, Max-5.10-YF-VAS

Mechanical properties	min.	typ.	max.	unit
Motor torque (can be configured with rotary switch)*		5 / 10		Nm
Motor runtime for 90° (can be configured with rotary switch)*		7.5 15 30 60 120		s
Spring torque*		10		Nm
Spring return time for 90° (can be configured with wire bridge on connection)*		3 / 10		s
Minimum angle of rotation*		-5		°
Maximum angle of rotation*		90		°
Weight*				
<ul style="list-style-type: none"> <li>• Max-5.10-YF</li> </ul>		3.8		kg
<ul style="list-style-type: none"> <li>• Max-5.10-YF-CTS</li> </ul>		3.8		kg
<ul style="list-style-type: none"> <li>• Max-5.10-YF-VAS</li> </ul>		5.6		kg

Dimensions	min.	typ.	max.	unit
Max-5.10-YF				
L	-1	210	+1	mm
W	-1	96	+1	mm
H	-1	80	+1	mm
Max-5.10-YF-CTS				
L	-1	210	+1	mm
W	-1	96	+1	mm
H	-1	80	+1	mm
Max-5.10-YF-VAS				
L	-1	211	+1	mm
W	-1	96	+1	mm
H	-1	81	+1	mm
Hollow shaft double square	12 × 12			mm
Allen key provided for manual adjustment in accordance with these instructions*		3		mm

Electrical characteristics	min.	typ.	max.	unit
Minimum nominal voltage (at room temperature)	-10 %	24	+10 %	VAC/DC
Maximum nominal voltage (at room temperature)	-10 %	240	+10 %	VAC/DC

## 3 | Device description

Electrical characteristics	min.	typ.	max.	unit
Minimum mains frequency	-20 %	50	+20 %	Hz
Maximum mains frequency	-20 %	60	+20 %	Hz
Nominal current (at room temperature)	▶ Power consumption as a function of supply voltage [p.31]			
Power consumption standby*		5		W
Power consumption heating mode*		16		W
Power consumption in operation	▶ Power consumption as a function of supply voltage [p.31]			
Switch-on peak				
<ul style="list-style-type: none"> <li>at 24 VDC (for approx. 2 seconds)*</li> <li>at 240 VDC (for approx. 2 seconds)*</li> </ul>		2		A
		2		A
Maximum duty cycle for motor run time				
7.5 s, 15 s, 30 s, 60 s, 120 s	100			%

### Electrical connection options

▶ 3-point with spring return with configurable spring return period continuous [p.25]	Cable type 5+PE, cable diameter 7.5 mm / cable type 6, cable diameter 7.4 mm			
▶ 1-wire with spring return with configurable spring return period continuous [p.26]	Cable type 5+PE, cable diameter 7.5 mm / cable type 6, cable diameter 7.4 mm			
▶ 1-wire with spring return continuous without feedback signal [p.26]	Cable type 5+PE, cable diameter 7.5 mm / cable type 6, cable diameter 7.4 mm			
▶ 3-point with spring return with configurable spring return period continuous feedback signal [p.27]	Cable type 5+PE, cable diameter 7.5 mm / cable type 6, cable diameter 7.4 mm			

Activation CONTROL	min.	typ.	max.	unit
Angle of rotation and position indicator		95		°
Precision electrical*		~100		Step
Activation Y	0		10	VDC
	4		20	mA

Activation CONTROL	min.	typ.	max.	unit
Performance data Y and U				
<ul style="list-style-type: none"> <li>• Activation <math>Y_U</math> (for 10 k<math>\Omega</math> output impedance)</li> <li>• Activation <math>Y_I</math> (for 100 <math>\Omega</math> load / output impedance)</li> <li>• Feedback <math>U_U</math> (for 10 k<math>\Omega</math>...<math>\infty</math> <math>\Omega</math> input impedance)</li> <li>• Feedback <math>U_I</math> (for 0...800 <math>\Omega</math> load / input impedance)</li> </ul>	0 4 0 4		10 20 10 20	VDC mA VDC mA
Inverting	Setting up wire bridges between terminals 3 and 4			

Environmental conditions	min.	typ.	max.	unit
Humidity (not condensing)			90	% rH
Protection class as per DIN EN 60529	IP66			
Operation				
<ul style="list-style-type: none"> <li>• Ambient temperature (T6)</li> <li>• Ambient temperature (T5)</li> </ul>	-40 -40		+40 +50	$^{\circ}$ C $^{\circ}$ C
Storage				
<ul style="list-style-type: none"> <li>• Ambient temperature</li> </ul>	-40		+70	$^{\circ}$ C

\*: Nominal value: please note that nominal values are also subject to tolerances. For more detailed information, see: ▶ *Note on nominal values [p.33]*

## 3.10.8 Max-5.10-BF, Max-5.10-BF-CTS, Max-5.10-BF-VAS

Mechanical properties	min.	typ.	max.	unit
Motor torque (can be configured with rotary switch)*		5 / 10		Nm
Motor runtime for 90° (can be configured with rotary switch)*		3 15 30 60 120		s
Spring torque*		10		Nm
Spring return time for 90° (can be configured with wire bridge on connection)*		3 / 10		s
Minimum angle of rotation*		-5		°
Maximum angle of rotation*		90		°
Weight*				
<ul style="list-style-type: none"> <li>• Max-5.10-BF</li> <li>• Max-5.10-BF-CTS</li> <li>• Max-5.10-BF-VAS</li> </ul>		3.8 3.8 5.6		kg kg kg

Dimensions	min.	typ.	max.	unit
Max-5.10-BF				
L	-1	210	+1	mm
W	-1	96	+1	mm
H	-1	80	+1	mm
Max-5.10-BF-CTS				
L	-1	210	+1	mm
W	-1	96	+1	mm
H	-1	80	+1	mm
Max-5.10-BF-VAS				
L	-1	211	+1	mm
W	-1	96	+1	mm
H	-1	81	+1	mm
Hollow shaft double square	12 × 12			mm
Allen key provided for manual adjustment in accordance with these instructions*		3		mm

Electrical characteristics	min.	typ.	max.	unit
Minimum nominal voltage (at room temperature)	-10 %	24	+10 %	VAC/DC
Maximum nominal voltage (at room temperature)	-10 %	240	+10 %	VAC/DC

Electrical characteristics	min.	typ.	max.	unit
Minimum mains frequency	-20 %	50	+20 %	Hz
Maximum mains frequency	-20 %	60	+20 %	Hz
Nominal current (at room temperature)	▶ <i>Power consumption as a function of supply voltage [p.31]</i>			
Power consumption standby*		5		W
Power consumption heating mode*		16		W
Power consumption in operation	▶ <i>Power consumption as a function of supply voltage [p.31]</i>			
Switch-on peak				
<ul style="list-style-type: none"> <li>at 24 VDC (for approx. 2 seconds)*</li> <li>at 240 VDC (for approx. 2 seconds)*</li> </ul>		2		A
		2		A
Maximum duty cycle for motor run time*	60 s enforced pause after 3 s motor operation			
3 s				
15 s, 30 s, 60 s, 120 s	100			%

## Electrical connection options

▶ *1-wire with spring return with configurable spring return period BF [p.28]* Cable type 11+PE, cable diameter 9.4 mm

▶ *3-point with spring return with configurable spring return period BF [p.29]* Cable type 11+PE, cable diameter 9.4 mm

Electrical characteristics limit switch	min.	typ.	max.	unit
Switch point CLOSED	-2	5	+2	°
Switch point OPEN	-2	85	+2	°
Signal operation				
<ul style="list-style-type: none"> <li><math>U_{max}</math> DC *</li> <li><math>I_{max}</math> DC *</li> <li><math>I_{min}</math> AC/DC *</li> </ul>		48		V
		1		A
		5		mA
Power operation				
<ul style="list-style-type: none"> <li><math>U_{max}</math> AC *</li> <li><math>U_{min}</math> AC/DC *</li> <li><math>I_{max}</math> AC *</li> </ul>		250		V
		5		V
		5		A

## 3 | Device description

Electrical characteristics limit switch	min.	typ.	max.	unit
After one-off operation with $U > 24$ VAC/DC or $I > 100$ mA:				
• $U_{\min}$ AC/DC*		12		V
• $I_{\min}$ AC/DC*		100		mA
Environmental conditions	min.	typ.	max.	unit
Humidity (not condensing)			90	% rH
Protection class as per DIN EN 60529	IP66			
Operation				
• Ambient temperature (T6)	-40		+40	°C
• Ambient temperature (T5)	-40		+50	°C
Storage				
• Ambient temperature	-40		+70	°C

\*: Nominal value: please note that nominal values are also subject to tolerances. For more detailed information, see: ▶ *Note on nominal values [p.33]*



## 3.10.9 Max-5.10-R, Max-5.10-R-CTS, Max-5.10-R-VAS

Mechanical properties	min.	typ.	max.	unit
Motor torque (can be configured with rotary switch)*		5 / 10		Nm
Motor runtime for 360° (can be configured with rotary switch)*		60 120 240 480		s
Angle of rotation*		rotary		
Weight* <ul style="list-style-type: none"> <li>• Max-5.10-R</li> <li>• Max-5.10-R-CTS</li> <li>• Max-5.10-R-VAS</li> </ul>		3.5 3.5 5.3		kg kg kg

Dimensions	min.	typ.	max.	unit
Max-5.10-R				
L	-1	210	+1	mm
W	-1	96	+1	mm
H	-1	80	+1	mm
Max-5.10-R-CTS				
L	-1	210	+1	mm
W	-1	96	+1	mm
H	-1	80	+1	mm
Max-5.10-R-VAS				
L	-1	211	+1	mm
W	-1	96	+1	mm
H	-1	81	+1	mm
Hollow shaft double square	12 × 12			mm
Allen key provided for manual adjustment in accordance with these instructions*		3		mm

Electrical characteristics	min.	typ.	max.	unit
Minimum nominal voltage (at room temperature)	-10 %	24	+10 %	VAC/DC
Maximum nominal voltage (at room temperature)	-10 %	240	+10 %	VAC/DC
Minimum mains frequency	-20 %	50	+20 %	Hz
Maximum mains frequency	-20 %	60	+20 %	Hz
Nominal current (at room temperature)	► Power consumption as a function of supply voltage [p.31]			

## 3 | Device description

Electrical characteristics	min.	typ.	max.	unit
Power consumption standby*		5		W
Power consumption heating mode*		16		W
Power consumption in operation	▶ Power consumption as a function of supply voltage [p.31]			
Switch-on peak				
<ul style="list-style-type: none"> <li>at 24 VDC (for approx. 2 seconds)*</li> </ul>		2		A
<ul style="list-style-type: none"> <li>at 240 VDC (for approx. 2 seconds)*</li> </ul>		2		A
Maximum duty cycle for motor operation*	100			%

Electrical connection options	
▶ 3-point no spring return [p.20]	Cable type 4+PE, cable diameter 7.2 mm

Environmental conditions	min.	typ.	max.	unit
Humidity (not condensing)			90	% rH
Protection class as per DIN EN 60529	IP66			
Operation				
<ul style="list-style-type: none"> <li>Ambient temperature (T6)</li> </ul>	-40		+40	°C
<ul style="list-style-type: none"> <li>Ambient temperature (T5)</li> </ul>	-40		+50	°C
Storage				
<ul style="list-style-type: none"> <li>Ambient temperature</li> </ul>	-40		+70	°C

\*: Nominal value: please note that nominal values are also subject to tolerances. For more detailed information, see: ▶ *Note on nominal values* [p.33]

## 3.10.10 Max-5.10-CY, Max-5.10-CY-CTS, Max-5.10-CY-VAS

Mechanical properties	min.	typ.	max.	unit
Motor torque (can be configured with rotary switch)*		5 / 10		Nm
Motor runtime for 90° (can be configured with rotary switch)*		7.5 15 30 60 120		s
Minimum angle of rotation*		-5		°
Maximum angle of rotation*		90		°
Weight* <ul style="list-style-type: none"> <li>• Max-5.10-CY</li> <li>• Max-5.10-CY-CTS</li> <li>• Max-5.10-CY-VAS</li> </ul>		3.5 3.5 5.3		kg kg kg

Dimensions	min.	typ.	max.	unit
Max-5.10-CY				
L	-1	210	+1	mm
W	-1	96	+1	mm
H	-1	80	+1	mm
Max-5.10-CY-CTS				
L	-1	210	+1	mm
W	-1	96	+1	mm
H	-1	80	+1	mm
Max-5.10-CY-VAS				
L	-1	211	+1	mm
W	-1	96	+1	mm
H	-1	81	+1	mm
Hollow shaft double square	12 × 12			mm
Allen key provided for manual adjustment in accordance with these instructions*		3		mm

Electrical characteristics	min.	typ.	max.	unit
Minimum nominal voltage (at room temperature)	-10 %	24	+10 %	VAC/DC
Maximum nominal voltage (at room temperature)	-10 %	240	+10 %	VAC/DC
Minimum mains frequency	-20 %	50	+20 %	Hz
Maximum mains frequency	-20 %	60	+20 %	Hz

## 3 | Device description

Electrical characteristics	min.	typ.	max.	unit
Power consumption standby*		5		W
Power consumption heating mode*		16		W
Power consumption in operation	▶ Power consumption as a function of supply voltage [p.31]			
Switch-on peak				
<ul style="list-style-type: none"> <li>at 24 VDC (for approx. 2 seconds)*</li> </ul>		2		A
<ul style="list-style-type: none"> <li>at 240 VDC (for approx. 2 seconds)*</li> </ul>		2		A
Maximum duty cycle for motor run time 7.5 s, 15 s, 30 s, 60 s, 120 s		100		%

### Electrical connection options

▶ Without spring return continuous activation [p.27]	Cable type 5+PE, cable diameter 7.5 mm
--	--

Activation CY-drives	min.	typ.	max.	unit
Power supply / frequency				
Minimum voltage	-10 %	24	+10 %	VAC/DC
Maximum voltage	-10 %	240	+10 %	VAC/DC
Minimum frequency	-20 %	50	+20 %	Hz
Maximum frequency	-20 %	60	+20 %	Hz
Activation Y		4	20	mA
Feedback signal U		0	10	VDC
Performance data Y and U				
<ul style="list-style-type: none"> <li>Activation <math>Y_U</math> (for 10 k<math>\Omega</math>)</li> </ul>		0	10	VDC
<ul style="list-style-type: none"> <li>Feedback <math>U_U</math> (for 2000 k<math>\Omega</math>...<math>\infty</math> <math>\Omega</math>)</li> </ul>		0	10	VDC

Environmental conditions	min.	typ.	max.	unit
Humidity (not condensing)			90	% rH
Protection class as per DIN EN 60529	IP66			
Operation				
<ul style="list-style-type: none"> <li>Ambient temperature (T6)</li> </ul>	-40		+40	°C
<ul style="list-style-type: none"> <li>Ambient temperature (T5)</li> </ul>	-40		+50	°C
Storage				
<ul style="list-style-type: none"> <li>Ambient temperature</li> </ul>	-40		+70	°C

\*: Nominal value: please note that nominal values are also subject to tolerances. For more detailed information, see: ▶ *Note on nominal values [p.33]*

## 3 | Device description

### 3.10.11 Max-5.10-CYF, Max-5.10-CYF-VAS

Mechanical properties	min.	typ.	max.	unit
Motor torque (can be configured with rotary switch)*		5 / 10		Nm
Motor runtime for 90° (can be configured with rotary switch)*		7.5 15 30 60 120		s
Spring torque*		10		Nm
Spring return time for 90° (can be configured with wire bridge on connection)*		3 / 10		s
Minimum angle of rotation*		-5		°
Maximum angle of rotation*		90		°
Weight*				
<ul style="list-style-type: none"> <li>Max-5.10-CYF</li> <li>Max-5.10-CYF-VAS</li> </ul>		3.8 5.6		kg kg

Dimensions	min.	typ.	max.	unit
Max-5.10-CYF				
L	-1	210	+1	mm
W	-1	96	+1	mm
H	-1	80	+1	mm
Max-5.10-CYF-VAS				
L	-1	211	+1	mm
W	-1	96	+1	mm
H	-1	81	+1	mm
Hollow shaft double square	12 × 12			mm
Allen key provided for manual adjustment in accordance with these instructions*		3		mm

Electrical characteristics	min.	typ.	max.	unit
Minimum nominal voltage (at room temperature)	-10 %	24	+10 %	VAC/DC
Maximum nominal voltage (at room temperature)	-10 %	240	+10 %	VAC/DC
Minimum mains frequency	-20 %	50	+20 %	Hz
Maximum mains frequency	-20 %	60	+20 %	Hz
Power consumption standby*		5		W
Power consumption heating mode*		16		W

Electrical characteristics	min.	typ.	max.	unit
Power consumption in operation	▶ <i>Power consumption as a function of supply voltage [p.31]</i>			
Switch-on peak				
<ul style="list-style-type: none"> <li>at 24 VDC (for approx. 2 seconds)*</li> <li>at 240 VDC (for approx. 2 seconds)*</li> </ul>		2		A
		2		A
Maximum duty cycle for motor run time				
7.5 s, 15 s, 30 s, 60 s, 120 s	100			%

## Electrical connection options

▶ <i>1-wire with spring return continuous activation [p.28]</i>	Cable type 5+PE, cable diameter 7.5 mm
---	--

Activation CY-drives	min.	typ.	max.	unit
Power supply / frequency				
Minimum voltage	-10 %	24	+10 %	VAC/DC
Maximum voltage	-10 %	240	+10 %	VAC/DC
Minimum frequency	-20 %	50	+20 %	Hz
Maximum frequency	-20 %	60	+20 %	Hz
Activation Y	4		20	mA
Feedback signal U	0		10	VDC
Performance data Y and U				
<ul style="list-style-type: none"> <li>Activation <math>Y_U</math> (for 10 k<math>\Omega</math>)</li> <li>Feedback <math>U_U</math> (for 2000 k<math>\Omega</math>...<math>\infty</math> <math>\Omega</math>)</li> </ul>	0		10	VDC
	0		10	VDC

Environmental conditions	min.	typ.	max.	unit
Humidity (not condensing)			90	% rH
Protection class as per DIN EN 60529	IP66			
Operation				
<ul style="list-style-type: none"> <li>Ambient temperature (T6)</li> <li>Ambient temperature (T5)</li> </ul>	-40		+40	°C
	-40		+50	°C
Storage				
<ul style="list-style-type: none"> <li>Ambient temperature</li> </ul>	-40		+70	°C

\*: Nominal value: please note that nominal values are also subject to tolerances. For more detailed information, see: ▶ *Note on nominal values [p.33]*

## 3.10.12 Max-15-F1, Max-15-F1-CTS, Max-15-F1-VAS

Mechanical properties	min.	typ.	max.	unit
Motor torque*		15		Nm
Motor runtime for 90° (can be configured with rotary switch)*		3 15 30 60 120		s
Spring torque*		12		Nm
Spring return period for 90° (The spring return time can vary at low temperatures. For further information, please contact our sales staff.)*		~1		s
Load torque, value must not be below this	5			Nm
Minimum angle of rotation*		-5		°
Maximum angle of rotation*		90		°
Weight* <ul style="list-style-type: none"> <li>• Max-15-F1</li> <li>• Max-15-F-CTS</li> <li>• Max-15-F1-VAS</li> </ul>		4.0 4.0 5.6		kg kg kg

Dimensions	min.	typ.	max.	unit
Max-15-F1				
L	-1	210	+1	mm
W	-1	96	+1	mm
H	-1	80	+1	mm
Max-15-F-CTS				
L	-1	210	+1	mm
W	-1	96	+1	mm
H	-1	80	+1	mm
Max-15-F1-VAS				
L	-1	211	+1	mm
W	-1	96	+1	mm
H	-1	81	+1	mm
Hollow shaft double square	12 × 12			mm
Allen key provided for manual adjustment in accordance with these instructions*		3		mm



Electrical characteristics	min.	typ.	max.	unit
Minimum nominal voltage (at room temperature)	-10 %	24	+10 %	VAC/DC
Maximum nominal voltage (at room temperature)	-10 %	240	+10 %	VAC/DC
Minimum mains frequency	-20 %	50	+20 %	Hz
Maximum mains frequency	-20 %	60	+20 %	Hz
Nominal current (at room temperature)	▶ <i>Power consumption as a function of supply voltage [p.31]</i>			
Power consumption standby*		5		W
Power consumption heating mode*		16		W
Power consumption in operation	▶ <i>Power consumption as a function of supply voltage [p.31]</i>			
Switch-on peak				
<ul style="list-style-type: none"> <li>at 24 VDC (for approx. 2 seconds)*</li> <li>at 240 VDC (for approx. 2 seconds)*</li> </ul>		2		A
		2		A
Maximum duty cycle for motor run time*	60 s enforced pause after 3 s motor operation			
3 s				
15 s, 30 s, 60 s, 120 s	100			%

## Electrical connection options

▶ <i>2-wire with spring return constant spring return period [p.22]</i>	Cable type 3+PE, cable diameter 6.0 mm
▶ <i>1-wire with spring return constant spring return period [p.23]</i>	Cable type 3+PE, cable diameter 6.0 mm

Ambient conditions	min.	typ.	max.	unit
Humidity (non-condensing)			90	% rH
Degree of protection to EN 60529	IP66			
Operation				
<ul style="list-style-type: none"> <li>Ambient temperature (T6)</li> <li>Ambient temperature (T5)</li> </ul>	-20		+40	°C
	-20		+50	°C
Storage				
<ul style="list-style-type: none"> <li>Ambient temperature</li> </ul>	-40		+70	°C

\*: Nominal value: please note that nominal values are also subject to tolerances. For more detailed information, see: ▶ *Note on nominal values [p.33]*

## 3.10.13 Max-15-F, Max-15-F-CTS, Max-15-F-VAS

Mechanical properties	min.	typ.	max.	unit
Motor torque (can be configured with rotary switch)*		15		Nm
Motor runtime for 90° (can be configured with rotary switch)*		3 15 30 60 120		s
Spring torque*		15		Nm
Spring return time for 90° (can be configured with wire bridge on connection)*		3 / 10		s
Minimum angle of rotation*		-5		°
Maximum angle of rotation*		90		°
Weight*				
• Max-15-F		3.8		kg
• Max-15-F-CTS		3.8		kg
• Max-15-F-VAS		5.6		kg

Dimensions	min.	typ.	max.	unit
Max-15-F				
L	-1	210	+1	mm
W	-1	96	+1	mm
H	-1	80	+1	mm
Max-15-F-CTS				
L	-1	210	+1	mm
W	-1	96	+1	mm
H	-1	80	+1	mm
Max-15-F-VAS				
L	-1	211	+1	mm
W	-1	96	+1	mm
H	-1	81	+1	mm
Hollow shaft double square	12 × 12			mm
Allen key provided for manual adjustment in accordance with these instructions*		3		mm

Electrical characteristics	min.	typ.	max.	unit
Minimum nominal voltage (at room temperature)	-10 %	24	+10 %	VAC/DC
Maximum nominal voltage (at room temperature)	-10 %	240	+10 %	VAC/DC

Electrical characteristics	min.	typ.	max.	unit
Minimum mains frequency	-20 %	50	+20 %	Hz
Maximum mains frequency	-20 %	60	+20 %	Hz
Nominal current (at room temperature)	▶ <i>Power consumption as a function of supply voltage [p.31]</i>			
Power consumption standby*		5		W
Power consumption heating mode*		16		W
Power consumption in operation	▶ <i>Power consumption as a function of supply voltage [p.31]</i>			
Switch-on peak				
<ul style="list-style-type: none"> <li>at 24 VDC (for approx. 2 seconds)*</li> <li>at 240 VDC (for approx. 2 seconds)*</li> </ul>		2		A
		2		A
Maximum duty cycle for motor run time*	60 s enforced pause after 3 s motor operation			
3 s	100			%
15 s, 30 s, 60 s, 120 s				

## Electrical connection options

▶ <i>3-point with spring return with configurable spring return period [p.20]</i>	Cable type 5+PE, cable diameter 7.5 mm
▶ <i>1-wire with spring return with configurable spring return period [p.21]</i>	Cable type 5+PE, cable diameter 7.5 mm

Environmental conditions	min.	typ.	max.	unit
Humidity (not condensing)			90	% rH
Protection class as per DIN EN 60529	IP66			
Operation				
<ul style="list-style-type: none"> <li>Ambient temperature (T6)</li> <li>Ambient temperature (T5)</li> </ul>	-40		+40	°C
	-40		+50	°C
Storage				
<ul style="list-style-type: none"> <li>Ambient temperature</li> </ul>	-40		+70	°C

\*: Nominal value: please note that nominal values are also subject to tolerances. For more detailed information, see: ▶ *Note on nominal values [p.33]*

## 3.10.14 Max-15-SF, Max-15-SF-CTS, Max-15-SF-VAS

Mechanical properties	min.	typ.	max.	unit
Motor torque*		15		Nm
Motor runtime for 90° (can be configured with rotary switch)*		3 15 30 60 120		s
Spring torque*		15		Nm
Spring return time for 90° (can be configured with rotary switch)*		3 / 10		s
Minimum angle of rotation*		-5		°
Maximum angle of rotation*		90		°
Weight*				
<ul style="list-style-type: none"> <li>• Max-15-SF</li> </ul>		3.8		kg
<ul style="list-style-type: none"> <li>• Max-15-SF-CTS</li> </ul>		3.8		kg
<ul style="list-style-type: none"> <li>• Max-15-SF-VAS</li> </ul>		5.6		kg

Dimensions	min.	typ.	max.	unit
Max-15-SF				
L	-1	210	+1	mm
W	-1	96	+1	mm
H	-1	80	+1	mm
Max-15-SF-CTS				
L	-1	210	+1	mm
W	-1	96	+1	mm
H	-1	80	+1	mm
Max-15-SF-VAS				
L	-1	211	+1	mm
W	-1	96	+1	mm
H	-1	81	+1	mm
Hollow shaft double square	12 × 12			mm
Allen key provided for manual adjustment in accordance with these instructions*		3		mm

Electrical characteristics	min.	typ.	max.	unit
Minimum nominal voltage (at room temperature)	-10 %	24	+10 %	VAC/DC
Maximum nominal voltage (at room temperature)	-10 %	240	+10 %	VAC/DC

Electrical characteristics	min.	typ.	max.	unit
Minimum mains frequency	-20 %	50	+20 %	Hz
Maximum mains frequency	-20 %	60	+20 %	Hz
Nominal current (at room temperature)	▶ <i>Power consumption as a function of supply voltage [p.31]</i>			
Power consumption standby*		5		W
Power consumption heating mode*		16		W
Power consumption in operation	▶ <i>Power consumption as a function of supply voltage [p.31]</i>			
Switch-on peak				
<ul style="list-style-type: none"> <li>at 24 VDC (for approx. 2 seconds)*</li> <li>at 240 VDC (for approx. 2 seconds)*</li> </ul>		2		A
		2		A
Maximum duty cycle for motor run time*	60 s enforced pause after 3 s motor operation			
3 s				
15 s, 30 s, 60 s, 120 s	100			%

## Electrical connection options

▶ <i>3-point with spring return with configurable spring return period [p.20]</i>	Cable type 5+PE, cable diameter 7.5 mm
▶ <i>1-wire with spring return with configurable spring return period [p.21]</i>	Cable type 5+PE, cable diameter 7.5 mm
▶ <i>Integrated limit switch [p.23]</i>	Cable type 6, cable diameter 7.4 mm

Electrical characteristics limit switch	min.	typ.	max.	unit
Switch point CLOSED	-2	5	+2	°
Switch point OPEN	-2	85	+2	°
Signal operation				
<ul style="list-style-type: none"> <li><math>U_{max}</math> DC*</li> <li><math>I_{max}</math> DC*</li> <li><math>I_{min}</math> AC/DC*</li> </ul>		48		V
		1		A
		5		mA
Power operation				
<ul style="list-style-type: none"> <li><math>U_{max}</math> AC*</li> <li><math>U_{min}</math> AC/DC*</li> <li><math>I_{max}</math> AC*</li> </ul>		250		V
		5		V
		5		A

## 3 | Device description

Electrical characteristics limit switch	min.	typ.	max.	unit
After one-off operation with $U > 24$ VAC/DC or $I > 100$ mA:				
• $U_{\min}$ AC/DC*		12		V
• $I_{\min}$ AC/DC*		100		mA
Environmental conditions	min.	typ.	max.	unit
Humidity (not condensing)			90	% rH
Protection class as per DIN EN 60529	IP66			
Operation				
• Ambient temperature (T6)	-40		+40	°C
• Ambient temperature (T5)	-40		+50	°C
Storage				
• Ambient temperature	-40		+70	°C

\*: Nominal value: please note that nominal values are also subject to tolerances. For more detailed information, see: ▶ *Note on nominal values [p.33]*

## 3.10.15 Max-15-SF1, Max-15-SF1-CTS, Max-15-SF1-VAS

Mechanical properties	min.	typ.	max.	unit
Motor torque*		15		Nm
Motor runtime for 90° (can be configured with rotary switch)*		3 15 30 60 120		s
Spring torque*		12		Nm
Spring return period for 90° (The spring return time can vary at low temperatures. For further information, please contact our sales staff.)*		~1		s
Load torque, value must not be below this	5			Nm
Minimum angle of rotation*		-5		°
Maximum angle of rotation*		90		°
Weight*				
<ul style="list-style-type: none"> <li>• Max-15-SF1</li> <li>• Max-15-SF1-CTS</li> <li>• Max-15-SF1-VAS</li> </ul>		4.0 4.0 5.6		kg kg kg

Dimensions	min.	typ.	max.	unit
Max-15-SF1				
L	-1	210	+1	mm
W	-1	96	+1	mm
H	-1	80	+1	mm
Max-15-SF1-CTS				
L	-1	210	+1	mm
W	-1	96	+1	mm
H	-1	80	+1	mm
Max-15-SF1-VAS				
L	-1	211	+1	mm
W	-1	96	+1	mm
H	-1	81	+1	mm
Hollow shaft double square	12 × 12			mm
Allen key provided for manual adjustment in accordance with these instructions*		3		mm

## 3 | Device description

Electrical characteristics	min.	typ.	max.	unit
Minimum nominal voltage (at room temperature)	-10 %	24	+10 %	VAC/DC
Maximum nominal voltage (at room temperature)	-10 %	240	+10 %	VAC/DC
Minimum mains frequency	-20 %	50	+20 %	Hz
Maximum mains frequency	-20 %	60	+20 %	Hz
Nominal current (at room temperature)	▶ Power consumption as a function of supply voltage [p.31]			
Power consumption standby*		5		W
Power consumption heating mode*		16		W
Power consumption in operation	▶ Power consumption as a function of supply voltage [p.31]			
Switch-on peak				
<ul style="list-style-type: none"> <li>at 24 VDC (for approx. 2 seconds)*</li> <li>at 240 VDC (for approx. 2 seconds)*</li> </ul>		2		A
		2		A
Maximum duty cycle for motor run time*				
3 s	60 s enforced pause after 3 s motor operation			
15 s, 30 s, 60 s, 120 s	100			%

### Electrical connection options

▶ 2-wire with spring return constant spring return period [p.22]	Cable type 3+PE, cable diameter 6.0 mm
▶ 1-wire with spring return constant spring return period [p.23]	Cable type 3+PE, cable diameter 6.0 mm
▶ Integrated limit switch [p.24]	Cable type 6, cable diameter 7.4 mm

Electrical characteristics limit switch	min.	typ.	max.	unit
Switch point CLOSED	-2	5	+2	°
Switch point OPEN	-2	85	+2	°
Signal operation				
<ul style="list-style-type: none"> <li><math>U_{max}</math> DC*</li> <li><math>I_{max}</math> DC*</li> <li><math>I_{min}</math> AC/DC*</li> </ul>		48		V
		1		A
		5		mA



Electrical characteristics limit switch	min.	typ.	max.	unit
Power operation				
• $U_{\max}$ AC*		250		V
• $U_{\min}$ AC/DC*		5		V
• $I_{\max}$ AC*		5		A
After one-off operation with $U > 24$ VAC/DC or $I > 100$ mA:				
• $U_{\min}$ AC/DC*		12		V
• $I_{\min}$ AC/DC*		100		mA
Ambient conditions	min.	typ.	max.	unit
Humidity (non-condensing)			90	% rH
Degree of protection to EN 60529	IP66			
Operation				
• Ambient temperature (T6)	-20		+40	°C
• Ambient temperature (T5)	-20		+50	°C
Storage				
• Ambient temperature	-40		+70	°C

\*: Nominal value: please note that nominal values are also subject to tolerances. For more detailed information, see: ▶ *Note on nominal values [p.33]*

## 3.10.16 Max-15-YF, Max-15-YF-CTS, Max-15-YF-VAS

Mechanical properties	min.	typ.	max.	unit
Motor torque*		15		Nm
Motor runtime for 90° (can be configured with rotary switch)*		7.5 15 30 60 120		s
Spring torque*		15		Nm
Spring return time for 90° (can be configured with rotary switch)*		3 / 10		s
Minimum angle of rotation*		-5		°
Maximum angle of rotation*		90		°
Weight*				
<ul style="list-style-type: none"> <li>• Max-15-YF</li> <li>• Max-15-YF-CTS</li> <li>• Max-15-YF-VAS</li> </ul>		3.8 3.8 5.6		kg kg kg

Dimensions	min.	typ.	max.	unit
Max-15-YF				
L	-1	210	+1	mm
W	-1	96	+1	mm
H	-1	80	+1	mm
Max-15-YF-CTS				
L	-1	210	+1	mm
W	-1	96	+1	mm
H	-1	80	+1	mm
Max-15-YF-VAS				
L	-1	211	+1	mm
W	-1	96	+1	mm
H	-1	81	+1	mm
Hollow shaft double square	12 × 12			mm
Allen key provided for manual adjustment in accordance with these instructions*		3		mm

Electrical characteristics	min.	typ.	max.	unit
Minimum nominal voltage (at room temperature)	-10 %	24	+10 %	VAC/DC
Maximum nominal voltage (at room temperature)	-10 %	240	+10 %	VAC/DC

Electrical characteristics	min.	typ.	max.	unit
Minimum mains frequency	-20 %	50	+20 %	Hz
Maximum mains frequency	-20 %	60	+20 %	Hz
Nominal current (at room temperature)	▶ <i>Power consumption as a function of supply voltage [p.31]</i>			
Power consumption standby*		5		W
Power consumption heating mode*		16		W
Power consumption in operation	▶ <i>Power consumption as a function of supply voltage [p.31]</i>			
Switch-on peak				
<ul style="list-style-type: none"> <li>at 24 VDC (for approx. 2 seconds)*</li> <li>at 240 VDC (for approx. 2 seconds)*</li> </ul>		2		A
		2		A
Maximum duty cycle for motor run time				
7.5 s, 15 s, 30 s, 60 s, 120 s	100			%

## Electrical connection options

▶ <i>3-point with spring return with configurable spring return period continuous [p.25]</i>	Cable type 5+PE, cable diameter 7.5 mm / cable type 6, cable diameter 7.4 mm
▶ <i>1-wire with spring return with configurable spring return period continuous [p.26]</i>	Cable type 5+PE, cable diameter 7.5 mm / cable type 6, cable diameter 7.4 mm
▶ <i>1-wire with spring return continuous without feedback signal [p.26]</i>	Cable type 5+PE, cable diameter 7.5 mm / cable type 6, cable diameter 7.4 mm
▶ <i>3-point with spring return with configurable spring return period continuous feedback signal [p.27]</i>	Cable type 5+PE, cable diameter 7.5 mm / cable type 6, cable diameter 7.4 mm

Activation CONTROL	min.	typ.	max.	unit
Angle of rotation and position indicator		95		°
Precision electrical*		~100		Step
Activation Y	0		10	VDC
	4		20	mA

## 3 | Device description

Activation CONTROL	min.	typ.	max.	unit
Performance data Y and U				
• Activation $Y_U$ (for 10 k $\Omega$ output impedance)	0		10	VDC
• Activation $Y_I$ (for 100 $\Omega$ load / output impedance)	4		20	mA
• Feedback $U_U$ (for 10 k $\Omega$ ... $\infty$ $\Omega$ input impedance)	0		10	VDC
• Feedback $U_I$ (for 0...800 $\Omega$ load / input impedance)	4		20	mA
Inverting	Setting up wire bridges between terminals 3 and 4			
Environmental conditions	min.	typ.	max.	unit
Humidity (not condensing)			90	% rH
Protection class as per DIN EN 60529	IP66			
Operation				
• Ambient temperature (T6)	-40		+40	$^{\circ}$ C
• Ambient temperature (T5)	-40		+50	$^{\circ}$ C
Storage				
• Ambient temperature	-40		+70	$^{\circ}$ C

\*: Nominal value: please note that nominal values are also subject to tolerances. For more detailed information, see: ▶ *Note on nominal values [p.33]*

## 3.10.17 Max-15-BF1, Max-15-BF1-CTS, Max-15-BF1-VAS

Mechanical properties	min.	typ.	max.	unit
Motor torque*		15		Nm
Motor runtime for 90° (can be configured with rotary switch)*		3 15 30 60 120		s
Spring torque*		12		Nm
Spring return period for 90° (The spring return time can vary at low temperatures. For further information, please contact our sales staff.)*		~1		s
Load torque, value must not be below this	5			Nm
Minimum angle of rotation*		-5		°
Maximum angle of rotation*		90		°
Weight*				
<ul style="list-style-type: none"> <li>• Max-15-BF1</li> <li>• Max-15-BF1-CTS</li> <li>• Max-15-BF1-VAS</li> </ul>		4.0 4.0 5.6		kg kg kg

Dimensions	min.	typ.	max.	unit
Max-15-BF1				
L	-1	210	+1	mm
W	-1	96	+1	mm
H	-1	80	+1	mm
Max-15-BF1-CTS				
L	-1	210	+1	mm
W	-1	96	+1	mm
H	-1	80	+1	mm
Max-15-BF1-VAS				
L	-1	211	+1	mm
W	-1	96	+1	mm
H	-1	81	+1	mm
Hollow shaft double square	12 × 12			mm
Allen key provided for manual adjustment in accordance with these instructions*		3		mm

## 3 | Device description

Electrical characteristics	min.	typ.	max.	unit
Minimum nominal voltage (at room temperature)	-10 %	24	+10 %	VAC/DC
Maximum nominal voltage (at room temperature)	-10 %	240	+10 %	VAC/DC
Minimum mains frequency	-20 %	50	+20 %	Hz
Maximum mains frequency	-20 %	60	+20 %	Hz
Nominal current (at room temperature)	▶ Power consumption as a function of supply voltage [p.31]			
Power consumption standby*		5		W
Power consumption heating mode*		16		W
Power consumption in operation	▶ Power consumption as a function of supply voltage [p.31]			
Switch-on peak				
<ul style="list-style-type: none"> <li>at 24 VDC (for approx. 2 seconds)*</li> <li>at 240 VDC (for approx. 2 seconds)*</li> </ul>		2		A
		2		A
Maximum duty cycle for motor run time*				
3 s	60 s enforced pause after 3 s motor operation			
15 s, 30 s, 60 s, 120 s	100			%

### Electrical connection options

▶ 2-wire with spring return constant spring return period [p.22]	Cable type 3+PE, cable diameter 6.0 mm
▶ 1-wire with spring return constant spring return period [p.23]	Cable type 3+PE, cable diameter 6.0 mm
▶ 1-wire with spring return constant spring return period BF1/BF3 [p.30]	Cable type 9+PE, cable diameter 8.8 mm

### Electrical characteristics limit switch

	min.	typ.	max.	unit
Switch point CLOSED	-2	5	+2	°
Switch point OPEN	-2	85	+2	°
Signal operation				
<ul style="list-style-type: none"> <li><math>U_{\max}</math> DC*</li> <li><math>I_{\max}</math> DC*</li> <li><math>I_{\min}</math> AC/DC*</li> </ul>		48		V
		1		A
		5		mA

Electrical characteristics limit switch	min.	typ.	max.	unit
Power operation				
• $U_{\max}$ AC*		250		V
• $U_{\min}$ AC/DC*		5		V
• $I_{\max}$ AC*		5		A
After one-off operation with $U > 24$ VAC/DC or $I > 100$ mA:				
• $U_{\min}$ AC/DC*		12		V
• $I_{\min}$ AC/DC*		100		mA
Ambient conditions	min.	typ.	max.	unit
Humidity (non-condensing)			90	% rH
Degree of protection to EN 60529	IP66			
Operation				
• Ambient temperature (T6)	-20		+40	°C
• Ambient temperature (T5)	-20		+50	°C
Storage				
• Ambient temperature	-40		+70	°C

\*: Nominal value: please note that nominal values are also subject to tolerances. For more detailed information, see: ▶ *Note on nominal values [p.33]*

## 3.10.18 Max-15-BF, Max-15-BF-CTS, Max-15-BF-VAS

Mechanical properties	min.	typ.	max.	unit
Motor torque*		15		Nm
Motor runtime for 90° (can be configured with rotary switch)*		3 15 30 60 120		s
Spring torque*		15		Nm
Spring return time for 90° (can be configured with rotary switch)*		3 / 10		s
Minimum angle of rotation*		-5		°
Maximum angle of rotation*		90		°
Weight*				
<ul style="list-style-type: none"> <li>• Max-15-BF</li> <li>• Max-15-BF-CTS</li> <li>• Max-15-BF-VAS</li> </ul>		3.8 3.8 5.6		kg kg kg

Dimensions	min.	typ.	max.	unit
Max-15-BF				
L	-1	210	+1	mm
W	-1	96	+1	mm
H	-1	80	+1	mm
Max-15-BF-CTS				
L	-1	210	+1	mm
W	-1	96	+1	mm
H	-1	80	+1	mm
Max-15-BF-VAS				
L	-1	211	+1	mm
W	-1	96	+1	mm
H	-1	81	+1	mm
Hollow shaft double square	12 × 12			mm
Allen key provided for manual adjustment in accordance with these instructions*		3		mm

Electrical characteristics	min.	typ.	max.	unit
Minimum nominal voltage (at room temperature)	-10 %	24	+10 %	VAC/DC
Maximum nominal voltage (at room temperature)	-10 %	240	+10 %	VAC/DC



Electrical characteristics	min.	typ.	max.	unit
Minimum mains frequency	-20 %	50	+20 %	Hz
Maximum mains frequency	-20 %	60	+20 %	Hz
Nominal current (at room temperature)	▶ <i>Power consumption as a function of supply voltage [p.31]</i>			
Power consumption standby*		5		W
Power consumption heating mode*		16		W
Power consumption in operation	▶ <i>Power consumption as a function of supply voltage [p.31]</i>			
Switch-on peak				
<ul style="list-style-type: none"> <li>at 24 VDC (for approx. 2 seconds)*</li> <li>at 240 VDC (for approx. 2 seconds)*</li> </ul>		2		A
		2		A
Maximum duty cycle for motor run time*	60 s enforced pause after 3 s motor operation			
3 s				
15 s, 30 s, 60 s, 120 s	100			%

## Electrical connection options

▶ *1-wire with spring return with configurable spring return period BF [p.28]* Cable type 11+PE, cable diameter 9.4 mm

▶ *3-point with spring return with configurable spring return period BF [p.29]* Cable type 11+PE, cable diameter 9.4 mm

Electrical characteristics limit switch	min.	typ.	max.	unit
Switch point CLOSED	-2	5	+2	°
Switch point OPEN	-2	85	+2	°
Signal operation				
<ul style="list-style-type: none"> <li><math>U_{max}</math> DC *</li> <li><math>I_{max}</math> DC *</li> <li><math>I_{min}</math> AC/DC *</li> </ul>		48		V
		1		A
		5		mA
Power operation				
<ul style="list-style-type: none"> <li><math>U_{max}</math> AC *</li> <li><math>U_{min}</math> AC/DC *</li> <li><math>I_{max}</math> AC *</li> </ul>		250		V
		5		V
		5		A

## 3 | Device description

Electrical characteristics limit switch	min.	typ.	max.	unit
After one-off operation with $U > 24$ VAC/DC or $I > 100$ mA:				
• $U_{\min}$ AC/DC*		12		V
• $I_{\min}$ AC/DC*		100		mA
Environmental conditions	min.	typ.	max.	unit
Humidity (not condensing)			90	% rH
Protection class as per DIN EN 60529	IP66			
Operation				
• Ambient temperature (T6)	-40		+40	°C
• Ambient temperature (T5)	-40		+50	°C
Storage				
• Ambient temperature	-40		+70	°C

\*: Nominal value: please note that nominal values are also subject to tolerances. For more detailed information, see: ▶ *Note on nominal values [p.33]*

## 3.10.19 Max-15-BF-TR

Mechanical properties	min.	typ.	max.	unit
Motor torque*		15		Nm
Motor runtime for 90° (can be configured with rotary switch)*		3 15 30 60 120		s
Spring torque*		15		Nm
Spring return time for 90° (can be configured with rotary switch)*		3 / 10		s
Minimum angle of rotation*		-5		°
Maximum angle of rotation*		90		°
Weight* <ul style="list-style-type: none"> <li>• Max-15-BF-TR</li> </ul>		3.8		kg

Dimensions	min.	typ.	max.	unit
Max-15-BF-TR				
L	-1	210	+1	mm
W	-1	96	+1	mm
H	-1	80	+1	mm
Hollow shaft double square	12 × 12			mm
Allen key provided for manual adjustment in accordance with these instructions*		3		mm

Electrical characteristics	min.	typ.	max.	unit
Minimum nominal voltage (at room temperature)	-10 %	24	+10 %	VAC/DC
Maximum nominal voltage (at room temperature)	-10 %	240	+10 %	VAC/DC
Minimum mains frequency	-20 %	50	+20 %	Hz
Maximum mains frequency	-20 %	60	+20 %	Hz
Nominal current (at room temperature)	▶ Power consumption as a function of supply voltage [p.31]			
Power consumption standby*		5		W
Power consumption heating mode*		16		W
Power consumption in operation	▶ Power consumption as a function of supply voltage [p.31]			

## 3 | Device description

Electrical characteristics	min.	typ.	max.	unit
Switch-on peak				
<ul style="list-style-type: none"> <li>at 24 VDC (for approx. 2 seconds)*</li> <li>at 240 VDC (for approx. 2 seconds)*</li> </ul>		2		A
		2		A
Maximum duty cycle for motor run time*				
3 s		60 s enforced pause after 3 s motor operation		
15 s, 30 s, 60 s, 120 s		100		%

### Electrical connection options

► *1-wire with spring return with configurable spring return period BF [p.28]*

Cable type 11+PE, cable diameter 9.4 mm

► *3-point with spring return with configurable spring return period BF [p.29]*

Cable type 11+PE, cable diameter 9.4 mm

Electrical characteristics limit switch	min.	typ.	max.	unit
Switch point CLOSED	-2	5	+2	°
Switch point OPEN	-2	85	+2	°
Signal operation				
<ul style="list-style-type: none"> <li><math>U_{max}</math> DC*</li> <li><math>I_{max}</math> DC*</li> <li><math>I_{min}</math> AC/DC*</li> </ul>		48		V
		1		A
		5		mA
Power operation				
<ul style="list-style-type: none"> <li><math>U_{max}</math> AC*</li> <li><math>U_{min}</math> AC/DC*</li> <li><math>I_{max}</math> AC*</li> </ul>		250		V
		5		V
		5		A
After one-off operation with $U > 24$ VAC/DC or $I > 100$ mA:				
<ul style="list-style-type: none"> <li><math>U_{min}</math> AC/DC*</li> <li><math>I_{min}</math> AC/DC*</li> </ul>		12		V
		100		mA

Environmental conditions	min.	typ.	max.	unit
Humidity (not condensing)			90	% rH
Protection class as per DIN EN 60529	IP66			
Operation				

Environmental conditions	min.	typ.	max.	unit
<ul style="list-style-type: none"><li>Ambient temperature (T6)</li></ul>	-40		+40	°C
<ul style="list-style-type: none"><li>Ambient temperature (T5)</li></ul>	-40		+50	°C
Storage				
<ul style="list-style-type: none"><li>Ambient temperature</li></ul>	-40		+70	°C

\*: Nominal value: please note that nominal values are also subject to tolerances. For more detailed information, see: ▶ *Note on nominal values [p.33]*

## 3 | Device description

### 3.10.20 Max-15-CYF, Max-15-CYF-VAS

Mechanical properties	min.	typ.	max.	unit
Motor torque*		15		Nm
Motor runtime for 90° (can be configured with rotary switch)*		7.5 15 30 60 120		s
Spring torque*		15		Nm
Spring return time for 90° (can be configured with rotary switch)*		3 / 10		s
Minimum angle of rotation*		-5		°
Maximum angle of rotation*		90		°
Weight*				
<ul style="list-style-type: none"> <li>• Max-15-CYF</li> </ul>		3.8		kg
<ul style="list-style-type: none"> <li>• Max-15-CYF-VAS</li> </ul>		5.6		kg

Dimensions	min.	typ.	max.	unit
Max-15-CYF				
L	-1	210	+1	mm
W	-1	96	+1	mm
H	-1	80	+1	mm
Max-15-CYF-VAS				
L	-1	211	+1	mm
W	-1	96	+1	mm
H	-1	81	+1	mm
Hollow shaft double square	12 × 12			mm
Allen key provided for manual adjustment in accordance with these instructions*		3		mm

Electrical characteristics	min.	typ.	max.	unit
Minimum nominal voltage (at room temperature)	-10 %	24	+10 %	VAC/DC
Maximum nominal voltage (at room temperature)	-10 %	240	+10 %	VAC/DC
Minimum mains frequency	-20 %	50	+20 %	Hz
Maximum mains frequency	-20 %	60	+20 %	Hz
Power consumption standby*		5		W
Power consumption heating mode*		16		W

Electrical characteristics	min.	typ.	max.	unit
Power consumption in operation	▶ <i>Power consumption as a function of supply voltage [p.31]</i>			
Switch-on peak				
<ul style="list-style-type: none"> <li>at 24 VDC (for approx. 2 seconds)*</li> <li>at 240 VDC (for approx. 2 seconds)*</li> </ul>		2		A
		2		A
Maximum duty cycle for motor run time				
7.5 s, 15 s, 30 s, 60 s, 120 s	100			%

## Electrical connection options

▶ <i>1-wire with spring return continuous activation [p.28]</i>	Cable type 5+PE, cable diameter 7.5 mm
---	--

Activation CY-drives	min.	typ.	max.	unit
Power supply / frequency				
Minimum voltage	-10 %	24	+10 %	VAC/DC
Maximum voltage	-10 %	240	+10 %	VAC/DC
Minimum frequency	-20 %	50	+20 %	Hz
Maximum frequency	-20 %	60	+20 %	Hz
Activation Y	4		20	mA
Feedback signal U	0		10	VDC
Performance data Y and U				
<ul style="list-style-type: none"> <li>Activation <math>Y_U</math> (for 10 k<math>\Omega</math>)</li> <li>Feedback <math>U_U</math> (for 2000 k<math>\Omega</math>...<math>\infty</math> <math>\Omega</math>)</li> </ul>	0		10	VDC
	0		10	VDC

Environmental conditions	min.	typ.	max.	unit
Humidity (not condensing)			90	% rH
Protection class as per DIN EN 60529	IP66			
Operation				
<ul style="list-style-type: none"> <li>Ambient temperature (T6)</li> <li>Ambient temperature (T5)</li> </ul>	-40		+40	°C
	-40		+50	°C
Storage				
<ul style="list-style-type: none"> <li>Ambient temperature</li> </ul>	-40		+70	°C

\*: Nominal value: please note that nominal values are also subject to tolerances. For more detailed information, see: ▶ *Note on nominal values [p.33]*

## 3.10.21 Max-15.30, Max-15.30-CTS, Max-15.30-VAS

Mechanical properties	min.	typ.	max.	unit
Motor torque (can be configured with rotary switch)*		15 / 30		Nm
Motor runtime for 90° (can be configured with rotary switch)*		3 15 30 60 120		s
Minimum angle of rotation*		-5		°
Maximum angle of rotation*		90		°
Weight* <ul style="list-style-type: none"> <li>• Max-15.30</li> <li>• Max-15.30-CTS</li> <li>• Max-15.30-VAS</li> </ul>		3.5 3.5 5.3		kg kg kg

Dimensions	min.	typ.	max.	unit
Max-15.30				
L	-1	210	+1	mm
W	-1	96	+1	mm
H	-1	80	+1	mm
Max-15.30-CTS				
L	-1	210	+1	mm
W	-1	96	+1	mm
H	-1	80	+1	mm
Max-15.30-VAS				
L	-1	211	+1	mm
W	-1	96	+1	mm
H	-1	81	+1	mm
Hollow shaft double square	12 × 12			mm
Allen key provided for manual adjustment in accordance with these instructions*		3		mm

Electrical characteristics	min.	typ.	max.	unit
Minimum nominal voltage (at room temperature)	-10 %	24	+10 %	VAC/DC
Maximum nominal voltage (at room temperature)	-10 %	240	+10 %	VAC/DC
Minimum mains frequency	-20 %	50	+20 %	Hz
Maximum mains frequency	-20 %	60	+20 %	Hz



Electrical characteristics	min.	typ.	max.	unit
Nominal current (at room temperature)	▶ <i>Power consumption as a function of supply voltage [p.31]</i>			
Power consumption standby*		5		W
Power consumption heating mode*		16		W
Power consumption in operation	▶ <i>Power consumption as a function of supply voltage [p.31]</i>			
Switch-on peak				
<ul style="list-style-type: none"> <li>at 24 VDC (for approx. 2 seconds)*</li> <li>at 240 VDC (for approx. 2 seconds)*</li> </ul>		2		A
		2		A
Maximum duty cycle for motor run time*	60 s enforced pause after 3 s motor operation			
3 s				
15 s, 30 s, 60 s, 120 s	100			%

### Electrical connection options

▶ *3-point no spring return [p.20]*

Cable type 4+PE, cable diameter 7.2 mm

Environmental conditions	min.	typ.	max.	unit
Humidity (not condensing)			90	% rH
Protection class as per DIN EN 60529	IP66			
Operation				
<ul style="list-style-type: none"> <li>Ambient temperature (T6)</li> </ul>	-40		+40	°C
<ul style="list-style-type: none"> <li>Ambient temperature (T5)</li> </ul>	-40		+50	°C
Storage				
<ul style="list-style-type: none"> <li>Ambient temperature</li> </ul>	-40		+70	°C

\*: Nominal value: please note that nominal values are also subject to tolerances. For more detailed information, see: ▶ *Note on nominal values [p.33]*

## 3.10.22 Max-15.30-Y, Max-15.30-Y-CTS, Max-15.30-Y-VAS

Mechanical properties	min.	typ.	max.	unit
Motor torque (can be configured with rotary switch)*		15 / 30		Nm
Motor runtime for 90° (can be configured with rotary switch)*		7.5 15 30 60 120		s
Minimum angle of rotation*		-5		°
Maximum angle of rotation*		90		°
Weight* <ul style="list-style-type: none"> <li>• Max-15.30-Y</li> <li>• Max-15.30-Y-CTS</li> <li>• Max-15.30-Y-VAS</li> </ul>		3.5 3.5 5.3		kg kg kg

Dimensions	min.	typ.	max.	unit
Max-15.30-Y				
L	-1	210	+1	mm
W	-1	96	+1	mm
H	-1	80	+1	mm
Max-15.30-Y-CTS				
L	-1	210	+1	mm
W	-1	96	+1	mm
H	-1	80	+1	mm
Max-15.30-Y-VAS				
L	-1	211	+1	mm
W	-1	96	+1	mm
H	-1	81	+1	mm
Hollow shaft double square	12 × 12			mm
Allen key provided for manual adjustment in accordance with these instructions*		3		mm

Electrical characteristics	min.	typ.	max.	unit
Minimum nominal voltage (at room temperature)	-10 %	24	+10 %	VAC/DC
Maximum nominal voltage (at room temperature)	-10 %	240	+10 %	VAC/DC
Minimum mains frequency	-20 %	50	+20 %	Hz
Maximum mains frequency	-20 %	60	+20 %	Hz

Electrical characteristics	min.	typ.	max.	unit
Nominal current (at room temperature)	▶ Power consumption as a function of supply voltage [p.31]			
Power consumption standby*		5		W
Power consumption heating mode*		16		W
Power consumption in operation	▶ Power consumption as a function of supply voltage [p.31]			
Switch-on peak				
<ul style="list-style-type: none"> <li>at 24 VDC (for approx. 2 seconds)*</li> <li>at 240 VDC (for approx. 2 seconds)*</li> </ul>		2		A
		2		A
Maximum duty cycle for motor run time	7.5 s, 15 s, 30 s, 60 s, 120 s			100
				%

Electrical connection options	
▶ 3-point with spring return with configurable spring return period continuous [p.25]	Cable type 5+PE, cable diameter 7.5 mm / cable type 6, cable diameter 7.4 mm
▶ 1-wire with spring return with configurable spring return period continuous [p.26]	Cable type 5+PE, cable diameter 7.5 mm / cable type 6, cable diameter 7.4 mm
▶ 1-wire with spring return continuous without feedback signal [p.26]	Cable type 5+PE, cable diameter 7.5 mm / cable type 6, cable diameter 7.4 mm
▶ 3-point with spring return with configurable spring return period continuous feedback signal [p.27]	Cable type 5+PE, cable diameter 7.5 mm / cable type 6, cable diameter 7.4 mm

Activation CONTROL	min.	typ.	max.	unit
Angle of rotation and position indicator		95		°
Precision electrical*		~100		Step
Activation Y	0		10	VDC
	4		20	mA
Performance data Y and U				
<ul style="list-style-type: none"> <li>Activation <math>Y_U</math> (for 10 k<math>\Omega</math> output impedance)</li> <li>Activation <math>Y_I</math> (for 100 <math>\Omega</math> load / output impedance)</li> <li>Feedback <math>U_U</math> (for 10 k<math>\Omega</math>...<math>\infty</math> <math>\Omega</math> input impedance)</li> <li>Feedback <math>U_I</math> (for 0...800 <math>\Omega</math> load / input impedance)</li> </ul>	0		10	VDC
	4		20	mA
	0		10	VDC
	4		20	mA

## 3 | Device description

<b>Activation CONTROL</b>	<b>min.</b>	<b>typ.</b>	<b>max.</b>	<b>unit</b>
Inverting	Setting up wire bridges between terminals 3 and 4			
<b>Environmental conditions</b>	<b>min.</b>	<b>typ.</b>	<b>max.</b>	<b>unit</b>
Humidity (not condensing)			90	% rH
Protection class as per DIN EN 60529	IP66			
Operation				
• Ambient temperature (T6)	-40		+40	°C
• Ambient temperature (T5)	-40		+50	°C
Storage				
• Ambient temperature	-40		+70	°C

\*: Nominal value: please note that nominal values are also subject to tolerances. For more detailed information, see: ▶ *Note on nominal values [p.33]*

## 3.10.23 Max-15.30-S, Max-15.30-S-CTS, Max-15.30-S-VAS

Mechanical properties	min.	typ.	max.	unit
Motor torque (can be configured with rotary switch)*		15 / 30		Nm
Motor runtime for 90° (can be configured with rotary switch)*		3 15 30 60 120		s
Minimum angle of rotation*		-5		°
Maximum angle of rotation*		90		°
Weight* <ul style="list-style-type: none"> <li>• Max-15.30-S</li> <li>• Max-15.30-S-CTS</li> <li>• Max-15.30-S-VAS</li> </ul>		3.5 3.5 5.3		kg kg kg

Dimensions	min.	typ.	max.	unit
Max-15.30-S				
L	-1	210	+1	mm
W	-1	96	+1	mm
H	-1	80	+1	mm
Max-15.30-S-CTS				
L	-1	210	+1	mm
W	-1	96	+1	mm
H	-1	80	+1	mm
Max-15.30-S-VAS				
L	-1	211	+1	mm
W	-1	96	+1	mm
H	-1	81	+1	mm
Hollow shaft double square	12 × 12			mm
Allen key provided for manual adjustment in accordance with these instructions*		3		mm

Electrical characteristics	min.	typ.	max.	unit
Minimum nominal voltage (at room temperature)	-10 %	24	+10 %	VAC/DC
Maximum nominal voltage (at room temperature)	-10 %	240	+10 %	VAC/DC
Minimum mains frequency	-20 %	50	+20 %	Hz
Maximum mains frequency	-20 %	60	+20 %	Hz

## 3 | Device description

Electrical characteristics	min.	typ.	max.	unit
Nominal current (at room temperature)	▶ Power consumption as a function of supply voltage [p.31]			
Power consumption standby*		5		W
Power consumption heating mode*		16		W
Power consumption in operation	▶ Power consumption as a function of supply voltage [p.31]			
Switch-on peak				
• at 24 VDC (for approx. 2 seconds)*		2		A
• at 240 VDC (for approx. 2 seconds)*		2		A
Maximum duty cycle for motor run time*	60 s enforced pause after 3 s motor operation			
3 s				
15 s, 30 s, 60 s, 120 s	100			%

### Electrical connection options

▶ 3-point no spring return [p.20]	Cable type 4+PE, cable diameter 7.2 mm
▶ Integrated limit switch [p.23]	Cable type 6, cable diameter 7.4 mm

Electrical characteristics limit switch	min.	typ.	max.	unit
Switch point CLOSED	-2	5	+2	°
Switch point OPEN	-2	85	+2	°
Signal operation				
• $U_{max}$ DC*		48		V
• $I_{max}$ DC*		1		A
• $I_{min}$ AC/DC*		5		mA
Power operation				
• $U_{max}$ AC*		250		V
• $U_{min}$ AC/DC*		5		V
• $I_{max}$ AC*		5		A
After one-off operation with $U > 24$ VAC/DC or $I > 100$ mA:				
• $U_{min}$ AC/DC*		12		V
• $I_{min}$ AC/DC*		100		mA

<b>Environmental conditions</b>	<b>min.</b>	<b>typ.</b>	<b>max.</b>	<b>unit</b>
Humidity (not condensing)			90	% rH
Protection class as per DIN EN 60529	IP66			
Operation				
• Ambient temperature (T6)	-40		+40	°C
• Ambient temperature (T5)	-40		+50	°C
Storage				
• Ambient temperature	-40		+70	°C

\*: Nominal value: please note that nominal values are also subject to tolerances. For more detailed information, see: ▶ *Note on nominal values [p.33]*

## 3.10.24 Max-15.30-R, Max-15.30-R-CTS, Max-15.30-R-VAS

Mechanical properties	min.	typ.	max.	unit
Motor torque (can be configured with rotary switch)*		15 / 30		Nm
Motor runtime for 360° (can be configured with rotary switch)*		60 120 240 480		s
Angle of rotation*		rotary		
Weight* <ul style="list-style-type: none"> <li>• Max-15.30-R</li> <li>• Max-15.30-R-CTS</li> <li>• Max-15.30-R-VAS</li> </ul>		3.5 3.5 5.3		kg kg kg

Dimensions	min.	typ.	max.	unit
Max-15.30-R				
L	-1	210	+1	mm
W	-1	96	+1	mm
H	-1	80	+1	mm
Max-15.30-R-CTS				
L	-1	210	+1	mm
W	-1	96	+1	mm
H	-1	80	+1	mm
Max-15.30-R-VAS				
L	-1	211	+1	mm
W	-1	96	+1	mm
H	-1	81	+1	mm
Hollow shaft double square	12 × 12			mm
Allen key provided for manual adjustment in accordance with these instructions*		3		mm

Electrical characteristics	min.	typ.	max.	unit
Minimum nominal voltage (at room temperature)	-10 %	24	+10 %	VAC/DC
Maximum nominal voltage (at room temperature)	-10 %	240	+10 %	VAC/DC
Minimum mains frequency	-20 %	50	+20 %	Hz
Maximum mains frequency	-20 %	60	+20 %	Hz
Nominal current (at room temperature)	▶ Power consumption as a function of supply voltage [p.31]			



Electrical characteristics	min.	typ.	max.	unit
Power consumption standby*		5		W
Power consumption heating mode*		16		W
Power consumption in operation	▶ <i>Power consumption as a function of supply voltage [p.31]</i>			
Switch-on peak				
<ul style="list-style-type: none"> <li>at 24 VDC (for approx. 2 seconds)*</li> <li>at 240 VDC (for approx. 2 seconds)*</li> </ul>		2		A
		2		A
Maximum duty cycle for motor operation*	100			%

Electrical connection options	
▶ <i>3-point no spring return [p.20]</i>	Cable type 4+PE, cable diameter 7.2 mm

Environmental conditions	min.	typ.	max.	unit
Humidity (not condensing)			90	% rH
Protection class as per DIN EN 60529	IP66			
Operation				
<ul style="list-style-type: none"> <li>Ambient temperature (T6)</li> <li>Ambient temperature (T5)</li> </ul>	-40		+40	°C
	-40		+50	°C
Storage				
<ul style="list-style-type: none"> <li>Ambient temperature</li> </ul>	-40		+70	°C

\*: Nominal value: please note that nominal values are also subject to tolerances. For more detailed information, see: ▶ *Note on nominal values [p.33]*

## 3 | Device description

### 3.10.25 Max-15.30-CY

Mechanical properties	min.	typ.	max.	unit
Motor torque (can be configured with rotary switch)*		15 / 30		Nm
Motor runtime for 90° (can be configured with rotary switch)*		7.5 15 30 60 120		s
Minimum angle of rotation*		-5		°
Maximum angle of rotation*		90		°
Weight* <ul style="list-style-type: none"> <li>Max-15.30-CY</li> </ul>		3.5		kg

Dimensions	min.	typ.	max.	unit
Max-15.30-CY				
L	-1	210	+1	mm
W	-1	96	+1	mm
H	-1	80	+1	mm
Hollow shaft double square	12 × 12			mm
Allen key provided for manual adjustment in accordance with these instructions*		3		mm

Electrical characteristics	min.	typ.	max.	unit
Minimum nominal voltage (at room temperature)	-10 %	24	+10 %	VAC/DC
Maximum nominal voltage (at room temperature)	-10 %	240	+10 %	VAC/DC
Minimum mains frequency	-20 %	50	+20 %	Hz
Maximum mains frequency	-20 %	60	+20 %	Hz
Power consumption standby*		5		W
Power consumption heating mode*		16		W
Power consumption in operation	▶ Power consumption as a function of supply voltage [p.31]			
Switch-on peak <ul style="list-style-type: none"> <li>at 24 VDC (for approx. 2 seconds)*</li> <li>at 240 VDC (for approx. 2 seconds)*</li> </ul>		2 2		A A
Maximum duty cycle for motor run time 7.5 s, 15 s, 30 s, 60 s, 120 s		100		%

## Electrical connection options

▶ <i>Without spring return continuous activation [p.27]</i>	Cable type 5+PE, cable diameter 7.5 mm
---	--

Activation CY-drives	min.	typ.	max.	unit
Power supply / frequency				
Minimum voltage	-10 %	24	+10 %	VAC/DC
Maximum voltage	-10 %	240	+10 %	VAC/DC
Minimum frequency	-20 %	50	+20 %	Hz
Maximum frequency	-20 %	60	+20 %	Hz
Activation Y	4		20	mA
Feedback signal U	0		10	VDC
Performance data Y and U				
• Activation $Y_U$ (for 10 k $\Omega$ )	0		10	VDC
• Feedback $U_U$ (for 2000 k $\Omega$ ... $\infty$ $\Omega$ )	0		10	VDC

Environmental conditions	min.	typ.	max.	unit
Humidity (not condensing)			90	% rH
Protection class as per DIN EN 60529	IP66			
Operation				
• Ambient temperature (T6)	-40		+40	°C
• Ambient temperature (T5)	-40		+50	°C
Storage				
• Ambient temperature	-40		+70	°C

\*: Nominal value: please note that nominal values are also subject to tolerances. For more detailed information, see: ▶ *Note on nominal values [p.33]*

## 3.10.26 Max-8-F1, Max-8-F1-CTS, Max-8-F1-VAS

Mechanical properties	min.	typ.	max.	unit
Motor torque*		8		Nm
Motor runtime for 90° (can be configured with rotary switch)*		3 15 30 60 120		s
Spring torque*		6		Nm
Spring return time for 90° (can be configured with rotary switch) (The spring return time can vary at low temperatures. For further information, please contact our sales staff.)*		~1		s
Load torque, value must not be below this	2			Nm
Minimum angle of rotation*		-5		°
Maximum angle of rotation*		90		°
Weight* <ul style="list-style-type: none"> <li>• Max-8-F1</li> <li>• Max-8-F-CTS</li> <li>• Max-8-F1-VAS</li> </ul>		4.0 4.0 5.6		kg kg kg

Dimensions	min.	typ.	max.	unit
Max-8-F1				
L	-1	210	+1	mm
W	-1	96	+1	mm
H	-1	80	+1	mm
Max-8-F-CTS				
L	-1	210	+1	mm
W	-1	96	+1	mm
H	-1	80	+1	mm
Max-8-F1-VAS				
L	-1	211	+1	mm
W	-1	96	+1	mm
H	-1	81	+1	mm
Hollow shaft double square	12 × 12			mm
Allen key provided for manual adjustment in accordance with these instructions*		3		mm

Electrical characteristics	min.	typ.	max.	unit
Minimum nominal voltage (at room temperature)	-10 %	24	+10 %	VAC/DC
Maximum nominal voltage (at room temperature)	-10 %	240	+10 %	VAC/DC
Minimum mains frequency	-20 %	50	+20 %	Hz
Maximum mains frequency	-20 %	60	+20 %	Hz
Nominal current (at room temperature)	► <i>Power consumption as a function of supply voltage [p.31]</i>			
Power consumption standby*		5		W
Power consumption heating mode*		16		W
Power consumption in operation	► <i>Power consumption as a function of supply voltage [p.31]</i>			
Switch-on peak				
<ul style="list-style-type: none"> <li>at 24 VDC (for approx. 2 seconds)*</li> <li>at 240 VDC (for approx. 2 seconds)*</li> </ul>		2		A
		2		A
Maximum duty cycle for motor run time*	60 s enforced pause after 3 s motor operation			
3 s				
15 s, 30 s, 60 s, 120 s	100			%

## Electrical connection options

► <i>2-wire with spring return constant spring return period [p.22]</i>	Cable type 3+PE, cable diameter 6.0 mm
► <i>1-wire with spring return constant spring return period [p.23]</i>	Cable type 3+PE, cable diameter 6.0 mm

Ambient conditions	min.	typ.	max.	unit
Humidity (non-condensing)			90	% rH
Degree of protection to EN 60529	IP66			
Operation				
<ul style="list-style-type: none"> <li>Ambient temperature (T6)</li> <li>Ambient temperature (T5)</li> </ul>	-20		+40	°C
	-20		+50	°C
Storage				
<ul style="list-style-type: none"> <li>Ambient temperature</li> </ul>	-40		+70	°C

\*: Nominal value: please note that nominal values are also subject to tolerances. For more detailed information, see: ► *Note on nominal values [p.33]*

## 3.10.27 Max-8-SF1, Max-8-SF1-CTS, Max-8-SF1-VAS

Mechanical properties	min.	typ.	max.	unit
Motor torque*		8		Nm
Motor runtime for 90° (can be configured with rotary switch)*		3 15 30 60 120		s
Spring torque*		6		Nm
Spring return time for 90° (can be configured with rotary switch) (The spring return time can vary at low temperatures. For further information, please contact our sales staff.)*		~1		s
Load torque, value must not be below this	2			Nm
Minimum angle of rotation*		-5		°
Maximum angle of rotation*		90		°
Weight* <ul style="list-style-type: none"> <li>• Max-8-SF1</li> <li>• Max-8-SF1-CTS</li> <li>• Max-8-SF1-VAS</li> </ul>		4.0 4.0 5.6		kg kg kg

Dimensions	min.	typ.	max.	unit
Max-8-SF1				
L	-1	210	+1	mm
W	-1	96	+1	mm
H	-1	80	+1	mm
Max-8-SF1-CTS				
L	-1	210	+1	mm
W	-1	96	+1	mm
H	-1	80	+1	mm
Max-8-SF1-VAS				
L	-1	211	+1	mm
W	-1	96	+1	mm
H	-1	81	+1	mm
Hollow shaft double square	12 × 12			mm
Allen key provided for manual adjustment in accordance with these instructions*		3		mm

Electrical characteristics	min.	typ.	max.	unit
Minimum nominal voltage (at room temperature)	-10 %	24	+10 %	VAC/DC
Maximum nominal voltage (at room temperature)	-10 %	240	+10 %	VAC/DC
Minimum mains frequency	-20 %	50	+20 %	Hz
Maximum mains frequency	-20 %	60	+20 %	Hz
Nominal current (at room temperature)	▶ Power consumption as a function of supply voltage [p.31]			
Power consumption standby*		5		W
Power consumption heating mode*		16		W
Power consumption in operation	▶ Power consumption as a function of supply voltage [p.31]			
Switch-on peak				
<ul style="list-style-type: none"> <li>at 24 VDC (for approx. 2 seconds)*</li> <li>at 240 VDC (for approx. 2 seconds)*</li> </ul>		2		A
		2		A
Maximum duty cycle for motor run time*	60 s enforced pause after 3 s motor operation			
3 s				
15 s, 30 s, 60 s, 120 s	100			%

## Electrical connection options

▶ 2-wire with spring return constant spring return period [p.22]	Cable type 3+PE, cable diameter 6.0 mm
▶ 1-wire with spring return constant spring return period [p.23]	Cable type 3+PE, cable diameter 6.0 mm
▶ Integrated limit switch [p.24]	Cable type 6, cable diameter 7.4 mm

Electrical characteristics limit switch	min.	typ.	max.	unit
Switch point CLOSED	-2	5	+2	°
Switch point OPEN	-2	85	+2	°
Signal operation				
<ul style="list-style-type: none"> <li><math>U_{max}</math> DC*</li> <li><math>I_{max}</math> DC*</li> <li><math>I_{min}</math> AC/DC*</li> </ul>		48		V
		1		A
		5		mA

## 3 | Device description

Electrical characteristics limit switch	min.	typ.	max.	unit
Power operation				
• $U_{max}$ AC*		250		V
• $U_{min}$ AC/DC*		5		V
• $I_{max}$ AC*		5		A
After one-off operation with $U > 24$ VAC/DC or $I > 100$ mA:				
• $U_{min}$ AC/DC*		12		V
• $I_{min}$ AC/DC*		100		mA
Ambient conditions	min.	typ.	max.	unit
Humidity (non-condensing)			90	% rH
Degree of protection to EN 60529	IP66			
Operation				
• Ambient temperature (T6)	-20		+40	°C
• Ambient temperature (T5)	-20		+50	°C
Storage				
• Ambient temperature	-40		+70	°C

\*: Nominal value: please note that nominal values are also subject to tolerances. For more detailed information, see: ▶ *Note on nominal values [p.33]*



## 3.10.28 Max-8-BF1, Max-8-BF1-CTS, Max-8-BF1-VAS

Mechanical properties	min.	typ.	max.	unit
Motor torque*		8		Nm
Motor runtime for 90° (can be configured with rotary switch)*		3 15 30 60 120		s
Spring torque*		5		Nm
Spring return time for 90° (can be configured with rotary switch) (The spring return time can vary at low temperatures. For further information, please contact our sales staff.)*		~1		s
Load torque, value must not be below this	2			Nm
Minimum angle of rotation*		-5		°
Maximum angle of rotation*		90		°
Weight* <ul style="list-style-type: none"> <li>• Max-8-BF1</li> <li>• Max-8-BF1-CTS</li> <li>• Max-8-BF1-VAS</li> </ul>		4.0 4.0 5.6		kg kg kg
Dimensions	min.	typ.	max.	unit
Max-8-BF1				
L	-1	210	+1	mm
W	-1	96	+1	mm
H	-1	80	+1	mm
Max-8-BF1-CTS				
L	-1	210	+1	mm
W	-1	96	+1	mm
H	-1	80	+1	mm
Max-8-BF1-VAS				
L	-1	211	+1	mm
W	-1	96	+1	mm
H	-1	81	+1	mm
Hollow shaft double square	12 × 12			mm
Allen key provided for manual adjustment in accordance with these instructions*		3		mm

## 3 | Device description

Electrical characteristics	min.	typ.	max.	unit
Minimum nominal voltage (at room temperature)	-10 %	24	+10 %	VAC/DC
Maximum nominal voltage (at room temperature)	-10 %	240	+10 %	VAC/DC
Minimum mains frequency	-20 %	50	+20 %	Hz
Maximum mains frequency	-20 %	60	+20 %	Hz
Nominal current (at room temperature)	▶ Power consumption as a function of supply voltage [p.31]			
Power consumption standby*		5		W
Power consumption heating mode*		16		W
Power consumption in operation	▶ Power consumption as a function of supply voltage [p.31]			
Switch-on peak				
<ul style="list-style-type: none"> <li>at 24 VDC (for approx. 2 seconds)*</li> <li>at 240 VDC (for approx. 2 seconds)*</li> </ul>		2		A
		2		A
Maximum duty cycle for motor run time*				
3 s	60 s enforced pause after 3 s motor operation			
15 s, 30 s, 60 s, 120 s	100			%

### Electrical connection options

▶ 2-wire with spring return constant spring return period [p.22]	Cable type 3+PE, cable diameter 6.0 mm
▶ 1-wire with spring return constant spring return period [p.23]	Cable type 3+PE, cable diameter 6.0 mm
▶ 1-wire with spring return constant spring return period BF1/ BF3 [p.30]	Cable type 9+PE, cable diameter 8.8 mm

Electrical characteristics limit switch	min.	typ.	max.	unit
Switch point CLOSED	-2	5	+2	°
Switch point OPEN	-2	85	+2	°
Signal operation				
<ul style="list-style-type: none"> <li><math>U_{max}</math> DC*</li> <li><math>I_{max}</math> DC*</li> <li><math>I_{min}</math> AC/DC*</li> </ul>		48		V
		1		A
		5		mA

Electrical characteristics limit switch	min.	typ.	max.	unit
Power operation				
• $U_{\max}$ AC*		250		V
• $U_{\min}$ AC/DC*		5		V
• $I_{\max}$ AC*		5		A
After one-off operation with $U > 24$ VAC/DC or $I > 100$ mA:				
• $U_{\min}$ AC/DC*		12		V
• $I_{\min}$ AC/DC*		100		mA
Ambient conditions	min.	typ.	max.	unit
Humidity (non-condensing)			90	% rH
Degree of protection to EN 60529	IP66			
Operation				
• Ambient temperature (T6)	-20		+40	°C
• Ambient temperature (T5)	-20		+50	°C
Storage				
• Ambient temperature	-40		+70	°C

\*: Nominal value: please note that nominal values are also subject to tolerances. For more detailed information, see: ▶ *Note on nominal values [p.33]*

## 3 | Device description

### 3.10.29 Max-30-BF, Max-30-BF-CTM

Mechanical properties	min.	typ.	max.	unit
Motor torque*		30		Nm
Motor runtime for 90° (can be configured with rotary switch)*		40 60 90 120 150		s
Spring torque*		30		Nm
Spring return period for 90°*		20		s
Minimum angle of rotation*		-5		°
Maximum angle of rotation*		90		°
Weight* <ul style="list-style-type: none"> <li>• Max-30-BF</li> <li>• Max-30-BF-CTM</li> </ul>		9.5 9.5		kg kg

Dimensions	min.	typ.	max.	unit
Max-30-BF				
L	-1	288	+1	mm
W	-1	149	+1	mm
H	-1	116	+1	mm
Max-30-BF-CTM				
L	-1	288	+1	mm
W	-1	149	+1	mm
H	-1	116	+1	mm
Hollow shaft double square	16 x 16			mm
Allen key provided for manual adjustment in accordance with these instructions*		4		mm

Electrical characteristics	min.	typ.	max.	unit
Minimum nominal voltage (at room temperature)	-10 %	24	+10 %	VAC/DC
Maximum nominal voltage (at room temperature)	-10 %	240	+10 %	VAC/DC
Minimum mains frequency	-20 %	50	+20 %	Hz
Maximum mains frequency	-20 %	60	+20 %	Hz
Nominal current (at room temperature)	▶ <i>Nominal current [p.31]</i>			
Power consumption standby*		5		W

Electrical characteristics	min.	typ.	max.	unit
Power consumption heating mode*		16		W
Power consumption in operation	▶ <i>Nominal current [p.31]</i>			
Switch-on peak				
<ul style="list-style-type: none"> <li>at 24 VDC (for approx. 2 seconds)*</li> <li>at 240 VDC (for approx. 2 seconds)*</li> </ul>		2		A
		2		A
Maximum duty cycle for motor run time*				
40 s, 60 s, 90 s, 120 s, 150 s		100		%

Electrical connection options	
▶ <i>1-wire with spring return with constant spring return period BF [p.29]</i>	Cable type 10+PE, cable diameter 9.4 mm
▶ <i>3-point with spring return with constant spring return period BF [p.30]</i>	Cable type 10+PE, cable diameter 9.4 mm

Electrical characteristics limit switch	min.	typ.	max.	unit
Switch point CLOSED	-2	5	+2	°
Switch point OPENED	-2	85	+2	°
Signal operation				
<ul style="list-style-type: none"> <li><math>U_{max}</math> DC*</li> <li><math>I_{max}</math> DC*</li> <li><math>I_{min}</math> AC/DC*</li> </ul>		48		V
		1		A
		5		mA
Power operation				
<ul style="list-style-type: none"> <li><math>U_{max}</math> AC*</li> <li><math>U_{min}</math> AC/DC*</li> <li><math>I_{max}</math> AC*</li> </ul>		250		V
		5		V
		5		A
After one-off operation with $U > 24$ VAC/DC or $I > 100$ mA:				
<ul style="list-style-type: none"> <li><math>U_{min}</math> AC/DC*</li> <li><math>I_{min}</math> AC/DC*</li> </ul>		12		V
		100		mA

Environmental conditions	min.	typ.	max.	unit
Humidity (not condensing)			90	% rH
Protection class as per DIN EN 60529	IP67			
Operation				

## 3 | Device description

<b>Environmental conditions</b>	<b>min.</b>	<b>typ.</b>	<b>max.</b>	<b>unit</b>
• Ambient temperature (T6)	-40		+40	°C
• Ambient temperature (T5)	-40		+50	°C
Storage				
• Ambient temperature	-40		+70	°C

\*: Nominal value: please note that nominal values are also subject to tolerances. For more detailed information, see: ▶ *Note on nominal values [p.33]*

## 3.10.30 Max-30-BF3, Max-30-BF3-CTM

Mechanical properties	min.	typ.	max.	unit
Motor torque*		30		Nm
Motor runtime for 90° (can be configured with rotary switch)*		40 60 90 120 150		s
Spring torque*		24		Nm
Spring return period for 90° (The spring return time can vary at low temperatures. For further information, please contact our sales staff.)*		~3		s
Load torque, value must not be below this	8			Nm
Minimum angle of rotation*		-5		°
Maximum angle of rotation*		90		°
Weight* <ul style="list-style-type: none"> <li>• Max-30-BF3</li> <li>• Max-30-BF3-CTM</li> </ul>		9.5 9.5		kg kg

Dimensions	min.	typ.	max.	unit
Max-30-BF3				
L	-1	288	+1	mm
W	-1	149	+1	mm
H	-1	116	+1	mm
Max-30-BF3-CTM				
L	-1	288	+1	mm
W	-1	149	+1	mm
H	-1	116	+1	mm
Hollow shaft double square	16 × 16			mm
Allen key provided for manual adjustment in accordance with these instructions*		4		mm

Electrical characteristics	min.	typ.	max.	unit
Minimum nominal voltage (at room temperature)	-10 %	24	+10 %	VAC/DC
Maximum nominal voltage (at room temperature)	-10 %	240	+10 %	VAC/DC
Minimum mains frequency	-20 %	50	+20 %	Hz
Maximum mains frequency	-20 %	60	+20 %	Hz

## 3 | Device description

Electrical characteristics	min.	typ.	max.	unit
Nominal current (at room temperature)	▶ <i>Nominal current [p.31]</i>			
Power consumption standby*		5		W
Power consumption heating mode*		16		W
Power consumption in operation	▶ <i>Nominal current [p.31]</i>			
Switch-on peak				
• at 24 VDC (for approx. 2 seconds)*		2		A
• at 240 VDC (for approx. 2 seconds)*		2		A
Maximum duty cycle for motor run time*				
40 s, 60 s, 90 s, 120 s, 150 s		100		%

Electrical connection options	
▶ <i>2-wire with spring return constant spring return period [p.22]</i>	Cable type 3+PE, cable diameter 6.0 mm
▶ <i>1-wire with spring return constant spring return period [p.23]</i>	Cable type 3+PE, cable diameter 6.0 mm
▶ <i>1-wire with spring return constant spring return period BF1/BF3 [p.30]</i>	Cable type 9+PE, cable diameter 8.8 mm

Electrical characteristics limit switch	min.	typ.	max.	unit
Switch point CLOSED	-2	5	+2	°
Switch point OPENED	-2	85	+2	°
Signal operation				
• $U_{max}$ DC*		48		V
• $I_{max}$ DC*		1		A
• $I_{min}$ AC/DC*		5		mA
Power operation				
• $U_{max}$ AC*		250		V
• $U_{min}$ AC/DC*		5		V
• $I_{max}$ AC*		5		A
After one-off operation with $U > 24$ VAC/DC or $I > 100$ mA:				
• $U_{min}$ AC/DC*		12		V
• $I_{min}$ AC/DC*		100		mA



<b>Ambient conditions</b>	<b>min.</b>	<b>typ.</b>	<b>max.</b>	<b>unit</b>
Humidity (non-condensing)			90	% rH
Degree of protection to EN 60529	IP67			
Operation				
• Ambient temperature (T6)	-20		+40	°C
• Ambient temperature (T5)	-20		+50	°C
Storage				
• Ambient temperature	-40		+70	°C

\*: Nominal value: please note that nominal values are also subject to tolerances. For more detailed information, see: ▶ *Note on nominal values [p.33]*

## 3.10.31 Max-30-F, Max-30-F-CTM

Mechanical properties	min.	typ.	max.	unit
Motor torque*		30		Nm
Motor runtime for 90° (can be configured with rotary switch)*		40 60 90 120 150		s
Spring torque*		30		Nm
Spring return period for 90°*		20		s
Minimum angle of rotation*		-5		°
Maximum angle of rotation*		90		°
Weight*				
<ul style="list-style-type: none"> <li>Max-30-F</li> </ul>		9.5		kg
<ul style="list-style-type: none"> <li>Max-30-F-CTM</li> </ul>		9.5		kg

Dimensions	min.	typ.	max.	unit
Max-30-F				
L	-1	288	+1	mm
W	-1	149	+1	mm
H	-1	116	+1	mm
Max-30-F-CTM				
L	-1	288	+1	mm
W	-1	149	+1	mm
H	-1	116	+1	mm
Hollow shaft double square	16 × 16			mm
Allen key provided for manual adjustment in accordance with these instructions*		4		mm

Electrical characteristics	min.	typ.	max.	unit
Minimum nominal voltage (at room temperature)	-10 %	24	+10 %	VAC/DC
Maximum nominal voltage (at room temperature)	-10 %	240	+10 %	VAC/DC
Minimum mains frequency	-20 %	50	+20 %	Hz
Maximum mains frequency	-20 %	60	+20 %	Hz
Nominal current (at room temperature)	▶ Nominal current [p.31]			

Electrical characteristics	min.	typ.	max.	unit
Power consumption standby*		5		W
Power consumption heating mode*		16		W
Power consumption in operation	▶ <i>Nominal current [p.31]</i>			
Switch-on peak				
<ul style="list-style-type: none"> <li>at 24 VDC (for approx. 2 seconds)*</li> <li>at 240 VDC (for approx. 2 seconds)*</li> </ul>		2		A
		2		A
Maximum duty cycle for motor run time*				
40 s, 60 s, 90 s, 120 s, 150 s		100		%

Electrical connection options	
▶ <i>3-point with spring return constant spring return period [p.21]</i>	Cable type 4+PE, cable diameter 7.2 mm
▶ <i>1-wire with spring return constant spring return period [p.22]</i>	Cable type 4+PE, cable diameter 7.2 mm

Environmental conditions	min.	typ.	max.	unit
Humidity (not condensing)			90	% rH
Protection class as per DIN EN 60529	IP67			
Operation				
<ul style="list-style-type: none"> <li>Ambient temperature (T6)</li> <li>Ambient temperature (T5)</li> </ul>	-40		+40	°C
	-40		+50	°C
Storage				
<ul style="list-style-type: none"> <li>Ambient temperature</li> </ul>	-40		+70	°C

\*: Nominal value: please note that nominal values are also subject to tolerances. For more detailed information, see: ▶ *Note on nominal values [p.33]*

## 3.10.32 Max-30-F3, Max-30-F3-CTM, Max-30-F3-VAM

Mechanical properties	min.	typ.	max.	unit
Motor torque*		30		Nm
Motor runtime for 90° (can be configured with rotary switch)*		40 60 90 120 150		s
Spring torque*		24		Nm
Spring return period for 90° (The spring return time can vary at low temperatures. For further information, please contact our sales staff.)*		~3		s
Load torque, value must not be below this	8			Nm
Minimum angle of rotation*		-5		°
Maximum angle of rotation*		90		°
Weight* <ul style="list-style-type: none"> <li>• Max-30-F3</li> <li>• Max-30-F3-CTM</li> <li>• Max-30-F3-VAM</li> </ul>		9.5 9.5 17.4		kg kg kg

Dimensions	min.	typ.	max.	unit
Max-30-F3				
L	-1	288	+1	mm
W	-1	149	+1	mm
H	-1	116	+1	mm
Max-30-F3-CTM				
L	-1	288	+1	mm
W	-1	149	+1	mm
H	-1	116	+1	mm
Max-30-F3-VAM				
L	-1	289	+1	mm
W	-1	150	+1	mm
H	-1	116	+1	mm
Hollow shaft double square	16 x 16			mm
Allen key provided for manual adjustment in accordance with these instructions*		4		mm

Electrical characteristics	min.	typ.	max.	unit
Minimum nominal voltage (at room temperature)	-10 %	24	+10 %	VAC/DC
Maximum nominal voltage (at room temperature)	-10 %	240	+10 %	VAC/DC
Minimum mains frequency	-20 %	50	+20 %	Hz
Maximum mains frequency	-20 %	60	+20 %	Hz
Nominal current (at room temperature)	► <i>Nominal current [p.31]</i>			
Power consumption standby*		5		W
Power consumption heating mode*		16		W
Power consumption in operation	► <i>Nominal current [p.31]</i>			
Switch-on peak				
<ul style="list-style-type: none"> <li>at 24 VDC (for approx. 2 seconds)*</li> <li>at 240 VDC (for approx. 2 seconds)*</li> </ul>		2		A
		2		A
Maximum duty cycle for motor run time*				
40 s, 60 s, 90 s, 120 s, 150 s		100		%

## Electrical connection options

► <i>2-wire with spring return constant spring return period [p.22]</i>	Cable type 3+PE, cable diameter 6.0 mm
► <i>1-wire with spring return constant spring return period [p.23]</i>	Cable type 3+PE, cable diameter 6.0 mm

Ambient conditions	min.	typ.	max.	unit
Humidity (non-condensing)			90	% rH
Degree of protection to EN 60529	IP67			
Operation				
<ul style="list-style-type: none"> <li>Ambient temperature (T6)</li> <li>Ambient temperature (T5)</li> </ul>	-20		+40	°C
	-20		+50	°C
Storage				
<ul style="list-style-type: none"> <li>Ambient temperature</li> </ul>	-40		+70	°C

\*: Nominal value: please note that nominal values are also subject to tolerances. For more detailed information, see: ► *Note on nominal values [p.33]*

## 3.10.33 Max-30-SF, Max-30-SF-CTM, Max-30-SF-VAM

Mechanical properties	min.	typ.	max.	unit
Motor torque*		30		Nm
Motor runtime for 90° (can be configured with rotary switch)*		40 60 90 120 150		s
Spring torque*		30		Nm
Spring return period for 90°*		20		s
Minimum angle of rotation*		-5		°
Maximum angle of rotation*		90		°
Weight* <ul style="list-style-type: none"> <li>• Max-30-SF</li> <li>• Max-30-SF-CTM</li> <li>• Max-30-SF-VAM</li> </ul>		9.5 9.5 17.3		kg kg kg

Dimensions	min.	typ.	max.	unit
Max-30-SF				
L	-1	288	+1	mm
W	-1	149	+1	mm
H	-1	116	+1	mm
Max-30-SF-CTM				
L	-1	288	+1	mm
W	-1	149	+1	mm
H	-1	116	+1	mm
Max-30-SF-VAM				
L	-1	289	+1	mm
W	-1	150	+1	mm
H	-1	116	+1	mm
Hollow shaft double square	16 × 16			mm
Allen key provided for manual adjustment in accordance with these instructions*		4		mm

Electrical characteristics	min.	typ.	max.	unit
Minimum nominal voltage (at room temperature)	-10 %	24	+10 %	VAC/DC
Maximum nominal voltage (at room temperature)	-10 %	240	+10 %	VAC/DC

Electrical characteristics	min.	typ.	max.	unit
Minimum mains frequency	-20 %	50	+20 %	Hz
Maximum mains frequency	-20 %	60	+20 %	Hz
Nominal current (at room temperature)	▶ <i>Nominal current [p.31]</i>			
Power consumption standby*		5		W
Power consumption heating mode*		16		W
Power consumption in operation	▶ <i>Nominal current [p.31]</i>			
Switch-on peak				
<ul style="list-style-type: none"> <li>at 24 VDC (for approx. 2 seconds)*</li> <li>at 240 VDC (for approx. 2 seconds)*</li> </ul>		2		A
		2		A
Maximum duty cycle for motor run time* 40 s, 60 s, 90 s, 120 s, 150 s		100		%

Electrical connection options	
▶ <i>3-point with spring return constant spring return period [p.21]</i>	Cable type 4+PE, cable diameter 7.2 mm
▶ <i>1-wire with spring return constant spring return period [p.22]</i>	Cable type 4+PE, cable diameter 7.2 mm
▶ <i>Integrated limit switch [p.23]</i>	Cable type 6, cable diameter 7.4 mm

Electrical characteristics limit switch	min.	typ.	max.	unit
Switch point CLOSED	-2	5	+2	°
Switch point OPENED	-2	85	+2	°
Signal operation				
<ul style="list-style-type: none"> <li><math>U_{max}</math> DC*</li> <li><math>I_{max}</math> DC*</li> <li><math>I_{min}</math> AC/DC*</li> </ul>		48		V
		1		A
		5		mA
Power operation				
<ul style="list-style-type: none"> <li><math>U_{max}</math> AC*</li> <li><math>U_{min}</math> AC/DC*</li> <li><math>I_{max}</math> AC*</li> </ul>		250		V
		5		V
		5		A
After one-off operation with $U > 24$ VAC/DC or $I > 100$ mA:				
<ul style="list-style-type: none"> <li><math>U_{min}</math> AC/DC*</li> <li><math>I_{min}</math> AC/DC*</li> </ul>		12		V
		100		mA

## 3 | Device description

<b>Environmental conditions</b>	<b>min.</b>	<b>typ.</b>	<b>max.</b>	<b>unit</b>
Humidity (not condensing)			90	% rH
Protection class as per DIN EN 60529	IP67			
Operation				
• Ambient temperature (T6)	-40		+40	°C
• Ambient temperature (T5)	-40		+50	°C
Storage				
• Ambient temperature	-40		+70	°C

\*: Nominal value: please note that nominal values are also subject to tolerances. For more detailed information, see: ▶ *Note on nominal values [p.33]*



## 3.10.34 Max-30-SF3, Max-30-SF3-CTM, Max-30-SF3-VAM

Mechanical properties	min.	typ.	max.	unit
Motor torque*		30		Nm
Motor runtime for 90° (can be configured with rotary switch)*		40 60 90 120 150		s
Spring torque*		24		Nm
Spring return period for 90° (The spring return time can vary at low temperatures. For further information, please contact our sales staff.)*		~3		s
Load torque, value must not be below this	8			Nm
Minimum angle of rotation*		-5		°
Maximum angle of rotation*		90		°
Weight* <ul style="list-style-type: none"> <li>• Max-30-SF3</li> <li>• Max-30-SF3-CTM</li> <li>• Max-30-SF3-VAM</li> </ul>		9.5 9.5 17.4		kg kg kg

Dimensions	min.	typ.	max.	unit
Max-30-SF3				
L	-1	288	+1	mm
W	-1	149	+1	mm
H	-1	116	+1	mm
Max-30-SF3-CTM				
L	-1	288	+1	mm
W	-1	149	+1	mm
H	-1	116	+1	mm
Max-30-SF3-VAM				
L	-1	289	+1	mm
W	-1	150	+1	mm
H	-1	116	+1	mm
Hollow shaft double square	16 x 16			mm
Allen key provided for manual adjustment in accordance with these instructions*		4		mm

## 3 | Device description

Electrical characteristics	min.	typ.	max.	unit
Minimum nominal voltage (at room temperature)	-10 %	24	+10 %	VAC/DC
Maximum nominal voltage (at room temperature)	-10 %	240	+10 %	VAC/DC
Minimum mains frequency	-20 %	50	+20 %	Hz
Maximum mains frequency	-20 %	60	+20 %	Hz
Nominal current (at room temperature)	▶ <i>Nominal current [p.31]</i>			
Power consumption standby*		5		W
Power consumption heating mode*		16		W
Power consumption in operation	▶ <i>Nominal current [p.31]</i>			
Switch-on peak				
<ul style="list-style-type: none"> <li>at 24 VDC (for approx. 2 seconds)*</li> <li>at 240 VDC (for approx. 2 seconds)*</li> </ul>		2		A
		2		A
Maximum duty cycle for motor run time*				
40 s, 60 s, 90 s, 120 s, 150 s	100			%

### Electrical connection options

▶ <i>2-wire with spring return constant spring return period [p.22]</i>	Cable type 3+PE, cable diameter 6.0 mm
▶ <i>1-wire with spring return constant spring return period [p.23]</i>	Cable type 3+PE, cable diameter 6.0 mm
▶ <i>Integrated limit switch [p.24]</i>	Cable type 6, cable diameter 7.4 mm

### Electrical characteristics limit switch

Electrical characteristics limit switch	min.	typ.	max.	unit
Switch point CLOSED	-2	5	+2	°
Switch point OPENED	-2	85	+2	°
Signal operation				
<ul style="list-style-type: none"> <li><math>U_{max}</math> DC*</li> <li><math>I_{max}</math> DC*</li> <li><math>I_{min}</math> AC/DC*</li> </ul>		48		V
		1		A
		5		mA
Power operation				
<ul style="list-style-type: none"> <li><math>U_{max}</math> AC*</li> <li><math>U_{min}</math> AC/DC*</li> <li><math>I_{max}</math> AC*</li> </ul>		250		V
		5		V
		5		A

Electrical characteristics limit switch	min.	typ.	max.	unit
After one-off operation with $U > 24$ VAC/DC or $I > 100$ mA:				
• $U_{\min}$ AC/DC *		12		V
• $I_{\min}$ AC/DC *		100		mA
Ambient conditions	min.	typ.	max.	unit
Humidity (non-condensing)			90	% rH
Degree of protection to EN 60529	IP67			
Operation				
• Ambient temperature (T6)	-20		+40	°C
• Ambient temperature (T5)	-20		+50	°C
Storage				
• Ambient temperature	-40		+70	°C

\*: Nominal value: please note that nominal values are also subject to tolerances. For more detailed information, see: ▶ *Note on nominal values [p.33]*

## 3.10.35 Max-30-YF, Max-30-YF-CTM, Max-30-YF-VAM

Mechanical properties	min.	typ.	max.	unit
Motor torque*		30		Nm
Motor runtime for 90° (can be configured with rotary switch)*		40 60 90 120 150		s
Spring torque*		30		Nm
Spring return period for 90°*		20		s
Minimum angle of rotation*		-5		°
Maximum angle of rotation*		90		°
Weight* <ul style="list-style-type: none"> <li>• Max-30-YF</li> <li>• Max-30-YF-CTM</li> <li>• Max-30-YF-VAM</li> </ul>		9.5 9.5 17.3		kg kg kg

Dimensions	min.	typ.	max.	unit
Max-30-YF				
L	-1	288	+1	mm
W	-1	149	+1	mm
H	-1	116	+1	mm
Max-30-YF-CTM				
L	-1	288	+1	mm
W	-1	149	+1	mm
H	-1	116	+1	mm
Max-30-YF-VAM				
L	-1	289	+1	mm
W	-1	150	+1	mm
H	-1	116	+1	mm
Hollow shaft double square	16 × 16			mm
Allen key provided for manual adjustment in accordance with these instructions*		4		mm

Electrical characteristics	min.	typ.	max.	unit
Minimum nominal voltage (at room temperature)	-10 %	24	+10 %	VAC/DC
Maximum nominal voltage (at room temperature)	-10 %	240	+10 %	VAC/DC

Electrical characteristics	min.	typ.	max.	unit
Minimum mains frequency	-20 %	50	+20 %	Hz
Maximum mains frequency	-20 %	60	+20 %	Hz
Nominal current (at room temperature)	▶ <i>Nominal current [p.31]</i>			
Power consumption standby*		5		W
Power consumption heating mode*		16		W
Power consumption in operation	▶ <i>Nominal current [p.31]</i>			
Switch-on peak				
<ul style="list-style-type: none"> <li>at 24 VDC (for approx. 2 seconds)*</li> <li>at 240 VDC (for approx. 2 seconds)*</li> </ul>		2		A
		2		A
Maximum duty cycle for motor run time*	100			%
40 s, 60 s, 90 s, 120 s, 150 s				

Electrical connection options	
▶ <i>3-point with spring return constant spring return period continuous [p.24]</i>	Cable type 5+PE, cable diameter 7.5 mm / cable type 6, cable diameter 7.4 mm
▶ <i>1-wire with spring return with constant spring return period continuous [p.25]</i>	Cable type 4+PE, cable diameter 7.2 mm / cable type 6, cable diameter 7.4 mm

Activation CONTROL	min.	typ.	max.	unit
Angle of rotation and position indicator		95		°
Precision electrical*		~100		Step
Activation Y	0		10	VDC
	4		20	mA
Performance data Y and U				
<ul style="list-style-type: none"> <li>Activation <math>Y_U</math> (for 10 k<math>\Omega</math> output impedance)</li> <li>Activation <math>Y_I</math> (for 100 <math>\Omega</math> load / output impedance)</li> <li>Feedback <math>U_U</math> (for 10 k<math>\Omega</math>...<math>\infty</math> <math>\Omega</math> input impedance)</li> <li>Feedback <math>U_I</math> (for 0...800 <math>\Omega</math> load / input impedance)</li> </ul>	0		10	VDC
	4		20	mA
	0		10	VDC
	4		20	mA
Inverting	Setting up wire bridges between terminals 3 and 4			

Environmental conditions	min.	typ.	max.	unit
Humidity (not condensing)			90	% rH

## 3 | Device description

<b>Environmental conditions</b>	<b>min.</b>	<b>typ.</b>	<b>max.</b>	<b>unit</b>
Protection class as per DIN EN 60529	IP67			
Operation				
• Ambient temperature (T6)	-40		+40	°C
• Ambient temperature (T5)	-40		+50	°C
Storage				
• Ambient temperature	-40		+70	°C

\*: Nominal value: please note that nominal values are also subject to tolerances. For more detailed information, see: ▶ *Note on nominal values [p.33]*

## 3.10.36 Max-50-BF, Max-50-BF-CTM

Mechanical properties	min.	typ.	max.	unit
Motor torque*		50		Nm
Motor runtime for 90° (can be configured with rotary switch)*		40 60 90 120 150		s
Spring torque*		50		Nm
Spring return period for 90°*		20		s
Minimum angle of rotation*		-5		°
Maximum angle of rotation*		90		°
Weight* <ul style="list-style-type: none"> <li>• Max-50-BF</li> <li>• Max-50-BF-CTM</li> </ul>		9.5 9.5		kg kg

Dimensions	min.	typ.	max.	unit
Max-50-BF				
L	-1	288	+1	mm
W	-1	149	+1	mm
H	-1	116	+1	mm
Max-50-BF-CTM				
L	-1	288	+1	mm
W	-1	149	+1	mm
H	-1	116	+1	mm
Hollow shaft double square	16 × 16			mm
Allen key provided for manual adjustment in accordance with these instructions*		4		mm

Electrical characteristics	min.	typ.	max.	unit
Minimum nominal voltage (at room temperature)	-10 %	24	+10 %	VAC/DC
Maximum nominal voltage (at room temperature)	-10 %	240	+10 %	VAC/DC
Minimum mains frequency	-20 %	50	+20 %	Hz
Maximum mains frequency	-20 %	60	+20 %	Hz
Nominal current (at room temperature)	► <i>Nominal current [p.31]</i>			
Power consumption standby*		5		W

## 3 | Device description

Electrical characteristics	min.	typ.	max.	unit
Power consumption heating mode*		16		W
Power consumption in operation	▶ <i>Nominal current [p.31]</i>			
Switch-on peak				
<ul style="list-style-type: none"> <li>at 24 VDC (for approx. 2 seconds)*</li> <li>at 240 VDC (for approx. 2 seconds)*</li> </ul>		2		A
		2		A
Maximum duty cycle for motor run time*				
40 s, 60 s, 90 s, 120 s, 150 s		100		%

Electrical connection options	
▶ <i>1-wire with spring return with constant spring return period BF [p.29]</i>	Cable type 10+PE, cable diameter 9.4 mm
▶ <i>3-point with spring return with constant spring return period BF [p.30]</i>	Cable type 10+PE, cable diameter 9.4 mm

Electrical characteristics limit switch	min.	typ.	max.	unit
Switch point CLOSED	-2	5	+2	°
Switch point OPENED	-2	85	+2	°
Signal operation				
<ul style="list-style-type: none"> <li><math>U_{max}</math> DC*</li> <li><math>I_{max}</math> DC*</li> <li><math>I_{min}</math> AC/DC*</li> </ul>		48		V
		1		A
		5		mA
Power operation				
<ul style="list-style-type: none"> <li><math>U_{max}</math> AC*</li> <li><math>U_{min}</math> AC/DC*</li> <li><math>I_{max}</math> AC*</li> </ul>		250		V
		5		V
		5		A
After one-off operation with $U > 24$ VAC/DC or $I > 100$ mA:				
<ul style="list-style-type: none"> <li><math>U_{min}</math> AC/DC*</li> <li><math>I_{min}</math> AC/DC*</li> </ul>		12		V
		100		mA

Environmental conditions	min.	typ.	max.	unit
Humidity (not condensing)			90	% rH
Protection class as per DIN EN 60529	IP67			
Operation				



Environmental conditions	min.	typ.	max.	unit
<ul style="list-style-type: none"><li>Ambient temperature (T6)</li></ul>	-40		+40	°C
<ul style="list-style-type: none"><li>Ambient temperature (T5)</li></ul>	-40		+50	°C
Storage				
<ul style="list-style-type: none"><li>Ambient temperature</li></ul>	-40		+70	°C

\*: Nominal value: please note that nominal values are also subject to tolerances. For more detailed information, see: ▶ *Note on nominal values [p.33]*

## 3.10.37 Max-50-BF3, Max-50-BF3-CTM

Mechanical properties	min.	typ.	max.	unit
Motor torque*		50		Nm
Motor runtime for 90° (can be configured with rotary switch)*		40 60 90 120 150		s
Spring torque*		40		Nm
Spring return period for 90° (The spring return time can vary at low temperatures. For further information, please contact our sales staff.)*		~3		s
Load torque, value must not be below this	15			Nm
Minimum angle of rotation*		-5		°
Maximum angle of rotation*		90		°
Weight* <ul style="list-style-type: none"> <li>• Max-50-BF3</li> <li>• Max-50-BF3-CTM</li> </ul>		9.5 9.5		kg kg

Dimensions	min.	typ.	max.	unit
Max-50-BF3				
L	-1	288	+1	mm
W	-1	149	+1	mm
H	-1	116	+1	mm
Max-50-BF3-CTM				
L	-1	288	+1	mm
W	-1	149	+1	mm
H	-1	116	+1	mm
Hollow shaft double square	16 × 16			mm
Allen key provided for manual adjustment in accordance with these instructions*		4		mm

Electrical characteristics	min.	typ.	max.	unit
Minimum nominal voltage (at room temperature)	-10 %	24	+10 %	VAC/DC
Maximum nominal voltage (at room temperature)	-10 %	240	+10 %	VAC/DC
Minimum mains frequency	-20 %	50	+20 %	Hz
Maximum mains frequency	-20 %	60	+20 %	Hz

Electrical characteristics	min.	typ.	max.	unit
Nominal current (at room temperature)	▶ <i>Nominal current [p.31]</i>			
Power consumption standby*		5		W
Power consumption heating mode*		16		W
Power consumption in operation	▶ <i>Nominal current [p.31]</i>			
Switch-on peak				
<ul style="list-style-type: none"> <li>at 24 VDC (for approx. 2 seconds)*</li> <li>at 240 VDC (for approx. 2 seconds)*</li> </ul>		2		A
		2		A
Maximum duty cycle for motor run time*				
40 s, 60 s, 90 s, 120 s, 150 s	100			%

Electrical connection options	
▶ <i>2-wire with spring return constant spring return period [p.22]</i>	Cable type 3+PE, cable diameter 6.0 mm
▶ <i>1-wire with spring return constant spring return period [p.23]</i>	Cable type 3+PE, cable diameter 6.0 mm
▶ <i>1-wire with spring return constant spring return period BF1/BF3 [p.30]</i>	Cable type 9+PE, cable diameter 8.8 mm

Electrical characteristics limit switch	min.	typ.	max.	unit
Switch point CLOSED	-2	5	+2	°
Switch point OPENED	-2	85	+2	°
Signal operation				
<ul style="list-style-type: none"> <li><math>U_{max}</math> DC *</li> <li><math>I_{max}</math> DC *</li> <li><math>I_{min}</math> AC/DC *</li> </ul>		48		V
		1		A
		5		mA
Power operation				
<ul style="list-style-type: none"> <li><math>U_{max}</math> AC *</li> <li><math>U_{min}</math> AC/DC *</li> <li><math>I_{max}</math> AC *</li> </ul>		250		V
		5		V
		5		A
After one-off operation with $U > 24$ VAC/DC or $I > 100$ mA:				
<ul style="list-style-type: none"> <li><math>U_{min}</math> AC/DC *</li> <li><math>I_{min}</math> AC/DC *</li> </ul>		12		V
		100		mA

## 3 | Device description

Ambient conditions	min.	typ.	max.	unit
Humidity (non-condensing)			90	% rH
Degree of protection to EN 60529	IP67			
Operation				
• Ambient temperature (T6)	-20		+40	°C
• Ambient temperature (T5)	-20		+50	°C
Storage				
• Ambient temperature	-40		+70	°C

\*: Nominal value: please note that nominal values are also subject to tolerances. For more detailed information, see: ▶ *Note on nominal values [p.33]*

## 3.10.38 Max-50-F, Max-50-F-CTM

Mechanical properties	min.	typ.	max.	unit
Motor torque*		50		Nm
Motor runtime for 90° (can be configured with rotary switch)*		40 60 90 120 150		s
Spring torque*		50		Nm
Spring return period for 90°*		20		s
Minimum angle of rotation*		-5		°
Maximum angle of rotation*		90		°
Weight*				
<ul style="list-style-type: none"> <li>• Max-50-F</li> </ul>		9.5		kg
<ul style="list-style-type: none"> <li>• Max-50-F-CTM</li> </ul>		9.5		kg

Dimensions	min.	typ.	max.	unit
Max-50-F				
L	-1	288	+1	mm
W	-1	149	+1	mm
H	-1	116	+1	mm
Max-50-F-CTM				
L	-1	288	+1	mm
W	-1	149	+1	mm
H	-1	116	+1	mm
Hollow shaft double square	16 × 16			mm
Allen key provided for manual adjustment in accordance with these instructions*		4		mm

Electrical characteristics	min.	typ.	max.	unit
Minimum nominal voltage (at room temperature)	-10 %	24	+10 %	VAC/DC
Maximum nominal voltage (at room temperature)	-10 %	240	+10 %	VAC/DC
Minimum mains frequency	-20 %	50	+20 %	Hz
Maximum mains frequency	-20 %	60	+20 %	Hz
Nominal current (at room temperature)	▶ <i>Nominal current [p.31]</i>			
Power consumption standby*		5		W

## 3 | Device description

Electrical characteristics	min.	typ.	max.	unit
Power consumption heating mode*		16		W
Power consumption in operation	▶ <i>Nominal current [p.31]</i>			
Switch-on peak				
<ul style="list-style-type: none"> <li>at 24 VDC (for approx. 2 seconds)*</li> <li>at 240 VDC (for approx. 2 seconds)*</li> </ul>		2		A
		2		A
Maximum duty cycle for motor run time*				
40 s, 60 s, 90 s, 120 s, 150 s		100		%

Electrical connection options	
▶ <i>3-point with spring return constant spring return period [p.21]</i>	Cable type 4+PE, cable diameter 7.2 mm
▶ <i>1-wire with spring return constant spring return period [p.22]</i>	Cable type 4+PE, cable diameter 7.2 mm

Environmental conditions	min.	typ.	max.	unit
Humidity (not condensing)			90	% rH
Protection class as per DIN EN 60529	IP67			
Operation				
<ul style="list-style-type: none"> <li>Ambient temperature (T6)</li> <li>Ambient temperature (T5)</li> </ul>	-40		+40	°C
	-40		+50	°C
Storage				
<ul style="list-style-type: none"> <li>Ambient temperature</li> </ul>	-40		+70	°C

\*: Nominal value: please note that nominal values are also subject to tolerances. For more detailed information, see: ▶ *Note on nominal values [p.33]*

## 3.10.39 Max-50-F3, Max-50-F3-CTM

Mechanical properties	min.	typ.	max.	unit
Motor torque*		50		Nm
Motor runtime for 90° (can be configured with rotary switch)*		40 60 90 120 150		s
Spring torque*		40		Nm
Spring return period for 90° (The spring return time can vary at low temperatures. For further information, please contact our sales staff.)*		~3		s
Load torque, value must not be below this	15			Nm
Minimum angle of rotation*		-5		°
Maximum angle of rotation*		90		°
Weight* <ul style="list-style-type: none"> <li>• Max-50-F3</li> <li>• Max-50-F3-CTM</li> </ul>		9.5 9.5		kg kg

Dimensions	min.	typ.	max.	unit
Max-50-F3				
L	-1	288	+1	mm
W	-1	149	+1	mm
H	-1	116	+1	mm
Max-50-F3-CTM				
L	-1	288	+1	mm
W	-1	149	+1	mm
H	-1	116	+1	mm
Hollow shaft double square	16 × 16			mm
Allen key provided for manual adjustment in accordance with these instructions*		4		mm

Electrical characteristics	min.	typ.	max.	unit
Minimum nominal voltage (at room temperature)	-10 %	24	+10 %	VAC/DC
Maximum nominal voltage (at room temperature)	-10 %	240	+10 %	VAC/DC
Minimum mains frequency	-20 %	50	+20 %	Hz
Maximum mains frequency	-20 %	60	+20 %	Hz

## 3 | Device description

Electrical characteristics	min.	typ.	max.	unit
Nominal current (at room temperature)	▶ <i>Nominal current [p.31]</i>			
Power consumption standby*		5		W
Power consumption heating mode*		16		W
Power consumption in operation	▶ <i>Nominal current [p.31]</i>			
Switch-on peak				
<ul style="list-style-type: none"> <li>at 24 VDC (for approx. 2 seconds)*</li> </ul>		2		A
<ul style="list-style-type: none"> <li>at 240 VDC (for approx. 2 seconds)*</li> </ul>		2		A
Maximum duty cycle for motor run time*				
40 s, 60 s, 90 s, 120 s, 150 s	100			%

Electrical connection options	
▶ <i>2-wire with spring return constant spring return period [p.22]</i>	Cable type 3+PE, cable diameter 6.0 mm
▶ <i>1-wire with spring return constant spring return period [p.23]</i>	Cable type 3+PE, cable diameter 6.0 mm

Ambient conditions	min.	typ.	max.	unit
Humidity (non-condensing)			90	% rH
Degree of protection to EN 60529	IP67			
Operation				
<ul style="list-style-type: none"> <li>Ambient temperature (T6)</li> </ul>	-20		+40	°C
<ul style="list-style-type: none"> <li>Ambient temperature (T5)</li> </ul>	-20		+50	°C
Storage				
<ul style="list-style-type: none"> <li>Ambient temperature</li> </ul>	-40		+70	°C

\*: Nominal value: please note that nominal values are also subject to tolerances. For more detailed information, see: ▶ *Note on nominal values [p.33]*



## 3.10.40 Max-50-SF, Max-50-SF-CTM, Max-50-SF-VAM

Mechanical properties	min.	typ.	max.	unit
Motor torque*		50		Nm
Motor runtime for 90° (can be configured with rotary switch)*		40 60 90 120 150		s
Spring torque*		50		Nm
Spring return period for 90°*		20		s
Minimum angle of rotation*		-5		°
Maximum angle of rotation*		90		°
Weight*				
<ul style="list-style-type: none"> <li>• Max-50-SF</li> <li>• Max-50-SF-CTM</li> <li>• Max-50-SF-VAM</li> </ul>		9.5 9.5 17.3		kg kg kg

Dimensions	min.	typ.	max.	unit
Max-50-SF				
L	-1	288	+1	mm
W	-1	149	+1	mm
H	-1	116	+1	mm
Max-50-SF-CTM				
L	-1	288	+1	mm
W	-1	149	+1	mm
H	-1	116	+1	mm
Max-50-SF-VAM				
L	-1	289	+1	mm
W	-1	150	+1	mm
H	-1	116	+1	mm
Hollow shaft double square	16 × 16			mm
Allen key provided for manual adjustment in accordance with these instructions*		4		mm

Electrical characteristics	min.	typ.	max.	unit
Minimum nominal voltage (at room temperature)	-10 %	24	+10 %	VAC/DC
Maximum nominal voltage (at room temperature)	-10 %	240	+10 %	VAC/DC

## 3 | Device description

Electrical characteristics	min.	typ.	max.	unit
Minimum mains frequency	-20 %	50	+20 %	Hz
Maximum mains frequency	-20 %	60	+20 %	Hz
Nominal current (at room temperature)	▶ <i>Nominal current [p.31]</i>			
Power consumption standby*		5		W
Power consumption heating mode*		16		W
Power consumption in operation	▶ <i>Nominal current [p.31]</i>			
Switch-on peak				
<ul style="list-style-type: none"> <li>at 24 VDC (for approx. 2 seconds)*</li> <li>at 240 VDC (for approx. 2 seconds)*</li> </ul>		2		A
		2		A
Maximum duty cycle for motor run time* 40 s, 60 s, 90 s, 120 s, 150 s		100		%

Electrical connection options	
▶ <i>3-point with spring return constant spring return period [p.21]</i>	Cable type 4+PE, cable diameter 7.2 mm
▶ <i>1-wire with spring return constant spring return period [p.22]</i>	Cable type 4+PE, cable diameter 7.2 mm
▶ <i>Integrated limit switch [p.23]</i>	Cable type 6, cable diameter 7.4 mm

Electrical characteristics limit switch	min.	typ.	max.	unit
Switch point CLOSED	-2	5	+2	°
Switch point OPENED	-2	85	+2	°
Signal operation				
<ul style="list-style-type: none"> <li><math>U_{max}</math> DC*</li> <li><math>I_{max}</math> DC*</li> <li><math>I_{min}</math> AC/DC*</li> </ul>		48		V
		1		A
		5		mA
Power operation				
<ul style="list-style-type: none"> <li><math>U_{max}</math> AC*</li> <li><math>U_{min}</math> AC/DC*</li> <li><math>I_{max}</math> AC*</li> </ul>		250		V
		5		V
		5		A
After one-off operation with $U > 24$ VAC/DC or $I > 100$ mA:				
<ul style="list-style-type: none"> <li><math>U_{min}</math> AC/DC*</li> <li><math>I_{min}</math> AC/DC*</li> </ul>		12		V
		100		mA

<b>Environmental conditions</b>	<b>min.</b>	<b>typ.</b>	<b>max.</b>	<b>unit</b>
Humidity (not condensing)			90	% rH
Protection class as per DIN EN 60529	IP67			
Operation				
• Ambient temperature (T6)	-40		+40	°C
• Ambient temperature (T5)	-40		+50	°C
Storage				
• Ambient temperature	-40		+70	°C

\*: Nominal value: please note that nominal values are also subject to tolerances. For more detailed information, see: ▶ *Note on nominal values [p.33]*

## 3.10.41 Max-50-SF3, Max-50-SF3-CTM, Max-50-SF3-VAM

Mechanical properties	min.	typ.	max.	unit
Motor torque*		50		Nm
Motor runtime for 90° (can be configured with rotary switch)*		40 60 90 120 150		s
Spring torque*		40		Nm
Spring return period for 90° (The spring return time can vary at low temperatures. For further information, please contact our sales staff.)*		~3		s
Load torque, value must not be below this	15			Nm
Minimum angle of rotation*		-5		°
Maximum angle of rotation*		90		°
Weight* <ul style="list-style-type: none"> <li>• Max-50-SF3</li> <li>• Max-50-SF3-CTM</li> <li>• Max-50-SF3-VAM</li> </ul>		9.5 9.5 17.4		kg kg kg

Dimensions	min.	typ.	max.	unit
Max-50-SF3				
L	-1	288	+1	mm
W	-1	149	+1	mm
H	-1	116	+1	mm
Max-50-SF3-CTM				
L	-1	288	+1	mm
W	-1	149	+1	mm
H	-1	116	+1	mm
Max-50-SF3-VAM				
L	-1	289	+1	mm
W	-1	150	+1	mm
H	-1	116	+1	mm
Hollow shaft double square	16 x 16			mm
Allen key provided for manual adjustment in accordance with these instructions*		4		mm

Electrical characteristics	min.	typ.	max.	unit
Minimum nominal voltage (at room temperature)	-10 %	24	+10 %	VAC/DC
Maximum nominal voltage (at room temperature)	-10 %	240	+10 %	VAC/DC
Minimum mains frequency	-20 %	50	+20 %	Hz
Maximum mains frequency	-20 %	60	+20 %	Hz
Nominal current (at room temperature)	▶ <i>Nominal current [p.31]</i>			
Power consumption standby*		5		W
Power consumption heating mode*		16		W
Power consumption in operation	▶ <i>Nominal current [p.31]</i>			
Switch-on peak				
<ul style="list-style-type: none"> <li>at 24 VDC (for approx. 2 seconds)*</li> <li>at 240 VDC (for approx. 2 seconds)*</li> </ul>		2		A
		2		A
Maximum duty cycle for motor run time*				
40 s, 60 s, 90 s, 120 s, 150 s		100		%

## Electrical connection options

▶ <i>2-wire with spring return constant spring return period [p.22]</i>	Cable type 3+PE, cable diameter 6.0 mm
▶ <i>1-wire with spring return constant spring return period [p.23]</i>	Cable type 3+PE, cable diameter 6.0 mm
▶ <i>Integrated limit switch [p.24]</i>	Cable type 6, cable diameter 7.4 mm

Electrical characteristics limit switch	min.	typ.	max.	unit
Switch point CLOSED	-2	5	+2	°
Switch point OPENED	-2	85	+2	°
Signal operation				
<ul style="list-style-type: none"> <li><math>U_{\max}</math> DC *</li> <li><math>I_{\max}</math> DC *</li> <li><math>I_{\min}</math> AC/DC *</li> </ul>		48		V
		1		A
		5		mA
Power operation				
<ul style="list-style-type: none"> <li><math>U_{\max}</math> AC *</li> <li><math>U_{\min}</math> AC/DC *</li> <li><math>I_{\max}</math> AC *</li> </ul>		250		V
		5		V
		5		A

## 3 | Device description

Electrical characteristics limit switch	min.	typ.	max.	unit
After one-off operation with $U > 24$ VAC/DC or $I > 100$ mA:				
• $U_{\min}$ AC/DC*		12		V
• $I_{\min}$ AC/DC*		100		mA
Ambient conditions	min.	typ.	max.	unit
Humidity (non-condensing)			90	% rH
Degree of protection to EN 60529	IP67			
Operation				
• Ambient temperature (T6)	-20		+40	°C
• Ambient temperature (T5)	-20		+50	°C
Storage				
• Ambient temperature	-40		+70	°C

\*: Nominal value: please note that nominal values are also subject to tolerances. For more detailed information, see: ▶ *Note on nominal values [p.33]*

## 3.10.42 Max-50-YF, Max-50-YF-CTM

Mechanical properties	min.	typ.	max.	unit
Motor torque*		50		Nm
Motor runtime for 90° (can be configured with rotary switch)*		40 60 90 120 150		s
Spring torque*		50		Nm
Spring return period for 90°*		20		s
Minimum angle of rotation*		-5		°
Maximum angle of rotation*		90		°
Weight* <ul style="list-style-type: none"> <li>• Max-50-YF</li> <li>• Max-50-YF-CTM</li> </ul>		9.5 9.5		kg kg

Dimensions	min.	typ.	max.	unit
Max-50-YF				
L	-1	288	+1	mm
W	-1	149	+1	mm
H	-1	116	+1	mm
Max-50-YF-CTM				
L	-1	288	+1	mm
W	-1	149	+1	mm
H	-1	116	+1	mm
Hollow shaft double square	16 × 16			mm
Allen key provided for manual adjustment in accordance with these instructions*		4		mm

Electrical characteristics	min.	typ.	max.	unit
Minimum nominal voltage (at room temperature)	-10 %	24	+10 %	VAC/DC
Maximum nominal voltage (at room temperature)	-10 %	240	+10 %	VAC/DC
Minimum mains frequency	-20 %	50	+20 %	Hz
Maximum mains frequency	-20 %	60	+20 %	Hz
Nominal current (at room temperature)	▶ <i>Nominal current [p.31]</i>			
Power consumption standby*		5		W

## 3 | Device description

Electrical characteristics	min.	typ.	max.	unit
Power consumption heating mode*		16		W
Power consumption in operation	▶ <i>Nominal current [p.31]</i>			
Switch-on peak				
<ul style="list-style-type: none"> <li>at 24 VDC (for approx. 2 seconds)*</li> <li>at 240 VDC (for approx. 2 seconds)*</li> </ul>		2		A
		2		A
Maximum duty cycle for motor run time*				
40 s, 60 s, 90 s, 120 s, 150 s		100		%

Electrical connection options	
▶ <i>3-point with spring return constant spring return period continuous [p.24]</i>	Cable type 5+PE, cable diameter 7.5 mm / cable type 6, cable diameter 7.4 mm
▶ <i>1-wire with spring return with constant spring return period continuous [p.25]</i>	Cable type 4+PE, cable diameter 7.2 mm / cable type 6, cable diameter 7.4 mm

Activation CONTROL	min.	typ.	max.	unit
Angle of rotation and position indicator		95		°
Precision electrical*		~100		Step
Activation Y	0		10	VDC
	4		20	mA
Performance data Y and U				
<ul style="list-style-type: none"> <li>Activation <math>Y_U</math> (for 10 k<math>\Omega</math> output impedance)</li> <li>Activation <math>Y_1</math> (for 100 <math>\Omega</math> load / output impedance)</li> <li>Feedback <math>U_U</math> (for 10 k<math>\Omega</math>...<math>\infty</math> <math>\Omega</math> input impedance)</li> <li>Feedback <math>U_1</math> (for 0...800 <math>\Omega</math> load / input impedance)</li> </ul>	0		10	VDC
	4		20	mA
	0		10	VDC
	4		20	mA
Inverting	Setting up wire bridges between terminals 3 and 4			

Environmental conditions	min.	typ.	max.	unit
Humidity (not condensing)			90	% rH
Protection class as per DIN EN 60529	IP67			
Operation				
<ul style="list-style-type: none"> <li>Ambient temperature (T6)</li> <li>Ambient temperature (T5)</li> </ul>	-40		+40	°C
	-40		+50	°C



Environmental conditions	min.	typ.	max.	unit
Storage				
<ul style="list-style-type: none"><li>Ambient temperature</li></ul>	-40		+70	°C

\*: Nominal value: please note that nominal values are also subject to tolerances. For more detailed information, see: ▶ *Note on nominal values [p.33]*

## 3 | Device description

### 3.10.43 Max-60-BF

Mechanical properties	min.	typ.	max.	unit
Motor torque*		60		Nm
Motor runtime for 90° (can be configured with rotary switch)*		40 60 90 120		s
Spring torque*		60		Nm
Spring return period for 90°*		20		s
Minimum angle of rotation*		-5		°
Maximum angle of rotation*		90		°
Weight* <ul style="list-style-type: none"> <li>Max-60-BF</li> </ul>		9.5		kg

Dimensions	min.	typ.	max.	unit
Max-60-BF				
L	-1	288	+1	mm
W	-1	149	+1	mm
H	-1	116	+1	mm
Hollow shaft double square	16 × 16			mm
Allen key provided for manual adjustment in accordance with these instructions*		4		mm

Electrical characteristics	min.	typ.	max.	unit
Minimum nominal voltage (at room temperature)	-10 %	24	+10 %	VAC/DC
Maximum nominal voltage (at room temperature)	-10 %	240	+10 %	VAC/DC
Minimum mains frequency	-20 %	50	+20 %	Hz
Maximum mains frequency	-20 %	60	+20 %	Hz
Nominal current (at room temperature)	▶ <i>Nominal current [p.31]</i>			
Power consumption standby*		5		W
Power consumption heating mode*		16		W
Power consumption in operation	▶ <i>Nominal current [p.31]</i>			
Switch-on peak <ul style="list-style-type: none"> <li>at 24 VDC (for approx. 2 seconds)*</li> <li>at 240 VDC (for approx. 2 seconds)*</li> </ul>		2		A

Electrical characteristics	min.	typ.	max.	unit
Maximum duty cycle for motor run time* 40 s, 60 s, 90 s, 120 s		100		%

Electrical connection options				
▶ 1-wire with spring return with constant spring return period BF [p.29]	Cable type 10+PE, cable diameter 9.4 mm			
▶ 3-point with spring return with constant spring return period BF [p.30]	Cable type 10+PE, cable diameter 9.4 mm			

Electrical characteristics limit switch	min.	typ.	max.	unit
Switch point CLOSED	-2	5	+2	°
Switch point OPENED	-2	85	+2	°
Signal operation				
• $U_{max}$ DC *		48		V
• $I_{max}$ DC *		1		A
• $I_{min}$ AC/DC *		5		mA
Power operation				
• $U_{max}$ AC *		250		V
• $U_{min}$ AC/DC *		5		V
• $I_{max}$ AC *		5		A
After one-off operation with $U > 24$ VAC/DC or $I > 100$ mA:				
• $U_{min}$ AC/DC *		12		V
• $I_{min}$ AC/DC *		100		mA

Environmental conditions	min.	typ.	max.	unit
Humidity (not condensing)			90	% rH
Protection class as per DIN EN 60529	IP67			
Operation				
• Ambient temperature (T6)	-40		+40	°C
• Ambient temperature (T5)	-40		+50	°C
Storage				
• Ambient temperature	-40		+70	°C

\*: Nominal value: please note that nominal values are also subject to tolerances. For more detailed information, see: ▶ *Note on nominal values [p.33]*

## 3 | Device description

### 3.10.44 Max-60-F, Max-60-F-CTM

Mechanical properties	min.	typ.	max.	unit
Motor torque*		60		Nm
Motor runtime for 90° (can be configured with rotary switch)*		40 60 90 120		s
Spring torque*		60		Nm
Spring return period for 90°*		20		s
Minimum angle of rotation*		-5		°
Maximum angle of rotation*		90		°
Weight*				
• Max-60-F		9.5		kg
• Max-60-F-CTM		9.5		kg

Dimensions	min.	typ.	max.	unit
Max-60-F				
L	-1	288	+1	mm
W	-1	149	+1	mm
H	-1	116	+1	mm
Max-60-F-CTM				
L	-1	288	+1	mm
W	-1	149	+1	mm
H	-1	116	+1	mm
Hollow shaft double square	16 × 16			mm
Allen key provided for manual adjustment in accordance with these instructions*		4		mm

Electrical characteristics	min.	typ.	max.	unit
Minimum nominal voltage (at room temperature)	-10 %	24	+10 %	VAC/DC
Maximum nominal voltage (at room temperature)	-10 %	240	+10 %	VAC/DC
Minimum mains frequency	-20 %	50	+20 %	Hz
Maximum mains frequency	-20 %	60	+20 %	Hz
Nominal current (at room temperature)	▶ <i>Nominal current [p.31]</i>			
Power consumption standby*		5		W
Power consumption heating mode*		16		W

Electrical characteristics	min.	typ.	max.	unit
Power consumption in operation	▶ <i>Nominal current [p.31]</i>			
Switch-on peak				
<ul style="list-style-type: none"> <li>at 24 VDC (for approx. 2 seconds)*</li> <li>at 240 VDC (for approx. 2 seconds)*</li> </ul>		2		A
		2		A
Maximum duty cycle for motor run time*				
40 s, 60 s, 90 s, 120 s		100		%

Electrical connection options	
▶ <i>3-point with spring return constant spring return period [p.21]</i>	Cable type 4+PE, cable diameter 7.2 mm
▶ <i>1-wire with spring return constant spring return period [p.22]</i>	Cable type 4+PE, cable diameter 7.2 mm

Environmental conditions	min.	typ.	max.	unit
Humidity (not condensing)			90	% rH
Protection class as per DIN EN 60529	IP67			
Operation				
<ul style="list-style-type: none"> <li>Ambient temperature (T6)</li> <li>Ambient temperature (T5)</li> </ul>	-40		+40	°C
	-40		+50	°C
Storage				
<ul style="list-style-type: none"> <li>Ambient temperature</li> </ul>	-40		+70	°C

\*: Nominal value: please note that nominal values are also subject to tolerances. For more detailed information, see: ▶ *Note on nominal values [p.33]*

## 3.10.45 Max-60-SF, Max-60-SF-CTM

Mechanical properties	min.	typ.	max.	unit
Motor torque*		60		Nm
Motor runtime for 90° (can be configured with rotary switch)*		40 60 90 120		s
Spring torque*		60		Nm
Spring return period for 90°*		20		s
Minimum angle of rotation*		-5		°
Maximum angle of rotation*		90		°
Weight* <ul style="list-style-type: none"> <li>• Max-60-SF</li> <li>• Max-60-SF-CTM</li> </ul>		9.5 9.5		kg kg

Dimensions	min.	typ.	max.	unit
Max-60-SF				
L	-1	288	+1	mm
W	-1	149	+1	mm
H	-1	116	+1	mm
Max-60-SF-CTM				
L	-1	288	+1	mm
W	-1	149	+1	mm
H	-1	116	+1	mm
Hollow shaft double square	16 × 16			mm
Allen key provided for manual adjustment in accordance with these instructions*		4		mm

Electrical characteristics	min.	typ.	max.	unit
Minimum nominal voltage (at room temperature)	-10 %	24	+10 %	VAC/DC
Maximum nominal voltage (at room temperature)	-10 %	240	+10 %	VAC/DC
Minimum mains frequency	-20 %	50	+20 %	Hz
Maximum mains frequency	-20 %	60	+20 %	Hz
Nominal current (at room temperature)	▶ <i>Nominal current [p.31]</i>			
Power consumption standby*		5		W
Power consumption heating mode*		16		W

Electrical characteristics	min.	typ.	max.	unit
Power consumption in operation	▶ <i>Nominal current [p.31]</i>			
Switch-on peak				
<ul style="list-style-type: none"> <li>at 24 VDC (for approx. 2 seconds)*</li> <li>at 240 VDC (for approx. 2 seconds)*</li> </ul>		2		A
		2		A
Maximum duty cycle for motor run time*				
40 s, 60 s, 90 s, 120 s		100		%

Electrical connection options	
▶ <i>3-point with spring return constant spring return period [p.21]</i>	Cable type 4+PE, cable diameter 7.2 mm
▶ <i>1-wire with spring return constant spring return period [p.22]</i>	Cable type 4+PE, cable diameter 7.2 mm
▶ <i>Integrated limit switch [p.23]</i>	Cable type 6, cable diameter 7.4 mm

Electrical characteristics limit switch	min.	typ.	max.	unit
Switch point CLOSED	-2	5	+2	°
Switch point OPENED	-2	85	+2	°
Signal operation				
<ul style="list-style-type: none"> <li><math>U_{max}</math> DC*</li> <li><math>I_{max}</math> DC*</li> <li><math>I_{min}</math> AC/DC*</li> </ul>		48		V
		1		A
		5		mA
Power operation				
<ul style="list-style-type: none"> <li><math>U_{max}</math> AC*</li> <li><math>U_{min}</math> AC/DC*</li> <li><math>I_{max}</math> AC*</li> </ul>		250		V
		5		V
		5		A
After one-off operation with $U > 24$ VAC/DC or $I > 100$ mA:				
<ul style="list-style-type: none"> <li><math>U_{min}</math> AC/DC*</li> <li><math>I_{min}</math> AC/DC*</li> </ul>		12		V
		100		mA

Environmental conditions	min.	typ.	max.	unit
Humidity (not condensing)			90	% rH
Protection class as per DIN EN 60529	IP67			
Operation				

## 3 | Device description

<b>Environmental conditions</b>	<b>min.</b>	<b>typ.</b>	<b>max.</b>	<b>unit</b>
• Ambient temperature (T6)	-40		+40	°C
• Ambient temperature (T5)	-40		+50	°C
Storage				
• Ambient temperature	-40		+70	°C

\*: Nominal value: please note that nominal values are also subject to tolerances. For more detailed information, see: ▶ *Note on nominal values [p.33]*



## 3.10.46 Max-50.75, Max-50.75-CTM, Max-50.75-VAM

Mechanical properties	min.	typ.	max.	unit
Motor torque (can be configured with rotary switch)*		50/75		Nm
Motor runtime for 90° (can be configured with rotary switch)*		40 60 90 120 150		s
Minimum angle of rotation*		-5		°
Maximum angle of rotation*		90		°
Weight* <ul style="list-style-type: none"> <li>• Max-50.75</li> <li>• Max-50.75-CTM</li> <li>• Max-50.75-VAM</li> </ul>		8 8 15.9		kg kg kg

Dimensions	min.	typ.	max.	unit
Max-50.75				
L	-1	288	+1	mm
W	-1	149	+1	mm
H	-1	116	+1	mm
Max-50.75-CTM				
L	-1	288	+1	mm
W	-1	149	+1	mm
H	-1	116	+1	mm
Max-50.75-VAM				
L	-1	289	+1	mm
W	-1	150	+1	mm
H	-1	116	+1	mm
Hollow shaft double square	16 × 16			mm
Allen key provided for manual adjustment in accordance with these instructions*		4		mm

Electrical characteristics	min.	typ.	max.	unit
Minimum nominal voltage (at room temperature)	-10 %	24	+10 %	VAC/DC
Maximum nominal voltage (at room temperature)	-10 %	240	+10 %	VAC/DC
Minimum mains frequency	-20 %	50	+20 %	Hz
Maximum mains frequency	-20 %	60	+20 %	Hz

## 3 | Device description

Electrical characteristics	min.	typ.	max.	unit
Nominal current (at room temperature)	▶ <i>Nominal current [p.31]</i>			
Power consumption standby*		5		W
Power consumption heating mode*		16		W
Power consumption in operation	▶ <i>Nominal current [p.31]</i>			
Switch-on peak				
<ul style="list-style-type: none"> <li>at 24 VDC (for approx. 2 seconds)*</li> </ul>		2		A
<ul style="list-style-type: none"> <li>at 240 VDC (for approx. 2 seconds)*</li> </ul>		2		A
Maximum duty cycle for motor run time*				
40 s, 60 s, 90 s, 120 s, 150 s	100			%

Electrical connection options	
▶ <i>3-point no spring return [p.20]</i>	Cable type 4+PE, cable diameter 7.2 mm

Environmental conditions	min.	typ.	max.	unit
Humidity (not condensing)			90	% rH
Protection class as per DIN EN 60529	IP67			
Operation				
<ul style="list-style-type: none"> <li>Ambient temperature (T6)</li> </ul>	-40		+40	°C
<ul style="list-style-type: none"> <li>Ambient temperature (T5)</li> </ul>	-40		+50	°C
Storage				
<ul style="list-style-type: none"> <li>Ambient temperature</li> </ul>	-40		+70	°C

\*: Nominal value: please note that nominal values are also subject to tolerances. For more detailed information, see: ▶ *Note on nominal values [p.33]*

## 3.10.47 Max-50.75-S, Max-50.75-S-CTM

Mechanical properties	min.	typ.	max.	unit
Motor torque (can be configured with rotary switch)*		50/75		Nm
Motor runtime for 90° (can be configured with rotary switch)*		40 60 90 120 150		s
Minimum angle of rotation*		-5		°
Maximum angle of rotation*		90		°
Weight* <ul style="list-style-type: none"> <li>• Max-50.75-S</li> <li>• Max-50.75-S-CTM</li> </ul>		8		kg

Dimensions	min.	typ.	max.	unit
Max-50.75-S				
L	-1	288	+1	mm
W	-1	149	+1	mm
H	-1	116	+1	mm
Max-50.75-S-CTM				
L	-1	288	+1	mm
W	-1	149	+1	mm
H	-1	116	+1	mm
Hollow shaft double square	16 × 16			mm
Allen key provided for manual adjustment in accordance with these instructions*		4		mm

Electrical characteristics	min.	typ.	max.	unit
Minimum nominal voltage (at room temperature)	-10 %	24	+10 %	VAC/DC
Maximum nominal voltage (at room temperature)	-10 %	240	+10 %	VAC/DC
Minimum mains frequency	-20 %	50	+20 %	Hz
Maximum mains frequency	-20 %	60	+20 %	Hz
Nominal current (at room temperature)	▶ <i>Nominal current [p.31]</i>			
Power consumption standby*		5		W
Power consumption heating mode*		16		W
Power consumption in operation	▶ <i>Nominal current [p.31]</i>			

## 3 | Device description

Electrical characteristics	min.	typ.	max.	unit
Switch-on peak				
<ul style="list-style-type: none"> <li>at 24 VDC (for approx. 2 seconds)*</li> <li>at 240 VDC (for approx. 2 seconds)*</li> </ul>		2		A
		2		A
Maximum duty cycle for motor run time*				
40 s, 60 s, 90 s, 120 s, 150 s		100		%

Electrical connection options	
▶ 3-point no spring return [p.20]	Cable type 4+PE, cable diameter 7.2 mm
▶ Integrated limit switch [p.23]	Cable type 6, cable diameter 7.4 mm

Electrical characteristics limit switch	min.	typ.	max.	unit
Switch point CLOSED	-2	5	+2	°
Switch point OPENED	-2	85	+2	°
Signal operation				
<ul style="list-style-type: none"> <li><math>U_{max}</math> DC*</li> <li><math>I_{max}</math> DC*</li> <li><math>I_{min}</math> AC/DC*</li> </ul>		48		V
		1		A
		5		mA
Power operation				
<ul style="list-style-type: none"> <li><math>U_{max}</math> AC*</li> <li><math>U_{min}</math> AC/DC*</li> <li><math>I_{max}</math> AC*</li> </ul>		250		V
		5		V
		5		A
After one-off operation with $U > 24$ VAC/DC or $I > 100$ mA:				
<ul style="list-style-type: none"> <li><math>U_{min}</math> AC/DC*</li> <li><math>I_{min}</math> AC/DC*</li> </ul>		12		V
		100		mA

Environmental conditions	min.	typ.	max.	unit
Humidity (not condensing)			90	% rH
Protection class as per DIN EN 60529	IP67			
Operation				
<ul style="list-style-type: none"> <li>Ambient temperature (T6)</li> <li>Ambient temperature (T5)</li> </ul>	-40		+40	°C
	-40		+50	°C
Storage				

Environmental conditions	min.	typ.	max.	unit
<ul style="list-style-type: none"><li>Ambient temperature</li></ul>	-40		+70	°C

\*: Nominal value: please note that nominal values are also subject to tolerances. For more detailed information, see: ▶ *Note on nominal values [p.33]*

## 3.10.48 Max-50.75-Y, Max-50.75-Y-CTM

Mechanical properties	min.	typ.	max.	unit
Motor torque (can be configured with rotary switch)*		50/75		Nm
Motor runtime for 90° (can be configured with rotary switch)*		40 60 90 120 150		s
Minimum angle of rotation*		-5		°
Maximum angle of rotation*		90		°
Weight*				
<ul style="list-style-type: none"> <li>Max-50.75-Y</li> </ul>		8		kg
<ul style="list-style-type: none"> <li>Max-50.75-Y-CTM</li> </ul>		8		kg

Dimensions	min.	typ.	max.	unit
Max-50.75-Y				
L	-1	288	+1	mm
W	-1	149	+1	mm
H	-1	116	+1	mm
Max-50.75-Y-CTM				
L	-1	288	+1	mm
W	-1	149	+1	mm
H	-1	116	+1	mm
Hollow shaft double square	16 x 16			mm
Allen key provided for manual adjustment in accordance with these instructions*		4		mm

Electrical characteristics	min.	typ.	max.	unit
Minimum nominal voltage (at room temperature)	-10 %	24	+10 %	VAC/DC
Maximum nominal voltage (at room temperature)	-10 %	240	+10 %	VAC/DC
Minimum mains frequency	-20 %	50	+20 %	Hz
Maximum mains frequency	-20 %	60	+20 %	Hz
Nominal current (at room temperature)	▶ <i>Nominal current [p.31]</i>			
Power consumption standby*		5		W
Power consumption heating mode*		16		W
Power consumption in operation	▶ <i>Nominal current [p.31]</i>			

Electrical characteristics	min.	typ.	max.	unit
Switch-on peak				
<ul style="list-style-type: none"> <li>at 24 VDC (for approx. 2 seconds)*</li> <li>at 240 VDC (for approx. 2 seconds)*</li> </ul>		2		A
Maximum duty cycle for motor run time*				
40 s, 60 s, 90 s, 120 s, 150 s		100		%

Electrical connection options	
▶ 3-point with spring return constant spring return period continuous [p.24]	Cable type 5+PE, cable diameter 7.5 mm / cable type 6, cable diameter 7.4 mm
▶ 1-wire with spring return with constant spring return period continuous [p.25]	Cable type 4+PE, cable diameter 7.2 mm / cable type 6, cable diameter 7.4 mm

Activation CONTROL	min.	typ.	max.	unit
Angle of rotation and position indicator		95		°
Precision electrical*		~100		Step
Activation Y	0		10	VDC
	4		20	mA
Performance data Y and U				
<ul style="list-style-type: none"> <li>Activation <math>Y_U</math> (for 10 k<math>\Omega</math> output impedance)</li> <li>Activation <math>Y_I</math> (for 100 <math>\Omega</math> load / output impedance)</li> <li>Feedback <math>U_U</math> (for 10 k<math>\Omega</math>...<math>\infty</math> <math>\Omega</math> input impedance)</li> <li>Feedback <math>U_I</math> (for 0...800 <math>\Omega</math> load / input impedance)</li> </ul>	0		10	VDC
	4		20	mA
	0		10	VDC
	4		20	mA
Inverting	Setting up wire bridges between terminals 3 and 4			

Environmental conditions	min.	typ.	max.	unit
Humidity (not condensing)			90	% rH
Protection class as per DIN EN 60529	IP67			
Operation				
<ul style="list-style-type: none"> <li>Ambient temperature (T6)</li> <li>Ambient temperature (T5)</li> </ul>	-40		+40	°C
	-40		+50	°C
Storage				
<ul style="list-style-type: none"> <li>Ambient temperature</li> </ul>	-40		+70	°C

\*: Nominal value: please note that nominal values are also subject to tolerances. For more detailed information, see: ▶ *Note on nominal values [p.33]*



## 3.10.49 Max-100, Max-100-CTM

Mechanical properties	min.	typ.	max.	unit
Motor torque*		100		Nm
Motor runtime for 90° (can be configured with rotary switch)*		40 60 90 120 150		s
Minimum angle of rotation*		-5		°
Maximum angle of rotation*		90		°
Weight*				
• Max-100		8		kg
• Max-100-CTM		8		kg

Dimensions	min.	typ.	max.	unit
Max-100				
L	-1	288	+1	mm
W	-1	149	+1	mm
H	-1	116	+1	mm
Max-100-CTM				
L	-1	288	+1	mm
W	-1	149	+1	mm
H	-1	116	+1	mm
Hollow shaft double square	16 × 16			mm
Allen key provided for manual adjustment in accordance with these instructions*		4		mm

Electrical characteristics	min.	typ.	max.	unit
Minimum nominal voltage (at room temperature)	-10 %	24	+10 %	VAC/DC
Maximum nominal voltage (at room temperature)	-10 %	240	+10 %	VAC/DC
Minimum mains frequency	-20 %	50	+20 %	Hz
Maximum mains frequency	-20 %	60	+20 %	Hz
Nominal current (at room temperature)	▶ <i>Nominal current [p.31]</i>			
Power consumption standby*		5		W
Power consumption heating mode*		16		W
Power consumption in operation	▶ <i>Nominal current [p.31]</i>			

## 3 | Device description

Electrical characteristics	min.	typ.	max.	unit
Switch-on peak				
<ul style="list-style-type: none"> <li>at 24 VDC (for approx. 2 seconds)*</li> <li>at 240 VDC (for approx. 2 seconds)*</li> </ul>		2		A
		2		A
Maximum duty cycle for motor run time*				
40 s, 60 s, 90 s, 120 s, 150 s	100			%

**Electrical connection options**

▶ 3-point no spring return [p.20]	Cable type 4+PE, cable diameter 7.2 mm
-----------------------------------	--

Environmental conditions	min.	typ.	max.	unit
Humidity (not condensing)			90	% rH
Protection class as per DIN EN 60529	IP67			
Operation				
<ul style="list-style-type: none"> <li>Ambient temperature (T6)</li> <li>Ambient temperature (T5)</li> </ul>	-40		+40	°C
	-40		+50	°C
Storage				
<ul style="list-style-type: none"> <li>Ambient temperature</li> </ul>	-40		+70	°C

\*: Nominal value: please note that nominal values are also subject to tolerances. For more detailed information, see: ▶ *Note on nominal values [p.33]*

## 3.10.50 Max-100-S, Max-100-S-CTM

Mechanical properties	min.	typ.	max.	unit
Motor torque*		100		Nm
Motor runtime for 90° (can be configured with rotary switch)*		40 60 90 120 150		s
Minimum angle of rotation*		-5		°
Maximum angle of rotation*		90		°
Weight*				
• Max-100-S		8		kg
• Max-100-S-CTM		8		kg

Dimensions	min.	typ.	max.	unit
Max-100-S				
L	-1	288	+1	mm
W	-1	149	+1	mm
H	-1	116	+1	mm
Max-100-S-CTM				
L	-1	288	+1	mm
W	-1	149	+1	mm
H	-1	116	+1	mm
Hollow shaft double square	16 × 16			mm
Allen key provided for manual adjustment in accordance with these instructions*		4		mm

Electrical characteristics	min.	typ.	max.	unit
Minimum nominal voltage (at room temperature)	-10 %	24	+10 %	VAC/DC
Maximum nominal voltage (at room temperature)	-10 %	240	+10 %	VAC/DC
Minimum mains frequency	-20 %	50	+20 %	Hz
Maximum mains frequency	-20 %	60	+20 %	Hz
Nominal current (at room temperature)	▶ <i>Nominal current [p.31]</i>			
Power consumption standby*		5		W
Power consumption heating mode*		16		W
Power consumption in operation	▶ <i>Nominal current [p.31]</i>			

## 3 | Device description

Electrical characteristics	min.	typ.	max.	unit
Switch-on peak				
<ul style="list-style-type: none"> <li>at 24 VDC (for approx. 2 seconds)*</li> <li>at 240 VDC (for approx. 2 seconds)*</li> </ul>		2		A
		2		A
Maximum duty cycle for motor run time*				
40 s, 60 s, 90 s, 120 s, 150 s		100		%

Electrical connection options				
▶ 3-point no spring return [p.20]		Cable type 4+PE, cable diameter 7.2 mm		
▶ Integrated limit switch [p.23]		Cable type 6, cable diameter 7.4 mm		

Electrical characteristics limit switch	min.	typ.	max.	unit
Switch point CLOSED	-2	5	+2	°
Switch point OPENED	-2	85	+2	°
Signal operation				
<ul style="list-style-type: none"> <li><math>U_{max}</math> DC*</li> <li><math>I_{max}</math> DC*</li> <li><math>I_{min}</math> AC/DC*</li> </ul>		48		V
		1		A
		5		mA
Power operation				
<ul style="list-style-type: none"> <li><math>U_{max}</math> AC*</li> <li><math>U_{min}</math> AC/DC*</li> <li><math>I_{max}</math> AC*</li> </ul>		250		V
		5		V
		5		A
After one-off operation with $U > 24$ VAC/DC or $I > 100$ mA:				
<ul style="list-style-type: none"> <li><math>U_{min}</math> AC/DC*</li> <li><math>I_{min}</math> AC/DC*</li> </ul>		12		V
		100		mA

Environmental conditions	min.	typ.	max.	unit
Humidity (not condensing)			90	% rH
Protection class as per DIN EN 60529	IP67			
Operation				
<ul style="list-style-type: none"> <li>Ambient temperature (T6)</li> <li>Ambient temperature (T5)</li> </ul>	-40		+40	°C
	-40		+50	°C
Storage				

Environmental conditions	min.	typ.	max.	unit
<ul style="list-style-type: none"><li>Ambient temperature</li></ul>	-40		+70	°C

\*: Nominal value: please note that nominal values are also subject to tolerances. For more detailed information, see: ▶ *Note on nominal values [p.33]*

## 3.10.51 Max-100-Y, Max-100-Y-CTM

Mechanical properties	min.	typ.	max.	unit
Motor torque*		100		Nm
Motor runtime for 90° (can be configured with rotary switch)*		40 60 90 120 150		s
Minimum angle of rotation*		-5		°
Maximum angle of rotation*		90		°
Weight* <ul style="list-style-type: none"> <li>• Max-100-Y</li> <li>• Max-100-Y-CTM</li> </ul>		8 8		kg kg

Dimensions	min.	typ.	max.	unit
Max-100-Y				
L	-1	288	+1	mm
W	-1	149	+1	mm
H	-1	116	+1	mm
Max-100-Y-CTM				
L	-1	288	+1	mm
W	-1	149	+1	mm
H	-1	116	+1	mm
Hollow shaft double square	16 × 16			mm
Allen key provided for manual adjustment in accordance with these instructions*		4		mm

Electrical characteristics	min.	typ.	max.	unit
Minimum nominal voltage (at room temperature)	-10 %	24	+10 %	VAC/DC
Maximum nominal voltage (at room temperature)	-10 %	240	+10 %	VAC/DC
Minimum mains frequency	-20 %	50	+20 %	Hz
Maximum mains frequency	-20 %	60	+20 %	Hz
Nominal current (at room temperature)	▶ Nominal current [p.31]			
Power consumption standby*		5		W
Power consumption heating mode*		16		W
Power consumption in operation	▶ Nominal current [p.31]			

Electrical characteristics	min.	typ.	max.	unit
Switch-on peak				
<ul style="list-style-type: none"> <li>at 24 VDC (for approx. 2 seconds)*</li> <li>at 240 VDC (for approx. 2 seconds)*</li> </ul>		2		A
Maximum duty cycle for motor run time*				
40 s, 60 s, 90 s, 120 s, 150 s		100		%

Electrical connection options	
▶ 3-point with spring return constant spring return period continuous [p.24]	Cable type 5+PE, cable diameter 7.5 mm / cable type 6, cable diameter 7.4 mm
▶ 1-wire with spring return with constant spring return period continuous [p.25]	Cable type 4+PE, cable diameter 7.2 mm / cable type 6, cable diameter 7.4 mm

Activation CONTROL	min.	typ.	max.	unit
Angle of rotation and position indicator		95		°
Precision electrical*		~100		Step
Activation Y	0		10	VDC
	4		20	mA
Performance data Y and U				
<ul style="list-style-type: none"> <li>Activation <math>Y_U</math> (for 10 k<math>\Omega</math> output impedance)</li> <li>Activation <math>Y_I</math> (for 100 <math>\Omega</math> load / output impedance)</li> <li>Feedback <math>U_U</math> (for 10 k<math>\Omega</math>...<math>\infty</math> <math>\Omega</math> input impedance)</li> <li>Feedback <math>U_I</math> (for 0...800 <math>\Omega</math> load / input impedance)</li> </ul>	0		10	VDC
	4		20	mA
	0		10	VDC
	4		20	mA
Inverting	Setting up wire bridges between terminals 3 and 4			

Environmental conditions	min.	typ.	max.	unit
Humidity (not condensing)			90	% rH
Protection class as per DIN EN 60529	IP67			
Operation				
<ul style="list-style-type: none"> <li>Ambient temperature (T6)</li> <li>Ambient temperature (T5)</li> </ul>	-40		+40	°C
	-40		+50	°C
Storage				
<ul style="list-style-type: none"> <li>Ambient temperature</li> </ul>	-40		+70	°C

\*: Nominal value: please note that nominal values are also subject to tolerances. For more detailed information, see: ▶ *Note on nominal values [p.33]*



## 3.10.52 Max-150, Max-150-CTM, Max-150-VAM

Mechanical properties	min.	typ.	max.	unit
Motor torque (can be configured with rotary switch)*		150		Nm
Motor runtime for 90° (can be configured with rotary switch)*		40 60 90 120		s
Minimum angle of rotation*		-5		°
Maximum angle of rotation*		90		°
Weight* <ul style="list-style-type: none"> <li>• Max-150</li> <li>• Max-150-CTM</li> <li>• Max-150-VAM</li> </ul>		8 8 15.9		kg kg kg

Dimensions	min.	typ.	max.	unit
Max-150				
Max-150-CTM	-1	288	+1	mm
Max-150-VAM	-1	149	+1	mm
L	-1	116	+1	mm
W				
H				
Hollow shaft double square	16 × 16			mm
Allen key provided for manual adjustment in accordance with these instructions*		4		mm

Electrical characteristics	min.	typ.	max.	unit
Minimum nominal voltage (at room temperature)	-10 %	24	+10 %	VAC/DC
Maximum nominal voltage (at room temperature)	-10 %	240	+10 %	VAC/DC
Minimum mains frequency	-20 %	50	+20 %	Hz
Maximum mains frequency	-20 %	60	+20 %	Hz
Nominal current (at room temperature)	▶ <i>Nominal current [p.31]</i>			
Power consumption standby*		5		W
Power consumption heating mode*		16		W
Power consumption in operation	▶ <i>Nominal current [p.31]</i>			

## 3 | Device description

Electrical characteristics	min.	typ.	max.	unit
Switch-on peak				
<ul style="list-style-type: none"> <li>at 24 VDC (for approx. 2 seconds)*</li> <li>at 240 VDC (for approx. 2 seconds)*</li> </ul>		2		A
		2		A
Maximum duty cycle for motor run time*				
40 s, 60 s, 90 s, 120 s	100			%

**Electrical connection options**

▶ 3-point no spring return [p.20]	Cable type 4+PE, cable diameter 7.2 mm
-----------------------------------	--

Environmental conditions	min.	typ.	max.	unit
Humidity (not condensing)			90	% rH
Protection class as per DIN EN 60529	IP67			
Operation				
<ul style="list-style-type: none"> <li>Ambient temperature (T6)</li> <li>Ambient temperature (T5)</li> </ul>	-40		+40	°C
	-40		+50	°C
Storage				
<ul style="list-style-type: none"> <li>Ambient temperature</li> </ul>	-40		+70	°C

\*: Nominal value: please note that nominal values are also subject to tolerances. For more detailed information, see: ▶ *Note on nominal values [p.33]*

## 3.10.53 Max-150-S, Max-150-S-CTM, Max-150-S-VAM

Mechanical properties	min.	typ.	max.	unit
Motor torque*		150		Nm
Motor runtime for 90° (can be configured with rotary switch)*		40 60 90 120		s
Minimum angle of rotation*		-5		°
Maximum angle of rotation*		90		°
Weight* <ul style="list-style-type: none"> <li>• Max-150-S</li> <li>• Max-150-S-CTM</li> <li>• Max-150-S-VAM</li> </ul>		8 8 15.9		kg kg kg

Dimensions	min.	typ.	max.	unit
Max-150-S				
L	-1	288	+1	mm
W	-1	149	+1	mm
H	-1	116	+1	mm
Max-150-S-CTM				
L	-1	288	+1	mm
W	-1	149	+1	mm
H	-1	116	+1	mm
Max-150-S-VAM				
L	-1	289	+1	mm
W	-1	150	+1	mm
H	-1	116	+1	mm
Hollow shaft double square	16 × 16			mm
Allen key provided for manual adjustment in accordance with these instructions*		4		mm

Electrical characteristics	min.	typ.	max.	unit
Minimum nominal voltage (at room temperature)	-10 %	24	+10 %	VAC/DC
Maximum nominal voltage (at room temperature)	-10 %	240	+10 %	VAC/DC
Minimum mains frequency	-20 %	50	+20 %	Hz
Maximum mains frequency	-20 %	60	+20 %	Hz
Nominal current (at room temperature)	▶ <i>Nominal current [p.31]</i>			

## 3 | Device description

Electrical characteristics	min.	typ.	max.	unit
Power consumption standby*		5		W
Power consumption heating mode*		16		W
Power consumption in operation	▶ <i>Nominal current [p.31]</i>			
Switch-on peak				
<ul style="list-style-type: none"> <li>at 24 VDC (for approx. 2 seconds)*</li> <li>at 240 VDC (for approx. 2 seconds)*</li> </ul>		2		A
		2		A
Maximum duty cycle for motor run time*				
40 s, 60 s, 90 s, 120 s		100		%

Electrical connection options	
▶ <i>3-point no spring return [p.20]</i>	Cable type 4+PE, cable diameter 7.2 mm
▶ <i>Integrated limit switch [p.23]</i>	Cable type 6, cable diameter 7.4 mm

Electrical characteristics limit switch	min.	typ.	max.	unit
Switch point CLOSED	-2	5	+2	°
Switch point OPENED	-2	85	+2	°
Signal operation				
<ul style="list-style-type: none"> <li><math>U_{max}</math> DC*</li> <li><math>I_{max}</math> DC*</li> <li><math>I_{min}</math> AC/DC*</li> </ul>		48		V
		1		A
		5		mA
Power operation				
<ul style="list-style-type: none"> <li><math>U_{max}</math> AC*</li> <li><math>U_{min}</math> AC/DC*</li> <li><math>I_{max}</math> AC*</li> </ul>		250		V
		5		V
		5		A
After one-off operation with $U > 24$ VAC/DC or $I > 100$ mA:				
<ul style="list-style-type: none"> <li><math>U_{min}</math> AC/DC*</li> <li><math>I_{min}</math> AC/DC*</li> </ul>		12		V
		100		mA

Environmental conditions	min.	typ.	max.	unit
Humidity (not condensing)			90	% rH
Protection class as per DIN EN 60529	IP67			
Operation				

Environmental conditions	min.	typ.	max.	unit
<ul style="list-style-type: none"><li>Ambient temperature (T6)</li></ul>	-40		+40	°C
<ul style="list-style-type: none"><li>Ambient temperature (T5)</li></ul>	-40		+50	°C
Storage				
<ul style="list-style-type: none"><li>Ambient temperature</li></ul>	-40		+70	°C

\*: Nominal value: please note that nominal values are also subject to tolerances. For more detailed information, see: ▶ *Note on nominal values [p.33]*

### 3.11 Accessories

Name	Explanation
Ex/Red/InSwitch	External, upgradeable and locally adjustable auxiliary switch with two potential-free switch contacts, for retrofitting on ... max rotary drives
Ex/Red/InBox-3P	Terminal box suitable for ... max rotary drives with 1 cable, for OPEN-CLOSED or 3-point mode
Ex/Red/In-3P/SW	Terminal box suitable for ... max rotary drives with 1 cable, for OPEN-CLOSED or 3-point mode + 2 cables for external auxiliary switches Ex/Red/InSwitch
Ex/Red/In-Y/S	Terminal box suitable for ... max rotary drives with 2 cables, for continuous or 3-point mode + integrated limit switches
Ex/Red/InBox-Y/S/SW	Terminal box suitable for ... max rotary drives with 2 cables, for continuous or 3-point mode with feedback + 2 cables for external auxiliary switches Ex/Red/InSwitch
Ex/Red/InBox-BF	Terminal box suitable for ... max rotary drives with 1 cable, for all Ex/Red/In-BF
Ex/Red/InBox-BF/SW	Terminal box suitable for ... max rotary drives with 1 cable, for all Ex/Red/In-BF + 2 cables for external auxiliary switches Ex/Red/InSwitch
MKK-S, MKK-M	Installation bracket for ... terminal boxes for direct installation on size S or M rotary drives
KB-S	Clamping device for round damper shaft, diameter 10 mm to 20 mm, and square damper shaft, 10 mm to 16 mm, incl. rotation lock, suitable for ... size S box rotary drives
KB-A	Clamping device for round damper shaft diameter 1/2 ", suitable for "North America"-... size S box rotary drives
HV-SKU	Manual adjustment with locking mechanism, suitable for size S, short design
HV-SLU	Manual adjustment with locking mechanism, suitable for size S, long design for adding ... box or ... switch
HV-MU	Manual adjustment with locking mechanism, suitable for size M
AR-12-xx	Square insert to reduce axle intake from 12 mm × 12 mm to 11 mm, 10 mm, 9 mm or 8 mm (size S)
AR-16-xx	Square insert to reduce axle intake from 16 mm × 16 mm to 14 mm or 12 mm (size M)
Ex/InPro-TT-...	Safety temperature limiter for fire dampers, triggered at 71 °C / 72 °C, with 1 m unconnected cable end, only suitable for ...Box-BF drives (Ex-Max, RedMax and InMax models)
EXC-DS1/VA	Safety temperature limiter for duct installation, potential-free contact, switches at 70 °C...160 °C (in 10° steps)

Name	Explanation
DWB-S, DWB-M	90° angle of rotation limiter for installation on ... size S or M max rotary drives (details on request)
Retrofit-Kit-S	Mechanical adaptation for installation on ... size S max rotary drives; required if replacing a previous model EXT15...-F1, EXT12...-F16, EXT15... or EXT30....
Retrofit-Kit-M	Mechanical adaptation for installation on ... size M max rotary drives; required if replacing a previous model EXT30...-F3, EXT50...-F3, or EXT50....
ADS, ADM	Various adaptations are available for different fittings (details on request).
WS-S, WS-M	Stainless steel weather protection, suitable for all ... size S, M max rotary drives

## 4 Transportation and storage

### 4.1 Transportation

Check the delivery to ensure it is complete and intact. If you identify any transportation damage or if the delivery is not complete, please inform your distributor.

### 4.2 Packaging

All the packaging materials used are environmentally friendly. Packaging materials are valuable commodities and can be recycled. Please make sure the packaging materials are recycled. If this is not possible, packaging materials should be disposed of in accordance with local guidelines.

### 4.3 Storage

Store the product

- in the original packaging
- not outdoors
- and in a dry, frost-free, dust-free location
- that is protected from aggressive substances and direct sunlight

## 5 Installation and commissioning

---

**⚠ DANGER****Electric shock and risk of explosion**

If the actuator has not been connected to the protective conductor system (PE), there is a risk of electric shocks caused by a live housing in a fault condition. If the actuator is not connected to the equipotential bonding (PA), there is a risk of electric shocks and explosion caused by static charging of the housing.

1. Before starting up the actuator, make sure that it is correctly connected to the protective conductor system (PE) and the equipotential bonding (PA).
  2. Take measurements to verify the connection to the to the protective conductor system (PE) and to the equipotential bonding (PA).
- 

**⚠ DANGER****Risk of explosion**

In explosive atmospheres, human error can result in an explosion.

1. Make sure the type of actuator used meets your requirements for the explosion-protected area. You can find this information on the actuator label.  
Ex...: ATEX Zone 1, 2, 21, 22;  
Red...: ATEX Zone 2, 22;  
In...: not suitable for the explosion-protected area!
  2. As far as possible, avoid working in an explosive atmosphere.
  3. Disconnect the actuator from the power supply before carrying out any work on it in an explosive atmosphere.
  4. Make sure that installation and connection work is only carried out by appropriately trained skilled personnel.
  5. Always work adapted to the ambient conditions.
  6. Work in active potentially explosive atmospheres must be approved by the operating company.
-



**⚠ DANGER****Risk of death due to electric shock and short circuit**

Damage to the cabling or incorrect installation can result in an electric shock or short circuit and fire/explosion.

1. Make sure the electrical connection and integration of the control unit are only carried out by appropriately trained specialist personnel.
  2. Please ensure the cables are laid without being damaged. Bear in mind external influences on the cables and use appropriate cable ducts or cable trays.
  3. Make sure the wiring is done correctly (see circuit diagrams).
  4. Before commissioning/starting up, make sure all cables and the drive are undamaged.
  5. Remember the five electrical safety rules:
    - Unlock
    - Prevent it being switched back on
    - Ensure no voltage at all
    - Earth and short-circuit
    - Cover or block off adjacent parts that are still live.
- 

**⚠ CAUTION****Possible damage to musculoskeletal system**

Working in positions with an adverse body posture can result in orthopaedic injuries.

1. Make sure you are working as ergonomically as possible.
  2. Use appropriate tools, e.g. steps for easy access.
  3. Wear personal protective equipment: headgear and gloves.
-

**⚠ CAUTION****Impact and tripping hazard**

If the drive is not positioned carefully, it can pose an impact and tripping hazard.

1. As far as possible, avoid installing the drive in the area of footpaths or work areas.
2. Position the drive so that it does not cause any risk of tripping or head impact.
3. If necessary, provide warning indicators or padding around any potential impact points.

**⚠ WARNING****Risk of crushing and impact**

If the actuator starts up unexpectedly, crushing injuries can occur at the connected assemblies.

1. Potential crushing points should be considered in the integrator's risk assessment.
2. Check whether additional protective measures are necessary.
3. Before beginning work on the actuator, make sure it is completely disconnected from the power supply to prevent an unexpected start-up.
4. Make sure the actuator is assembled correctly.
5. Check that the actuator fits on the fitting.

**⚠ WARNING****Danger due to incorrectly integrated drives**

1. Hazards caused by the drive must be taken into account in your risk assessment for the complete machine. Bear in mind any crushing points associated with your installation setting.
2. Only use the drive as intended in accordance with these installation instructions.
3. Make sure that the drive meets your requirements:  
ambient conditions such as temperature, atmosphere, protection against corrosion;  
drive torque;  
necessary travel speeds/runtimes;  
reset function;

activation;  
achievable reliability in implementing safety functions;  
logic of the safety function: safe status in the event of a drop in voltage via reset mechanism.

**⚠ DANGER****Risk to life and risk of property damage due to incorrect electrical connection**

If inputs 1 to 5 of the multi-turn actuator are connected to different supply voltages, there is a risk of electric shocks and of serious damage to the multi-turn actuator.

1. Connect inputs 1 to 5 of the multi-turn actuator to a uniform supply voltage.
2. Note the bridges between the inputs drawn on the connection diagrams.

**⚠ WARNING****Risk of crushing and impact**

In the event of a power outage, the rotary drives with spring-return mechanism will return suddenly to their initial position. This can result in crushing or impact injuries if work is being carried out on the rotary drive and its connected assemblies at this time.

1. Disconnect the power to the rotary drive before starting work. Make sure that nobody is working on the rotary drive or the connected assemblies (e.g. ventilation flaps) at this time.
2. Only carry out work when the rotary drive spring is not under tension and is in its initial position.

**⚠ WARNING****Risk of crushing and impact**

If the Allen key is inserted, this can result in crushing and impact injuries in the event of unexpected start-up of the drive.

1. Before starting work, disconnect the drive from the power supply to prevent an unexpected start-up.
2. Remove the Allen key immediately after use.

**⚠ WARNING****Risk of impact**

If the drive falls while work is being carried out, it can hit and injure someone.

1. During installation and when dismantling, make sure nobody is located below you.
2. During the installation, make sure that the drive cannot loosen or detach itself. The same applies over longer periods, taking into account external influences such as vibration, corrosion etc.

**⚠ WARNING****Finger twisting**

At the open end of the shaft, there can be unexpected rotational movements, e.g. if the rotary drive is accidentally switched on or if the return spring is triggered by a power outage.

1. Never stick your fingers into the open end of the shaft.
2. Only operate the rotary drive once it is installed.
3. Turn off the power to the rotary drive before starting work to avoid it being started unexpectedly.

Comply with any applicable national and international standards and regulations for Ex areas. Certified equipment must be installed in accordance with the manufacturer's instructions. If you use the device in a manner that contravenes that stipulated by the manufacturer, this can impair the safety level of the device. For project planning, selecting and installing electrical systems, EN/IEC 60079-14 can be consulted. An Ex e terminal box (e.g. Ex-Box-...) must be used for the electrical connection.

- Lay the connection cables securely and so they are adequately protected against physical or thermal damage.
- Put in place a potential equalisation mechanism.
- Avoid temperature transfer from the fitting to the drive unit.

## Dimensions

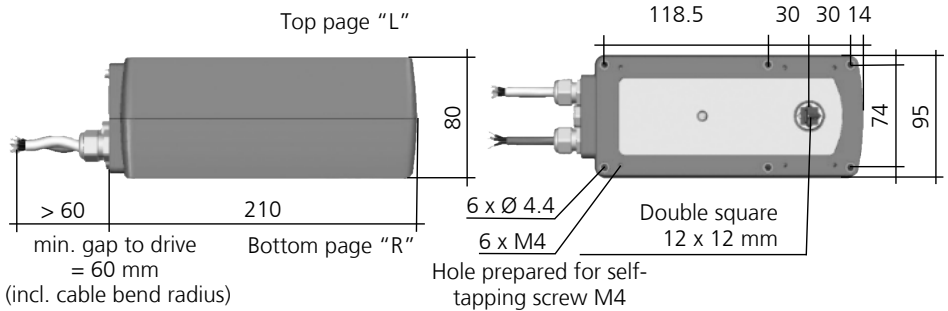

## Dimensions

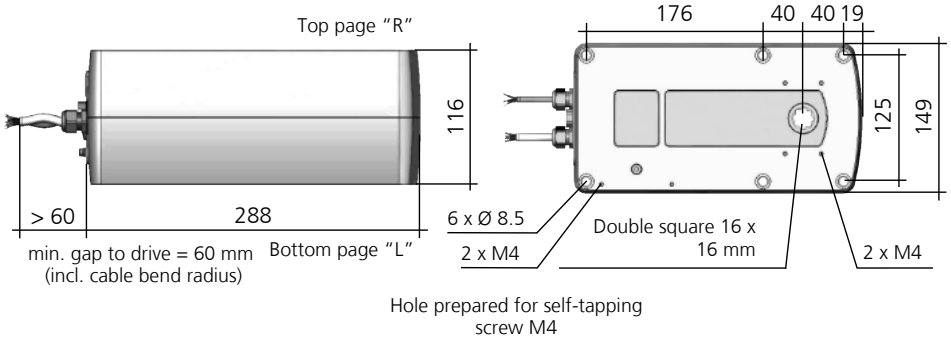

## 5.1 Axle connection

### Interlocking axle connection

By default, the rotary drives are equipped with an interlocking axle connection. In other words, the rotary drive is slotted directly onto the damper shaft. The interlocking axle connection offers the most secure way to link the damper shaft and the drive as it avoids any slipping in comparison with a friction-locked connection.

### Friction-locked axle connection

A friction-locked axle connection is always required if a round damper shaft is being used. In this case, the accessory KB-S (clamping device and rotation lock) is required. Friction-locked axle connections are only used for size S rotary drives.

## 5.2 Preparing for installation

Four M4 screws are included in the delivery for mounting the rotary drives.

The drives are constructed so they are axially symmetrical. In case of a spring-return function, the safety position must be selected on site by turning the drive through 180°. It is also important to remember that the drives have a total positioning angle of approx. 95° in order to pre-tension the actuator (air damper or similar). Pre-tensioning is only appropriate if the rotary drive should close the actuator. In this case, the 5° ensures the actuator is closed with "outlet pressure".

Pre-tensioning must be calibrated mechanically via the manual adjustment "HV" before the rotary drive is mounted on the drive axle. The hexagonal Allen key must be turned anticlockwise if looking from the "R side" of the rotary drive, or clockwise if looking from the "L side". The symbol next to the "HV" socket shows the direction of rotation.

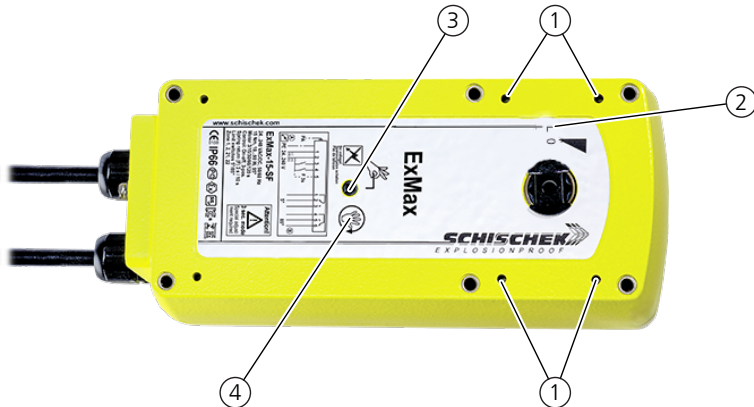

Fig. 25: Explanations for installation

1	Position for mounting screws	2	Symbol for "L side" or "R side"
3	"HV" socket	4	Shows direction of rotation for the hexagonal Allen key

### Determine installation position for the rotary drive and prepare device

1. Determine whether the rotary drive should close or open your air damper or valve.
2. Check the direction of rotation for the drive axle on your device, which will be the means of reaching the final position. Use a spanner for this if applicable.
  - ⇒ This will enable you to determine the position in which the rotary drive needs to be installed. The picture above shows the correct installation position if the drive axle needs to be turned to the left to reach the desired final position.
3. Make sure your device is in the desired final position (open or closed).

## 5.3 Parameter setting

For parameter setting, all rotary drives are equipped with a 10-position switch, a button and a 3-colour LED.

These controls are located on the cable side behind the two small, central blanking plugs or pressure-compensation elements (carefully twist in and out). The blanking plugs need to be removed to operate.

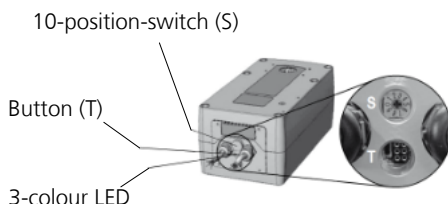

Operation / parameter setting can be undertaken despite pending voltage applied to the rotary drive. Afterwards, the removed blanking plugs must be inserted again to ensure the drive does not lose its IP protection class.

The switch and button are operated using a screwdriver. Never apply force by vigorously pressing and/or twisting as this can cause irreparable damage to the control electronics.

The torque and runtime can also be configured prior to installation. Adjustment of the angle of rotation can only be begun when there is a power supply and the device has been correctly installed.

### Rotary switch settings size S

Size S type 5.10 or 15.30 (for types -S, -SF, -BF)			
Torque (motor):		5 Nm / 15 Nm	10 Nm / 30 Nm
desired motor run time:	3 s	00	05
	15 s	01	06
	30 s	02	07
	60 s	03	08
	120 s	04	09

Remaining size S types (for types -F1, -SF1 and -BF1)			
Torque (motor):		8 Nm / 15 Nm	
desired motor run time:	3 s	00	
	15 s	01	
	30 s	02	

**Remaining size S types (for types -F1, -SF1 and -BF1)**

Torque (motor):		8 Nm / 15 Nm	
	60 s	03	
	120 s	04	

**Size S type 5.10 or 15.30 (for types -Y, -YF, -CY and -CYF)**

Torque (motor):		5 Nm / 15 Nm	10 Nm / 30 Nm
desired motor run time:	7.5 s	00	05
	15 s	01	06
	30 s	02	07
	60 s	03	08
	120 s	04	09

Switch position **02** is the factory setting.

**Example**

ExMax-15.30



**Desired parameters:**

Torque 30 Nm

Motor run time 30 s/90°

**Result:**

Switch position 07

**Rotary switch settings size M**

<b>Type 50.75 for size M</b>			
<b>Torque (motor):</b>		<b>50 Nm</b>	<b>75 Nm</b>
desired motor run time:	40 s	00	05
	60 s	01	06
	90 s	02	<u>07</u>
	120 s	03	08
	150 s	04	09

<b>Types for size M (-150, -150-S, -60, -60-F, -60-BF, -60-SF)</b>		
<b>Torque (motor):</b>		<b>30 Nm / 50 Nm / 60 Nm / 100 Nm / 150 Nm</b>
desired motor run time:	40 s	00
	60 s	01
	90 s	<b>02</b>
	120 s	03
	150 s	04

<b>Types for size M (-100, -100-S, -30, -30-F, -50, -50-F, -50-BF, -50-SF)</b>		
<b>Torque (motor):</b>		<b>30 Nm / 50 Nm / 60 Nm / 100 Nm / 150 Nm</b>
desired motor run time:	40 s	00
	60 s	01
	90 s	<b>02</b>
	120 s	03
	150 s	04

Switch position **02** is the factory setting.

**Example**

ExMax-50.75

**Desired parameters:**

Torque 75 Nm

Motor run time 90 s/90°

**Result:**Switch position 07

## 5.4 Installation on air dampers (interlocking axle connection)

**NOTICE****Serious damage to property due to interruption of the power supply**

Irreparable damage to the drive occurs if the power supply is interrupted during the adjustment run.

- Leave the drive connected to the power supply without interruption during the adjustment run.

1. Install the four M4 threaded holes for mounting the rotary drive on the damper or on an on-site mounting bracket.
2. Insert the Allen key into the "HV" socket and turn it approx. 1 1/2 rotations in the direction of the arrow until the mounting holes on the drive align with those on the damper (symbol on the right of the "HV" socket).

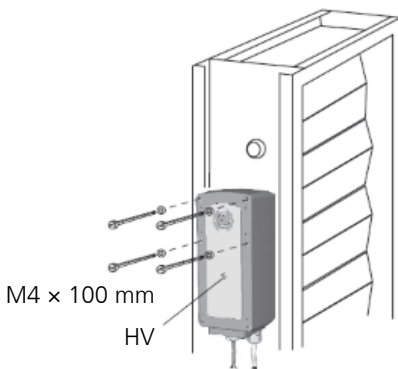

3. Hold the Allen key in position to maintain this alignment.

4. Put the rotary drive on the damper shaft and secure it diagonally with 2 mounting screws.
5. Remove the Allen key.
6. Screw in the remaining mounting screws and tighten all the mounting screws securely.
7. Check the functionality via manual operation with a small angle of max. 2 revolutions of the HV (Allen key in "HV" socket).

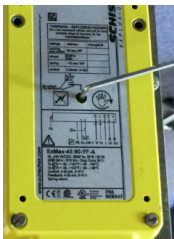

8. Connect the rotary drive to the power supply with just the terminals 1-2.
  - ⇒ The LED on the rotary drive turns green.
9. Turn the switch (S) to position 02 (small torque) or 07 (large torque). Keep the button (T) pressed for at least 3 seconds.
  - ⇒ The drive moves independently to both end positions and detects the blocking positions (adjusting run). The LED flashes green during the adjustment. The adjustment lasts approx. 60 s for size S and 180 s for size M.

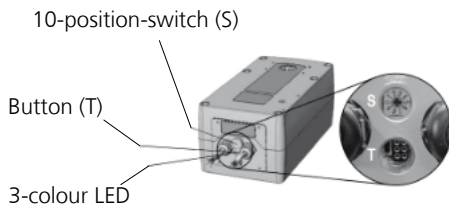

- ⇒ The rotary drive moves slowly through the complete turning range in both directions to establish its precise end positions (adjustment run).
10. Connect all the remaining terminals and turn the switch (S) to the required position.
    - ⇒ The selected parameters will be executed during the next regulation/setting function.
- ⇒ The rotary drive has now been correctly installed.

## 5.5 Installation on air dampers (friction-locked axle connection)

To install a friction-locked axle connection (divergent damper shafts on the device) the accessory KB-S (► *Accessories [p. 170]*) is required. The same applies for spring pre-tensioning as for the interlocking axle connection.

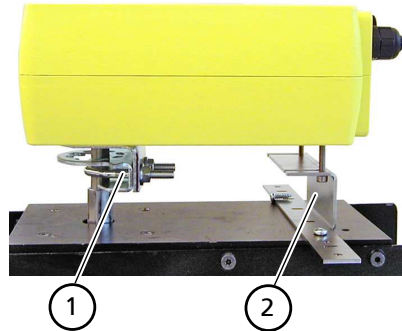

1	Clamping device	2	Rotation lock
---	-----------------	---	---------------

1. Insert the clamping device into the rotary drive and screw it from the opposite side using the Allen key.

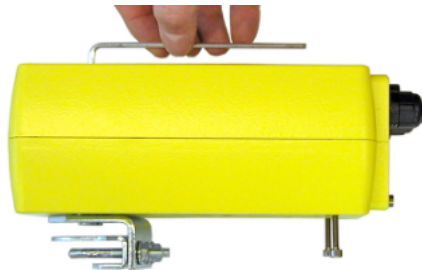

2. Twist two screws into the drive unit as a rotation lock limit so that they can still move in the slot for the rotation lock.
3. Fix the rotation lock to the device.

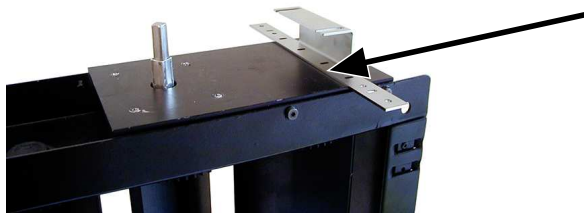

4. Mount the drive on the drive shaft. Position and mount it in the rotation lock so that it can gently swing to compensate for the non-central connection. For this reason, the screws should not be firmly tightened. Gentle movements in the slots must be possible.

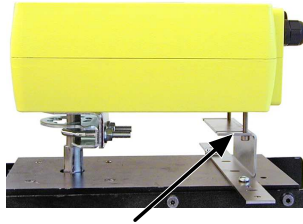

5. Tighten the clamping device with the spanner.  
⇒ The rotary drive has now been correctly installed.

## 5.6 Installation on fire dampers

Installation of a rotary drive on a fire damper is done in the same way as the installation on an air damper.

Having said that, it is important to note that a temperature trigger ... Pro-TT ... should generally be connected here too!

## 5.7 Installation on ball cocks and throttle valves

Special adaptations are required for installation on ball cocks and throttle valves.

1. Screw the actuator with 4 screws into the relevant adapted device (e.g. ball cock).

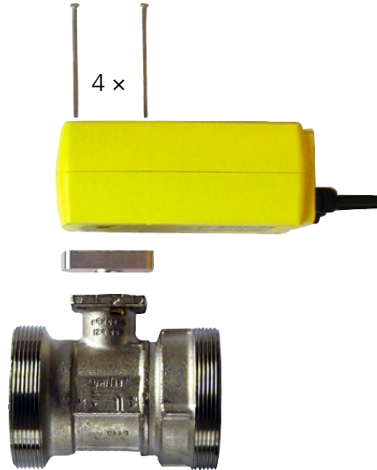

Note that when some ball cocks are closed, a small opening can occur again at 95°. If this should be the case in your device and this is not desired, we recommend the DWB accessory.

## 5.8 Installation of terminal boxes ... box on drive by means of installation bracket MKK-S (accessory)

1. Screw the MKK-S installation bracket with 4 screws to the rotary drive on the cable side.



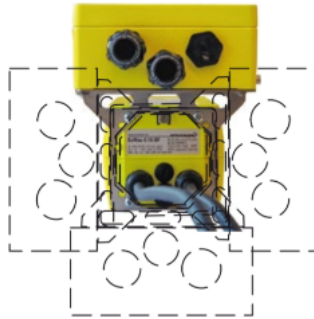

⇒ Depending on the bracket installation, there are eight different possible positions for the terminal box (looking from the cable side, four positions in a clockwise direction, each rotated through 90°, terminal box above the drive unit or terminal box in front of the drive unit).

2. Screw the terminal box to the bracket.



## 5.9 Installation of auxiliary switch ... switch on the drive unit

The auxiliary switch can only be installed with a square connection. The switch always comes with a square connection for Max-S and Max-M.

1. Insert the appropriate connection into the rotary drive. Caution: Lug fitting into the slot for the square.

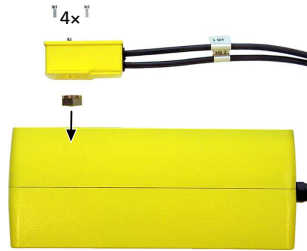

2. Insert the auxiliary switch ... switch up and screw it with the four screws.

## 5.10 Installation outside

Make sure that the drive units are protected by a weatherproof cover against direct sunlight (heat and UV) and against rain and snow ▶ *Accessories [p.170]*.

Apply the supply voltage immediately after installation to get the integrated heating system ready for operation.

Since these drives have an internal thermal cutoff, they should not be exposed to high temperatures either during storage or when operational. Otherwise the safety device may be triggered and permanently deactivate the drive unit.



## 6 Operation

---



### **DANGER**

#### **Electric shock and risk of explosion**

If the actuator has not been connected to the protective conductor system (PE), there is a risk of electric shocks caused by a live housing in a fault condition. If the actuator is not connected to the equipotential bonding (PA), there is a risk of electric shocks and explosion caused by static charging of the housing.

1. Before starting up the actuator, make sure that it is correctly connected to the protective conductor system (PE) and the equipotential bonding (PA).
  2. Take measurements to verify the connection to the protective conductor system (PE) and to the equipotential bonding (PA).
- 



### **DANGER**

#### **Risk of explosion**

In explosive atmospheres, human error can result in an explosion.

1. Make sure the type of actuator used meets your requirements for the explosion-protected area. You can find this information on the actuator label.  
Ex...: ATEX Zone 1, 2, 21, 22;  
Red...: ATEX Zone 2, 22;  
In...: not suitable for the explosion-protected area!
  2. As far as possible, avoid working in an explosive atmosphere.
  3. Disconnect the actuator from the power supply before carrying out any work on it in an explosive atmosphere.
  4. Make sure that installation and connection work is only carried out by appropriately trained skilled personnel.
  5. Always work adapted to the ambient conditions.
  6. Work in active potentially explosive atmospheres must be approved by the operating company.
-

**⚠ DANGER****Risk of death due to electric shock and short circuit**

Damage to the cabling or incorrect installation can result in an electric shock or short circuit and fire/explosion.

1. Make sure the electrical connection and integration of the control unit are only carried out by appropriately trained specialist personnel.
2. Please ensure the cables are laid without being damaged. Bear in mind external influences on the cables and use appropriate cable ducts or cable trays.
3. Make sure the wiring is done correctly (see circuit diagrams).
4. Before commissioning/starting up, make sure all cables and the drive are undamaged.
5. Remember the five electrical safety rules:  
Unlock  
Prevent it being switched back on  
Ensure no voltage at all  
Earth and short-circuit  
Cover or block off adjacent parts that are still live.

**⚠ WARNING****Risk of crushing and impact**

If the actuator starts up unexpectedly, crushing injuries can occur at the connected assemblies.

1. Potential crushing points should be considered in the integrator's risk assessment.
2. Check whether additional protective measures are necessary.
3. Before beginning work on the actuator, make sure it is completely disconnected from the power supply to prevent an unexpected start-up.
4. Make sure the actuator is assembled correctly.
5. Check that the actuator fits on the fitting.

**⚠ WARNING****Risk of crushing and impact**

In the event of a power outage, the rotary drives with spring-return mechanism will return suddenly to their initial position. This can result in crushing or impact injuries if work is being carried out on the rotary drive and its connected assemblies at this time.

1. Disconnect the power to the rotary drive before starting work. Make sure that nobody is working on the rotary drive or the connected assemblies (e.g. ventilation flaps) at this time.
2. Only carry out work when the rotary drive spring is not under tension and is in its initial position.

**⚠ WARNING****Risk of crushing and impact**

If the Allen key is inserted, this can result in crushing and impact injuries in the event of unexpected start-up of the drive.

1. Before starting work, disconnect the drive from the power supply to prevent an unexpected start-up.
2. Remove the Allen key immediately after use.

**⚠ WARNING****Risk of impact**

If the drive falls while work is being carried out, it can hit and injure someone.

1. During installation and when dismantling, make sure nobody is located below you.
2. During the installation, make sure that the drive cannot loosen or detach itself. The same applies over longer periods, taking into account external influences such as vibration, corrosion etc.

**⚠ WARNING****Finger twisting**

At the open end of the shaft, there can be unexpected rotational movements, e.g. if the rotary drive is accidentally switched on or if the return spring is triggered by a power outage.

1. Never stick your fingers into the open end of the shaft.
2. Only operate the rotary drive once it is installed.
3. Turn off the power to the rotary drive before starting work to avoid it being started unexpectedly.

**⚠ CAUTION****Possible damage to musculoskeletal system**

Working in positions with an adverse body posture can result in orthopaedic injuries.

1. Make sure you are working as ergonomically as possible.
2. Use appropriate tools, e.g. steps for easy access.
3. Wear personal protective equipment: headgear and gloves.

**⚠ CAUTION****Impact and tripping hazard**

If the drive is not positioned carefully, it can pose an impact and tripping hazard.

1. As far as possible, avoid installing the drive in the area of footpaths or work areas.
2. Position the drive so that it does not cause any risk of tripping or head impact.
3. If necessary, provide warning indicators or padding around any potential impact points.

## 6.1 Operating modes

### 6.1.1 Manual operation

Before any manual adjustment, the power to the rotary drive must be off. The adjustment is made using the Allen key provided.

### 6.1.2 Operation with 3-second motor run time

When operating with a 3-second motor run time, the following should be noted:

1. The 3-s mode is only possible for switch positions 00 and 05, and only for a constant voltage for at least 1 minute at terminals 1 and 2.
2. Depending on the installation position, the rotary drive opens (or closes) with voltage at terminal 3, and closes (or opens) with voltage at terminal 4.
3. The maximum duty cycle is one actuation/standard cycle per minute. Between two 3-s operations in the same direction, there must be a pause of at least 1 minute. If an adjustment in the same direction is attempted in less than the prescribed time, the function will be blocked until the idle period has elapsed but will be enabled again automatically afterwards.
4. The same is true with regard to the spring-mode for spring-return drives, which constitutes a drive function in direction I.
5. If an attempt is made to operate a spring-return drive in switch positions 00 or 05 with 1-wire control, the motor run time will automatically switch to 15 s / 90° to avoid an uncontrolled duty cycle and thus potential overheating of the rotary drive.

### 6.1.3 3-point standard operation

To protect elements such as gears and connecting elements against harmful effects due to control pulses that are too short ... Max rotary drives are protected through the internal electronics. The electronic system ignores impulses < 0.5 s. The control signal must be present for min. 0.5 s. For a directional change, the pause is 1 s.

#### Additional information for activation in 3-point operation

The direction of rotation for the motor depends on the positions of contacts a and b:

- contact a closed, contact b open = direction I
- contact a and b closed = motor does not turn
- contact b closed, contact a open = direction II
- contact a and b open = motor does not turn.

Example:

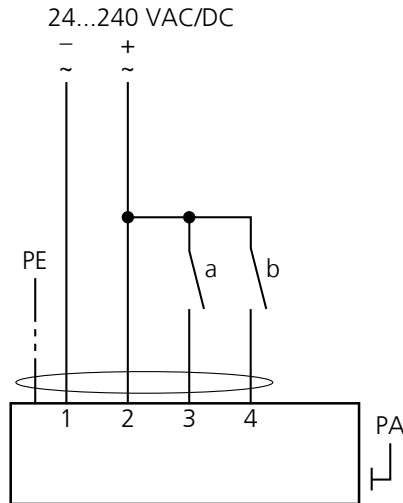

The direction of rotation (I and II) depends on the left/right installation of the rotary drive on the device. A motorised change to the direction of rotation is done by swapping the connecting wires 3 and 4.

### 6.1.4 Spring-return function

The spring-return function is only activated if the supply network for terminals 1 or 2 is interrupted. In the event of an interruption, thanks to the spring the rotary drive always moves to its final position, even if the power supply is restored during the reset function. Afterwards the actuation and standard function is continued.

### 6.1.5 Use at ambient temperatures below -20 °C

The rotary drives are equipped with integrated, regulated heating for use at ambient temperature down to -40 °C. The heating is supplied automatically when there is a constant voltage supply to terminals 1 and 2.

1. Once the rotary drive is installed, it must be connected to the electrical system immediately.
2. The heating switches on automatically if the rotary drive reaches an internal temperature of -20 °C. It warms the rotary drive up to operating temperature then switches off automatically. The rotary drive will not move during this heating up phase.
3. Actuation and standard function are only ensured after this heating up period.

### 6.1.6 Excessive temperatures

Based on the ATEX Ex regulations, rotary drives must be protected against excessive temperatures with respect to the temperature class. This is done via an internal thermostat, which acts as a maximum threshold limiter and, if a fault occurs, will permanently turn off the rotary drive in the event of inadmissible temperatures. An upstream temperature sensor ensures the rotary drive is switched off before this point in the event of an operating error. This safety function is reversible, so the drive is operational again once it has cooled down. However, the fault must be remedied on-site immediately!

### 6.1.7 Synchronous operation

It is not permitted to have multiple rotary drives on one axle connection or mechanically connected rotary drives.

### 6.1.8 Mechanical protection (only F1/F3 types)

The rotary drives must be operated with a minimal external load.

Type	Minimal load torque [Nm]
ExMax-8-F1 (CTS, VAS), ExMax-8-SF1 (CTS, VAS), ExMax-8-BF1 (CTS, VAS)	2
ExMax-15-F1 (CTS, VAS), ExMax-15-SF1 (CTS, VAS), ExMax-15-BF1 (CTS, VAS)	5
ExMax-30-BF3 (CTM), ExMax-30-F3 (CTM, VAM), ExMax-30-SF3 (CTM, VAM)	8
ExMax-50-BF3 (CTM, VAM), ExMax-50-F3 (CTM), ExMax-50-SF3 (CTM, VAM)	15

### 6.1.9 Power outage

In the event of a power outage, first the spring return is operated. When the mains supply is restored, a new reference run will be triggered automatically. This means, the rotary drive goes to the CLOSED position then, depending on activation, the rotary drive goes to the OPEN position.

## 7 Maintenance

---



### **DANGER**

#### **Risk of explosion**

In explosive atmospheres, human error can result in an explosion.

1. Make sure the type of actuator used meets your requirements for the explosion-protected area. You can find this information on the actuator label.  
Ex...: ATEX Zone 1, 2, 21, 22;  
Red...: ATEX Zone 2, 22;  
In...: not suitable for the explosion-protected area!
  2. As far as possible, avoid working in an explosive atmosphere.
  3. Disconnect the actuator from the power supply before carrying out any work on it in an explosive atmosphere.
  4. Make sure that installation and connection work is only carried out by appropriately trained skilled personnel.
  5. Always work adapted to the ambient conditions.
  6. Work in active potentially explosive atmospheres must be approved by the operating company.
- 



### **WARNING**

#### **Risk of crushing and impact**

In the event of a power outage, the rotary drives with spring-return mechanism will return suddenly to their initial position. This can result in crushing or impact injuries if work is being carried out on the rotary drive and its connected assemblies at this time.

1. Disconnect the power to the rotary drive before starting work. Make sure that nobody is working on the rotary drive or the connected assemblies (e.g. ventilation flaps) at this time.
  2. Only carry out work when the rotary drive spring is not under tension and is in its initial position.
-



**⚠ WARNING****Risk of impact**

If the drive falls while work is being carried out, it can hit and injure someone.

1. During installation and when dismantling, make sure nobody is located below you.
2. During the installation, make sure that the drive cannot loosen or detach itself. The same applies over longer periods, taking into account external influences such as vibration, corrosion etc.

**⚠ CAUTION****Impact and tripping hazard**

If the drive is not positioned carefully, it can pose an impact and tripping hazard.

1. As far as possible, avoid installing the drive in the area of footpaths or work areas.
2. Position the drive so that it does not cause any risk of tripping or head impact.
3. If necessary, provide warning indicators or padding around any potential impact points.

The actuators do not need maintenance in terms of function. Relevant regional maintenance regulations must be complied with in accordance with legal requirements or factory standards.

Drive units are maintenance-free. An annual inspection is recommended. The applicable standards can be consulted for inspecting and servicing electrical systems. Ex devices should only be opened by the manufacturer.

All applicable national and international standards and regulations for Ex areas must be observed. Certified equipment must be installed in accordance with the manufacturer's instructions. If you use the device in a manner that contravenes that stipulated by the manufacturer, this can impair the safety level of the device. The applicable standards can be consulted for project planning, selection and setting up electrical systems. An Ex e terminal box (e.g. ExBox-...) must be used for the electrical connection. ▶ *Accessories [p.170]*.

**Routine inspections of fire dampers**

For periodic inspections, it is important to make sure this takes place with the voltage disconnected (cut off the power supply to the drive). The test button on the ExPro-TT- ... is only for on-site checks on the drive function.

## 8 Troubleshooting



### **DANGER**

#### **Risk of explosion**

In explosive atmospheres, human error can result in an explosion.

1. Make sure the type of actuator used meets your requirements for the explosion-protected area. You can find this information on the actuator label.  
Ex...: ATEX Zone 1, 2, 21, 22;  
Red...: ATEX Zone 2, 22;  
In...: not suitable for the explosion-protected area!
2. As far as possible, avoid working in an explosive atmosphere.
3. Disconnect the actuator from the power supply before carrying out any work on it in an explosive atmosphere.
4. Make sure that installation and connection work is only carried out by appropriately trained skilled personnel.
5. Always work adapted to the ambient conditions.
6. Work in active potentially explosive atmospheres must be approved by the operating company.



### **DANGER**

#### **Risk of death due to electric shock and short circuit**

Damage to the cabling or incorrect installation can result in an electric shock or short circuit and fire/explosion.

1. Make sure the electrical connection and integration of the control unit are only carried out by appropriately trained specialist personnel.
2. Please ensure the cables are laid without being damaged. Bear in mind external influences on the cables and use appropriate cable ducts or cable trays.
3. Make sure the wiring is done correctly (see circuit diagrams).
4. Before commissioning/starting up, make sure all cables and the drive are undamaged.
5. Remember the five electrical safety rules:  
Unlock  
Prevent it being switched back on

Ensure no voltage at all  
Earth and short-circuit  
Cover or block off adjacent parts that are still live.

**⚠ WARNING****Risk of crushing and impact**

In the event of a power outage, the rotary drives with spring-return mechanism will return suddenly to their initial position. This can result in crushing or impact injuries if work is being carried out on the rotary drive and its connected assemblies at this time.

1. Disconnect the power to the rotary drive before starting work. Make sure that nobody is working on the rotary drive or the connected assemblies (e.g. ventilation flaps) at this time.
2. Only carry out work when the rotary drive spring is not under tension and is in its initial position.

**⚠ WARNING****Risk of crushing and impact**

If the Allen key is inserted, this can result in crushing and impact injuries in the event of unexpected start-up of the drive.

1. Before starting work, disconnect the drive from the power supply to prevent an unexpected start-up.
2. Remove the Allen key immediately after use.

**⚠ WARNING****Risk of crushing and impact**

If the actuator starts up unexpectedly, crushing injuries can occur at the connected assemblies.

1. Potential crushing points should be considered in the integrator's risk assessment.
2. Check whether additional protective measures are necessary.
3. Before beginning work on the actuator, make sure it is completely disconnected from the power supply to prevent an unexpected start-up.
4. Make sure the actuator is assembled correctly.
5. Check that the actuator fits on the fitting.

**⚠ WARNING****Risk of impact**

If the drive falls while work is being carried out, it can hit and injure someone.

1. During installation and when dismantling, make sure nobody is located below you.
2. During the installation, make sure that the drive cannot loosen or detach itself. The same applies over longer periods, taking into account external influences such as vibration, corrosion etc.

**⚠ WARNING****Finger twisting**

At the open end of the shaft, there can be unexpected rotational movements, e.g. if the rotary drive is accidentally switched on or if the return spring is triggered by a power outage.

1. Never stick your fingers into the open end of the shaft.
2. Only operate the rotary drive once it is installed.
3. Turn off the power to the rotary drive before starting work to avoid it being started unexpectedly.

**⚠ CAUTION****Possible damage to musculoskeletal system**

Working in positions with an adverse body posture can result in orthopaedic injuries.

1. Make sure you are working as ergonomically as possible.
2. Use appropriate tools, e.g. steps for easy access.
3. Wear personal protective equipment: headgear and gloves.



## ⚠ CAUTION

### Impact and tripping hazard

If the drive is not positioned carefully, it can pose an impact and tripping hazard.

1. As far as possible, avoid installing the drive in the area of footpaths or work areas.
2. Position the drive so that it does not cause any risk of tripping or head impact.
3. If necessary, provide warning indicators or padding around any potential impact points.

Problem	Possible causes	Resolution strategy
Drive does not work, LED not lit up	There is no power supply	Connect the power supply and switch it on
	The actuator is operated at an ambient temperature outside the specifications and the internal thermal cutoff has been irreversibly triggered	Impermissible operation has resulted in the actuator being put into an irreversible state for safety reasons, and the actuator must be replaced. For the new installation, the ambient temperature must be reduced at the same time
Drive does not work, LED is red	The actuator is operated at an ambient temperature that is too high, resulting in the internal temperature sensor being triggered	Switch off the actuator and allow it to cool down, take appropriate steps to lower the ambient temperature, e.g. by ventilation or a different mounting position
	To function, ...-BF drives need a temperature trigger of type ...Pro-TT or FireSafe	Connect the trigger, LED turns green, drive is ready for operation
Drive does not work, LED is green	3-point control signal connected to both inputs	Correct the circuit
	The required torque is greater than the torque supplied by the drive	Configure a higher torque on the drive, if this is available, or replace the drive with a type offering a higher torque
	Control signals do not fit or are on the wrong wire	Check the control and actuator signals and connect as per circuit diagram

Problem	Possible causes	Resolution strategy
	The actuator has been installed incorrectly and is blocked by an external stop	Uninstall the drive, check that it works without any load, then install it in such a way that power can be transmitted from the drive to the fitting/valve that needs to be moved without any external impediment or torsion
	Power supply connected to the wrong poles	Cables reversed: 1 must be connected to (-, N) and 2 to (+, L)
Actuator is not running, LED is flashing red	The actuator was installed at temperatures < -20 °C and has not yet reached its operating temperature of at least -20 °C	Ensure there is a constant power supply to wire 1–2
		Wait until the necessary operating temperature has been reached by the actuator's internal heating. The actuator then starts to work independently
Y-drive cannot start intermediate positions in 3-point mode	The switch from continuous mode to 3-point mode has not been made	Set the drive parameters in accordance with the installation instructions
Drive is in a skewed position on the square damper shaft	The drives have an angle of rotation of 95° incl. 5° pre-tensioning. The pre-tensioning was not taken into account during installation	Remove the drive from the damper shaft, use the Allen key to manually raise it by approx. 5° before placing it on the damper shaft for attachment. Follow the installation instructions!
A Y-continuous drive which works with a restricted angle of rotation reaches its end positions already at > 0 V / 4 mA or < 10 V/20 mA	No adjustment of the angle of rotation was made during commissioning	Adjust the angle of rotation in accordance with the installation instructions
LED flashes irregularly, actuator is not running	Actuator is not receiving sufficient supply voltage	Increase the wire cross-section or the voltage at the transformer/ power supply output
	Wiring too long, excessive drop in voltage in the supply cable	Increase the wire cross-section or the voltage
<b>Only for size S:</b>		
Spring-return function is 10 s/ 90°, but should be 3 s/ 90°	Bridge 2–5 missing	Bridge wire 2 for the constant voltage supply with wire 5
Spring-return function is 3 s/ 90°, but should be 10 s/ 90°	Bridge 2–5 installed	Remove bridge

Problem	Possible causes	Resolution strategy
Drive will not start up after more than 2 brief sequential setting functions in 3-s mode	The maximum permissible duty cycle of 1 minute break after 3 sec. motor runtime was not adhered to, the drive is in safety shutdown mode	Wait roughly 1 minute for the internal electronics to cool down to operating temperature again
Drive has been installed with clamping device KB-S so it is friction-locked on the damper shaft and is only partly functioning or not at all	Assuming the aforementioned basic electrical conditions have been met, it is possible the rotation lock has been installed such that the drive is tensioned and impeding itself due to the non-central axle connection	Loosen the rotation lock and install it so that the drive can execute a slight oscillation around its angle of rotation

The following figure shows the possible flashing sequences of the multi-coloured LEDs, the table shows the meaning of the sequences. In the figure, each square is equal to an interval of 100 ms.

Prio	1	2	3	4	5	6	7	8	9	10
0										
1	r	r	r	r	r	r	r	r	r	
2	r	r	y	y	r	r	y	y		
3	r		r		r		r		r	
4	r	r	r	r	y	y	y	y		
5	g	y	g	y	g	g	g	g	g	
6	y	g	y	g	y	y	y	y	y	
7	g	y	g	g	g	g	g	g	g	
8	y	g	y	y	y	y	y	y	y	
9	g		g		g		g		g	
10	y		y		y		y		y	
11	g	g	g	g	g	g	g	g	g	
12	y	y	y	y	y	y	y	y	y	

0	Drive is idle
1	Internal error – notify service.
2	Internal error – notify service.
3	Internal error – notify service.
4	Fire protection is active, contact BF is open
5	Blockage at top
6	3-point execution with Y feedback: Blockage at top
7	Blockage at bottom
8	3-point execution with Y feedback: Blockage at bottom
9	Adjustment run
10	3-point execution with Y feedback: Adjustment run
11	OK
12	3-point execution with Y-feedback: OK



## 9 Uninstalling, decommissioning, disposal

### Decommissioning

The spring must be loosened completely before the drive is uninstalled. For rotary drives with spring-return function, the spring pre-tensioning must be eliminated before the four mounting screws are finally removed. Only then can the rotary drive be easily removed from the drive shaft.

1. Insert the Allen key into the rotary drive's HV socket and turn it approx. 1 1/2 revolutions in the direction of rotation.  
⇒ This cancels out the spring pre-tensioning, the drive sits loosely on the drive shaft.
2. Remove all four mounting screws and take the rotary drive off the drive shaft.



#### **DANGER**

##### **Danger to life through touching live parts**

Inside the drive, there are live parts that carry a high electrical voltage that is extremely dangerous.

1. Do not open the cover of the terminal box if it is live.
2. Before starting to dismantle the drive, completely disconnect it from the power supply.



#### **NOTICE**

- When decommissioning, please note the Ex protection regulations.

### Disposal

Recycle any dismantled/defective components:

- Scrap any metal components.
- Take all plastic components to be recycled.
- Sort all other components by material and dispose of these in accordance with local specifications.

**NOTICE****Environmental risk through incorrect disposal**

Incorrect disposal can result in environmental risks.

1. Always use approved specialist companies for the disposal of electronic waste, lubricants and other auxiliary materials.
  2. In case of any doubt, consult your local authority or a specialist disposal company regarding environmentally friendly disposal options.
  3. When disposing of equipment and auxiliary materials (e.g. oils, fats), please also refer to the relevant manufacturer's information, in particular the safety data sheet.
-

## 10 EU declaration of incorporation as set out in the EC Machinery Directive 2006/42/EC, Annex II B Rotary Drives ExMax, RedMax, InMax

We,

Schischek GmbH  
Mühlsteig 45  
Gewerbegebiet Süd 5  
90579 Langenzenn  
GERMANY,

declare under our sole responsibility in accordance with the provisions in the guidelines:

### Rotary Drives ExMax, RedMax, InMax

Satisfies the following health and safety requirements set out in Annex I of the Machinery Directive 2006/42/EC:

Annex 1.5.6 Fire  
Annex I, 1.1.2 Principles of safety integration  
Annex I, 1.1.3 Materials and products  
Annex I, 1.1.6 Ergonomics  
Annex I, 1.3.3 Risks due to falling or ejected objects  
Annex I, 1.3.7 Risks related to moving parts  
Annex I, 1.5.1 Electricity supply  
Annex I, 1.5.10 Radiation  
Annex I, 1.5.7 Explosion  
Annex I, 1.6.1 Machinery maintenance  
Annex I, 1.7.2 Warning of residual risks  
Annex I, 1.7.3 Marking of machinery  
Annex I, 1.7.4 Instructions

Harmonised standards applied:

EN ISO 12100:2010

The partly completed machinery must only be operated if it has been established, where appropriate, that the machinery in which the partly completed machinery is to be incorporated satisfies the provisions in the Machinery Directive 2006/42/EC.

The specific documents under Annex VII part B pertaining to the partly completed machinery have been created. The manufacturer undertakes to submit the specific documents for the partly completed machinery to the competent authority in digital or printed form.



## EU-Einbauerklärung im Sinne der EG-Maschinenrichtlinie 2006/42/EG, Anhang II B Drehantriebe ExMax, RedMax, InMax

Der Hersteller
<b>Schischek GmbH</b> Mühlsteig 45 Gewerbegebiet Süd 5 90579 Langenzenn GERMANY
erklärt hiermit, dass die unvollständige Maschine
<b>Drehantriebe ExMax, RedMax, InMax</b>
den folgenden grundlegenden Sicherheits- und Gesundheitsschutzanforderungen nach Anhang I der Maschinenrichtlinie 2006/42/EG entspricht:
<b>Anhang I, 1.1.2 Grundsätze für die Integration der Sicherheit</b> <b>Anhang I, 1.1.3 Materialien und Produkte</b> <b>Anhang I, 1.1.6 Ergonomie</b> <b>Anhang I, 1.3.3 Risiken durch herabfallende oder herausgeschleuderte Gegenstände</b> <b>Anhang I, 1.3.7 Risiken durch bewegliche Teile</b> <b>Anhang I, 1.5.1 Elektrische Energieversorgung</b> <b>Anhang I, 1.5.10 Strahlung</b> <b>Anhang I, 1.5.6 Brand</b> <b>Anhang I, 1.5.7 Explosion</b> <b>Anhang I, 1.6.1 Wartung der Maschine</b> <b>Anhang I, 1.7.2 Warnung vor Restrisiken</b> <b>Anhang I, 1.7.3 Kennzeichnung der Maschinen</b> <b>Anhang I, 1.7.4 Betriebsanleitung</b>
Angewandte harmonisierte Normen:
<b>EN ISO 12100:2010</b>
Die unvollständige Maschine darf erst in Betrieb genommen werden, wenn gegebenenfalls festgestellt wurde, dass die Maschine, in die die unvollständige Maschine eingebaut werden soll, den Bestimmungen der Maschinenrichtlinie 2006/42/EG entspricht. Die zur unvollständigen Maschine gehörenden speziellen Unterlagen nach Anhang VII Teil B wurden erstellt. Der Hersteller verpflichtet sich, die speziellen Unterlagen zur unvollständigen Maschine der zuständigen Behörde gegebenenfalls in digitaler oder gedruckter Form zu übermitteln.
Bevollmächtigter für das Zusammenstellen der technischen Unterlagen:
 (Matthias Schäfer)
90579 Langenzenn, 2021-05-03

Fig. 26: Original

# 11 EU Declaration of Conformity ExMax-..., ExMax...CT...

We,
Schischek GmbH Mühlsteig 45 Gewerbegebiet Süd 5 90579 Langenzenn GERMANY,
declare under our sole responsibility in accordance with the provisions in the guidelines:

2014/30/EU  
2014/34/EU2014/35/EU  
RoHS 2011/65/EU

that the product
------------------

## ExMax-..., ExMax...CT...

covered by this declaration conforms to the following standards or normative documents:
---

EN 60079-0:2018	EN 61000-3-2:2006+A1:2009+A2:2009	EN 61000-4-6:1996+A1:2001
EN 60079-0	EN 61000-3-3:2013	EN 61000-6-2:2005
EN 60079-0	EN 61000-4-2:2009	EN 61000-6-4:2007
EN 60079-0	EN 61000-4-4:2012	EN 61010-1:2010
EN 60079-1:2014	EN 61000-4-4:2012	ISO 80079-36 :2016
EN 60079-11:2012	EN 61000-4-4:2012	ISO 80079-37
EN 60079-31:2014	EN 61000-4-5:2006	
EN 60529:1991+A1:2000+A2:2013	EN 61000-4-6:1996+A1:2001	

Marking:
----------



EPS 17 ATEX 1 132 X  
II 2 (2) D Ex tb [ib Db] IIIC T80°C, T95°C, T130°C Db  
II 2 (2) G Ex db [ib Gb] IIC T6, T5, T4 Gb

**ExMax-...-CT**  
EPS 17 ATEX 1 132 X  
II 2 (2) D Ex tb [ib Db] IIIC T80°C, T95°C, T130°C Db  
II 2 (2) G Ex db [ib Gb] IIB T6, T5, T4 Gb

**ExMax-...; ExMax-...-CT**  
Ex h IIC T6/T5/T4 Gb  
Ex h IIIC T80°C/T95°C/T130°C Db  
IECEX EPS 20.0027 X

Notified body and identification number:
--

Product approval: Bureau Veritas Consumer Products Services Germany GmbH, Wilhelm-Hennemann-Straße 8, 19061 Schwerin, Germany, NB 2004

Quality management system: DEKRA Testing and Certification GmbH, Dinnendahlstraße 9, 44809 Bochum



**EU-Konformitätserklärung ExMax-...; ExMax-...-CT**

Wir, die	
Schischek GmbH Mühlsteig 45 Gewerbegebiet Süd 5 90579 Langenzenn GERMANY	
erklären in alleiniger Verantwortung gemäß den Bestimmungen der Richtlinien:	
2014/30/EU 2014/34/EU	2014/35/EU RoHS 2011/65/EU
dass das Produkt	
<b>ExMax-...; ExMax-...-CT</b>	
auf das sich diese Erklärung bezieht, mit den folgenden Normen oder den normativen Dokumenten übereinstimmt:	
EN 55016-1-2:2014+A1:2018 EN 55016-2-1:2014+A1:2017 EN 55016-2-3:2017+A1:2019 EN 60079-0:2018/AC:2020-02 EN 60079-1:2014/AC:2018-09 EN 60079-11:2012 EN 60079-31:2014 EN 60529:1991+A1:2000+A2:2013	EN 61000-3-2:2019 EN 61000-3-3:2013+A1:2019 EN 61000-4-2:2009 EN 61000-4-4:2012 EN 61000-4-5:2014+A1:2017 EN 61000-4-6:2014 EN 61000-4-8:2010 EN 61000-6-2:2019
Kennzeichnung:	
<b>0158</b> EPS 17 ATEX 1 132 X II 2 (2) D Ex tb [ib Db] IIIC T80°C, T95°C, T130°C Db II 2 (2) G Ex db [ib Gb] IIC T6, T5, T4 Gb  <b>ExMax-...-CT</b> EPS 17 ATEX 1 132 X II 2 (2) D Ex tb [ib Db] IIIC T80°C, T95°C, T130°C Db II 2 (2) G Ex db [ib Gb] IIB T6, T5, T4 Gb  <b>ExMax-...; ExMax-...-CT</b> Ex h IIC T6/T5/T4 Gb Ex h IIIC T80°C/T95°C/T130°C Db IIECEx EPS 20.0027 X	
Benannte Stelle und Identifikationsnummer:	
Produktzulassung: Bureau Veritas Consumer Products Services Germany GmbH, Wilhelm-Hennemann-Straße 8, 19061 Schwerin, Germany, NB 2004 QM-System: DEKRA Testing and Certification GmbH, Dinnendahlstraße 9, 44809 Bochum	
Geschäftsführer:	
 (Matthias Schäfer)	
90579 Langenzenn, 2023-02-17	

Fig. 27: Original

## 12 EU Declaration of Conformity RedMax-...; RedMax-...-CT

We,

Schischek GmbH  
Mühlsteig 45  
Gewerbegebiet Süd 5  
90579 Langenzenn  
GERMANY,

declare under our sole responsibility in accordance with the provisions in the guidelines:

2014/30/EU  
2014/34/EU

2014/35/EU  
RoHS 2011/65/EU

that the product

### RedMax-...; RedMax-...-CT

covered by this declaration conforms to the following standards or normative documents:

EN 60079-0:2018	EN 61000-3-2:2006+A1:2009+A2:2009	EN 61000-4-6:1996+A1:2001
EN 60079-0	EN 61000-3-3:2013	EN 61000-6-2:2005
EN 60079-0	EN 61000-4-2:2009	EN 61000-6-4:2007
EN 60079-0	EN 61000-4-4:2012	EN 61010-1:2010
EN 60079-1:2014	EN 61000-4-4:2012	ISO 80079-36 :2016
EN 60079-11:2012	EN 61000-4-4:2012	ISO 80079-37
EN 60079-31:2014	EN 61000-4-5:2006	
EN 60529:1991+A1:2000+A2:2013	EN 61000-4-6:1996+A1:2001	

Marking:



EPS 18 ATEX 1 216 x  
II 3 (3) D Ex tc [ic Dc] IIIC T80°C, T95°C, T130°C Dc  
II 3 (3) G Ex db [ic Gc] IIC T6 / T5 / T4 Gc

**RedMax-...-CT**  
EPS 18 ATEX 1 216 x  
II 3 (3) D Ex tc [ic Dc] IIIC T80°C, T95°C, T130°C Dc  
II 3 (3) G Ex db [ic Gc] IIB T6 / T5 / T4 Gc

**RedMax-...; RedMax-...-CT**  
Ex h IIC T6/T5/T4 Gc  
Ex h IIIC T80°C/T95°C/T130°C Dc  
IECEX EPS 20.0027 X

Notified body and identification number:

Product approval: Bureau Veritas Consumer Products Services Germany GmbH, Wilhelm-Hennemann-Straße 8, 19061 Schwerin, Germany, NB 2004



**EU-Konformitätserklärung RedMax-...; RedMax-...-CT**



Wir, die	
Schischek GmbH Mühlsteig 45 Gewerbegebiet Süd 5 90579 Langenzenn GERMANY	
erklären in alleiniger Verantwortung gemäß den Bestimmungen der Richtlinien:	
2014/30/EU 2014/34/EU	2014/35/EU RoHS 2011/65/EU
dass das Produkt	
<b>RedMax-...; RedMax-...-CT</b>	
auf das sich diese Erklärung bezieht, mit den folgenden Normen oder den normativen Dokumenten übereinstimmt:	
EN 55016-1-2:2014+A1:2018 EN 55016-2-1:2014+A1:2017 EN 55016-2-3:2017+A1:2019 EN 60079-0:2018/AC:2020-02 EN 60079-1:2014/AC:2018-09 EN 60079-11:2012 EN 60079-31:2014 EN 60529:1991+A1:2000+A2:2013	EN 61000-3-2:2019 EN 61000-3-3:2013+A1:2019 EN 61000-4-2:2009 EN 61000-4-4:2012 EN 61000-4-5:2014+A1:2017 EN 61000-4-6:2014 EN 61000-4-8:2010 EN 61000-6-2:2019
	EN 61000-6-4:2019 EN 61010-1:2010+A1:2019+A1:2019/AC:2019 EN IEC 61000-4-11:2020+AC:2020 EN IEC 61000-4-3:2020 EN ISO 80079-36:2016 EN ISO 80079-37:2016
Kennzeichnung:	
 EPS 18 ATEX 1 216 x II 3 (3) D Ex tc [ic Dc] IIIC T80°C, T95°C, T130°C Dc II 3 (3) G Ex db [ic Gc] IIC T6 / T5 / T4 Gc  <b>RedMax-...-CT</b> EPS 18 ATEX 1 216 x II 3 (3) D Ex tc [ic Dc] IIIC T80°C, T95°C, T130°C Dc II 3 (3) G Ex db [ic Gc] IIB T6 / T5 / T4 Gc  <b>RedMax-...; RedMax-...-CT</b> Ex h IIC T6/T5/T4 Gc Ex h IIIC T80°C/T95°C/T130°C Dc IECEx EPS 20.0027 X	
Benannte Stelle und Identifikationsnummer:	
Produktzulassung: Bureau Veritas Consumer Products Services Germany GmbH, Wilhelm-Hennemann-Straße 8, 19061 Schwerin, Germany, NB 2004	
Geschäftsführer:	
 (Matthias Schäfer)	
90579 Langenzenn, 2023-02-17	

Fig. 28: Original



## 13 EU Declaration of Conformity InMax-...

We,
Schischek GmbH Mühlsteig 45 Gewerbegebiet Süd 5 90579 Langenzenn GERMANY,
declare under our sole responsibility in accordance with the provisions in the guidelines:

2014/30/EU  
2014/35/EU

RoHS 2011/65/EU

that the product
------------------

### InMax-...



covered by this declaration conforms to the following standards or normative documents:
---

EN 60079-0  
EN 60079-0  
EN 60079-0  
EN 60529:1991+A1:2000+A2:2013  
EN 61000-3-2:2006+A1:2009+A2:2009  
EN 61000-3-3:2013EN 61000-4-2:2009  
EN 61000-4-4:2012  
EN 61000-4-4:2012  
EN 61000-4-4:2012  
EN 61000-4-5:2006  
EN 61000-4-6:1996+A1:2001EN 61000-4-6:1996+A1:2001  
EN 61000-6-2:2005  
EN 61000-6-4:2007  
EN 61010-1:2010

Marking:
----------



**EU-Konformitätserklärung InMax-...**

Wir, die		
Schischek GmbH Mühlsteig 45 Gewerbegebiet Süd 5 90579 Langenzenn GERMANY		
erklären in alleiniger Verantwortung gemäß den Bestimmungen der Richtlinien:		
2014/30/EU 2014/35/EU	RoHS 2011/65/EU	
dass das Produkt		
InMax-...		
auf das sich diese Erklärung bezieht, mit den folgenden Normen oder den normativen Dokumenten übereinstimmt:		
EN 55016-1-2:2014+A1:2018 EN 55016-2-1:2014+A1:2017 EN 55016-2-3:2017+A1:2019 EN 60529:1991+A1:2000+A2:2013 EN 61000-3-2:2019 EN 61000-3-3:2013+A1:2019	EN 61000-4-2:2009 EN 61000-4-4:2012 EN 61000-4-5:2014+A1:2017 EN 61000-4-6:2014 EN 61000-4-8:2010 EN 61000-6-2:2019	EN 61000-6-4:2019 EN 61010-1:2010+A1:2019+A1:2019/ AC:2019 EN IEC 61000-4-11:2020+AC:2020 EN IEC 61000-4-3:2020
Kennzeichnung:		
		
Geschäftsführer:		
 (Matthias Schäfer)		
90579 Langenzenn, 2023-02-17		

**SCHISCHEK**

A **rotork** Brand

Keeping the World Flowing for  
Future Generations

---